

1. FOR USE WITH RG-214/U
2. BRAID CRIMP: USE MILITARY TOOL M22520/5-01, WITH DIE SET M22520/5-25, CAVITY A OR EQUIVALENT
3. CENTER CONTACT CRIMP: USE MILITARY TOOL M22520/5-01, WITH DIE SET M22520/5-25, CAVITY B OR EQUIVALENT

RECOMMENDED STRIP LENGTH
 SCALE 1:1

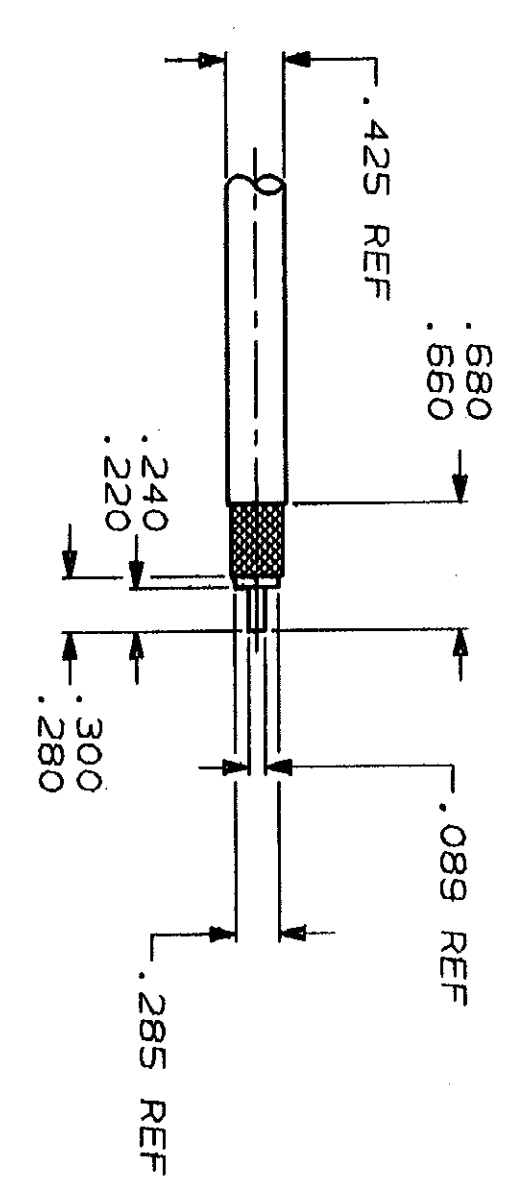

LOC	DIST	REV	ZONE	LTR	REVISIONS	DATE	APPD
DF	X0	P		0	RELEASED NPR 90-0064	3-5-90	PV

QTY	PART NO	DESCRIPTION	ITEM NO
1	447091-3	CONTACT, FEMALE	4
1	228143-4	HEAT SHRINK TUBING	3
1	447101-1	SOCKET ASSEMBLY	2
1	446556-9	FERRULE	1

DO NOT SCALE PRINT.
 UNLESS SPECIFIED
 DIMENSIONS IN INCHES
 TOLERANCES ON:
 1 PLC DEC ± .005
 2 PLC DEC ± .005
 3 PLC DEC ± .005
 ANGLES ±
 MATERIAL

DR P. YEAGER 2-13-90
 CHK J. CABARLO 2-26-90
 APPD R. HOSLER 2-28-90
 PRODUCT SPEC

AMP INCORPORATED
 AMP
 COAXIAL CONTACT,
 SOCKET, SIZE 1

FINISH	APPLICATION SPEC	WEIGHT	SIZE	FSCM NO	DRAWING NO
-	-	-	C	00779	447087-1
			SCALE	4:1	SHEET 1 OF 1

CUSTOMER DRAWING

单击下面可查看定价，库存，交付和生命周期等信息

[>>TE Connectivity\(泰科\)](#)