

LOC	DIST	REVISIONS					
GP	00	P	LTN	DESCRIPTION	DATE	DWN	APVD
		A		REVISED PER ECO-15-002647	05MAR2015	AP	MS
		B		REVISED PER ECO-16-014593	13FEB2017	JW	SH

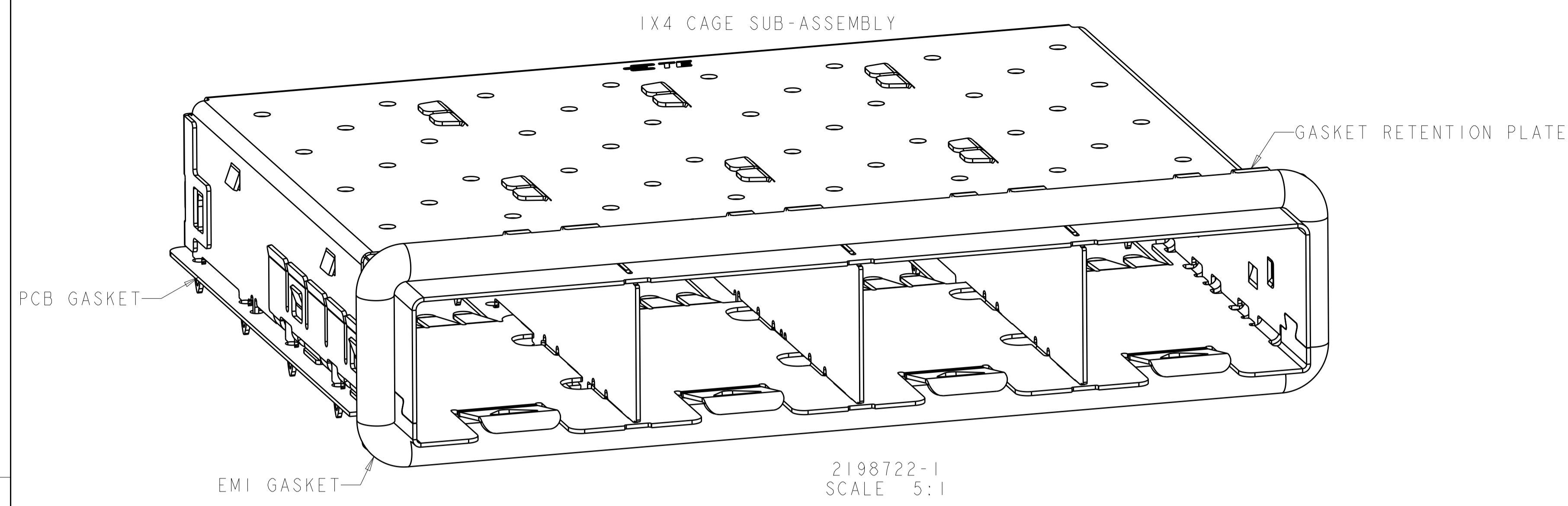

- MATERIAL:  
 CAGE ASSEMBLY: NICKEL SILVER ALLOY  
 GASKET RETENTION PLATE: STAINLESS STEEL  
 EMI GASKET: PLATED FILLED SILICONE  
 PCB GASKET: RF ABSORBER
- MINIMUM PC BOARD THICKNESS:  
 SINGLE SIDED = 1.45mm  
 BELLY TO BELLY = 3mm
- PADS AND VIAS CHASSIS GROUND
- DATUM AND BASIC DIMENSION ESTABLISHED BY CUSTOMER
- MATES WITH SFP MSA COMPLIANT TRANSCEIVERS
- INTERPRETATION OF DATUM REFERENCE FRAME IN ACCORDANCE WITH SECT 4.4.1.1 OF ASME Y14.5M-1994
- REFERENCE APPLICATION SPEC. 114-13120, HOLE A, FOR RECOMMENDED DRILL HOLE DIAMETER AND PLATING THICKNESS
- REFERENCE APPLICATION SPEC. 114-13120, HOLE B, FOR RECOMMENDED DRILL HOLE DIAMETER AND PLATING THICKNESS
- HOLE PATTERN REPEATS FOR EACH PORT, SPACING BETWEEN PORTS IS 14.25mm
- PRODUCT COMPLIES WITH SPECIFICATION SFF-8433, IMPROVED PLUGGABLE FORM FACTOR FOR SFP+ GANGED CAGES
- CONTACT STANDOFF WILL PIERCE GASKET WHEN PROPERLY PRESSED INTO PCB.

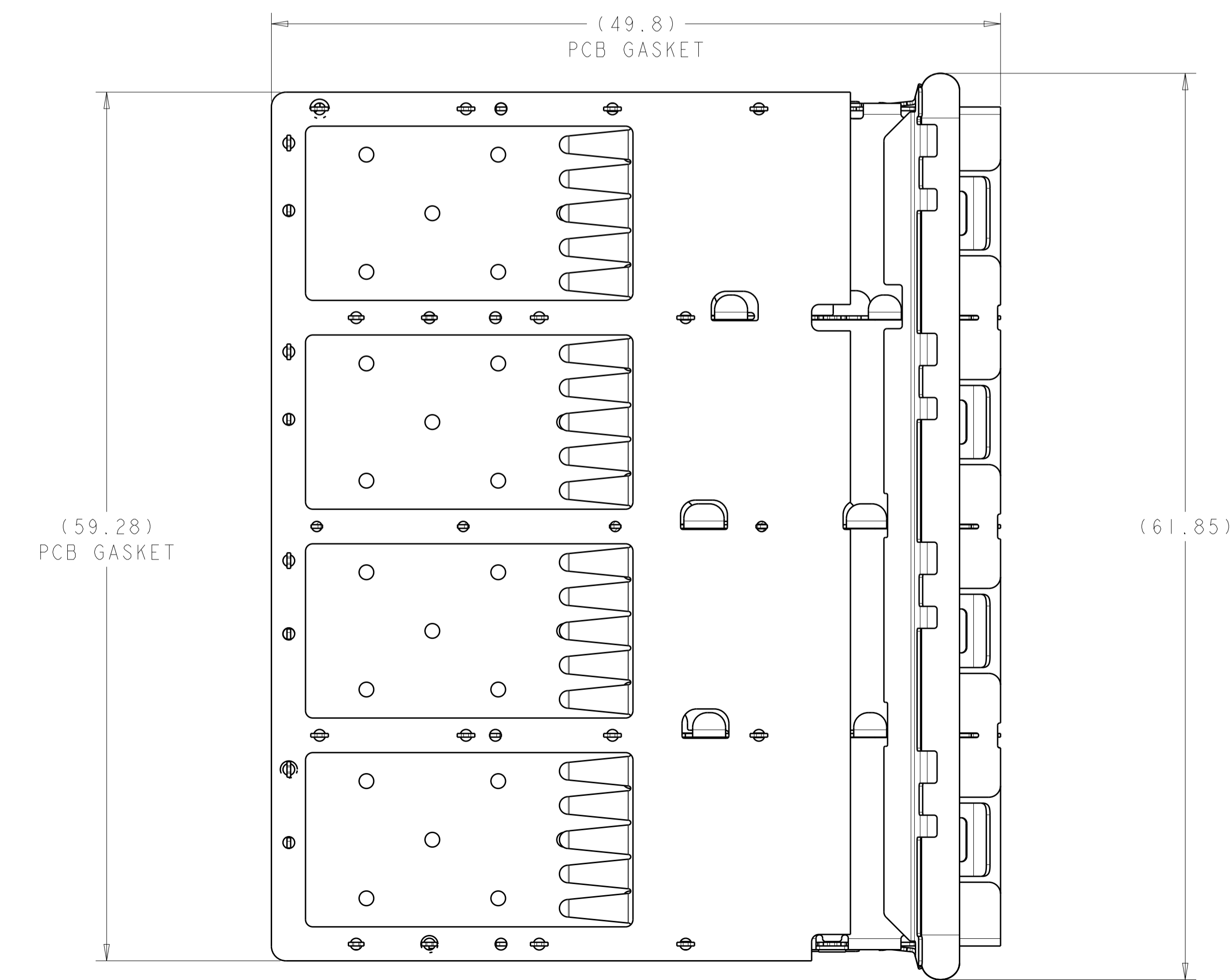
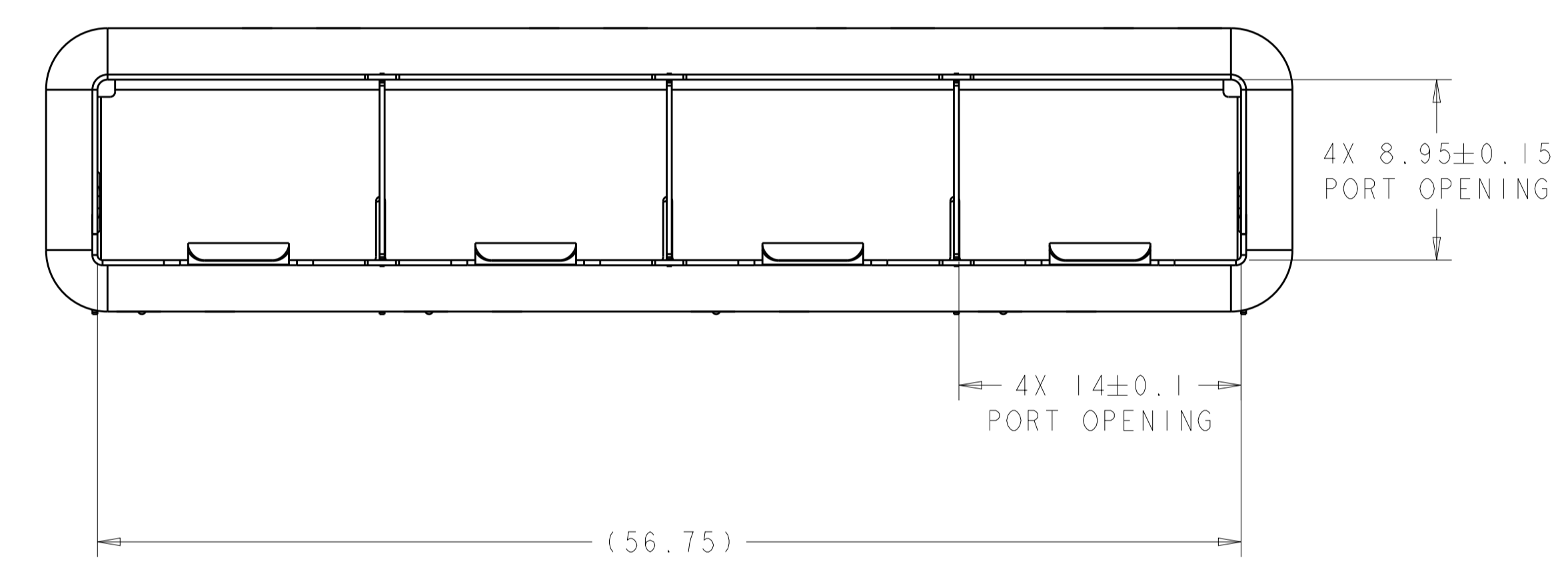
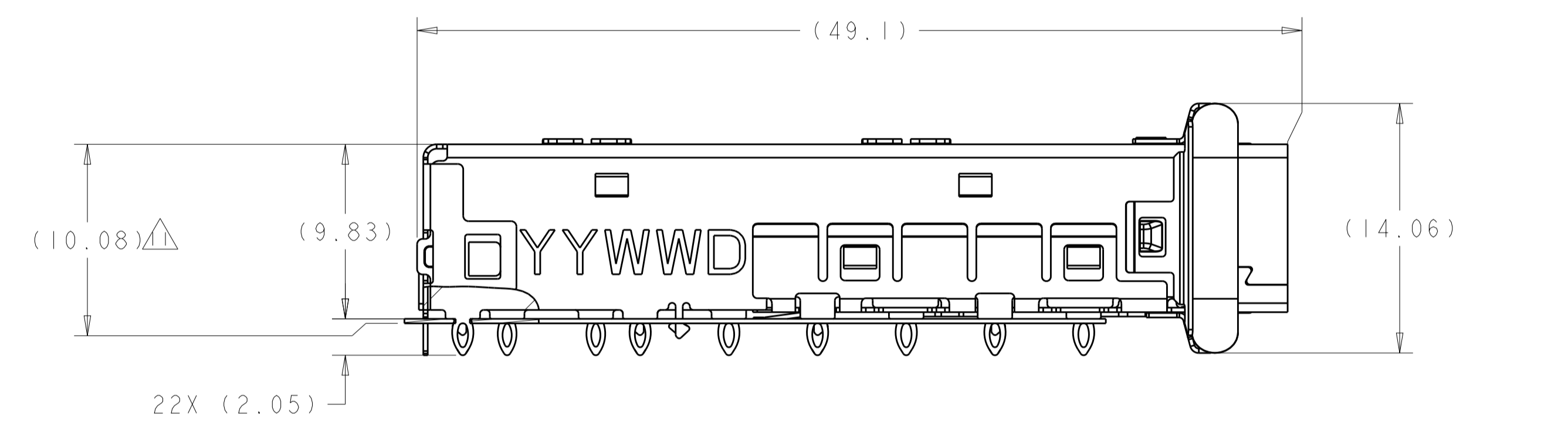

2198722-1  
PART NUMBER

THIS DRAWING IS A CONTROLLED DOCUMENT.		DWN: M.E. CONNER 27DEC2012	TE Connectivity	
DIMENSIONS: mm		CHK: M.D. MORRISON 01FEB2013		
TOLERANCES UNLESS OTHERWISE SPECIFIED:		APVD: M.J. PHILLIPS 01FEB2013	NAME: CAGE ASSEMBLY, ENHANCED, PRESS-FIT, 1X4, zSFP+	
0 PLC ±0.25		PRODUCT SPEC: 108-2364	SIZE: CAGE CODE DRAWING NO: A100779C=2198722	
1 PLC ±0.25		APPLICATION SPEC: 114-13120	RESTRICTED TO: -	
2 PLC ±0.25		WEIGHT: -	SCALE: 4:1 SHEET 1 OF 4 REV B	
3 PLC ±0.25		Customer Drawing		
4 PLC ±0.25				
ANGLES ±1°				
FINISH: -				
MATERIAL: SEE NOTE 1				

LOC	DIST	REVISIONS					
GP	00	P	LTN	DESCRIPTION	DATE	DMN	APVD
		-		SEE SHEET 1			

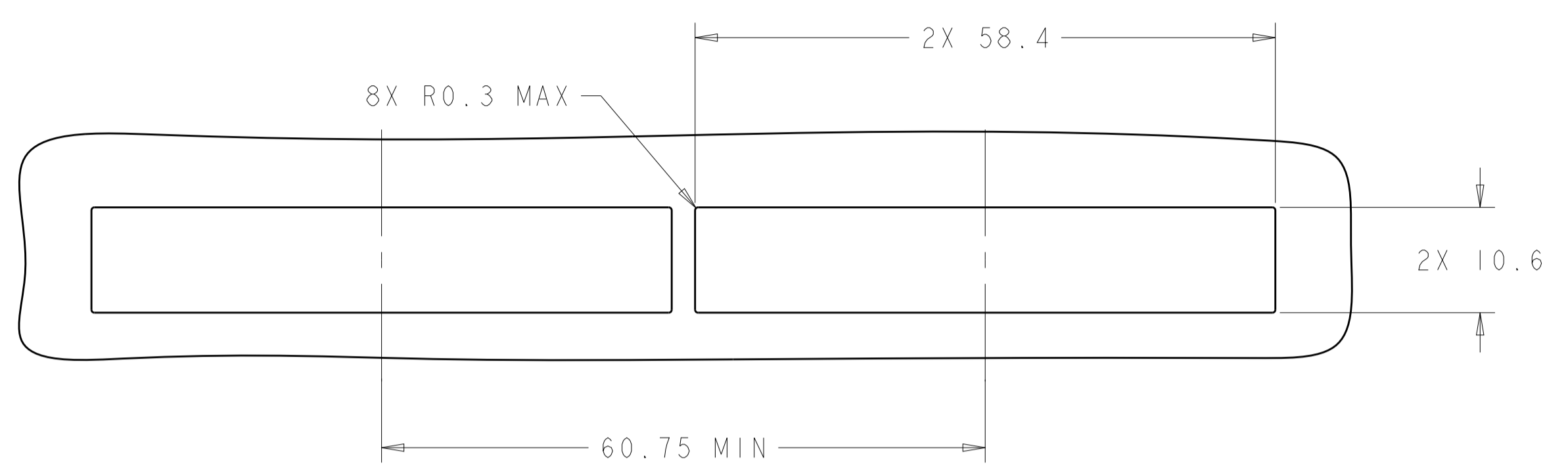

RECOMMENDED BEZEL OPENING  
 SINGLE SIDED APPLICATIONS  
 SCALE 2:1

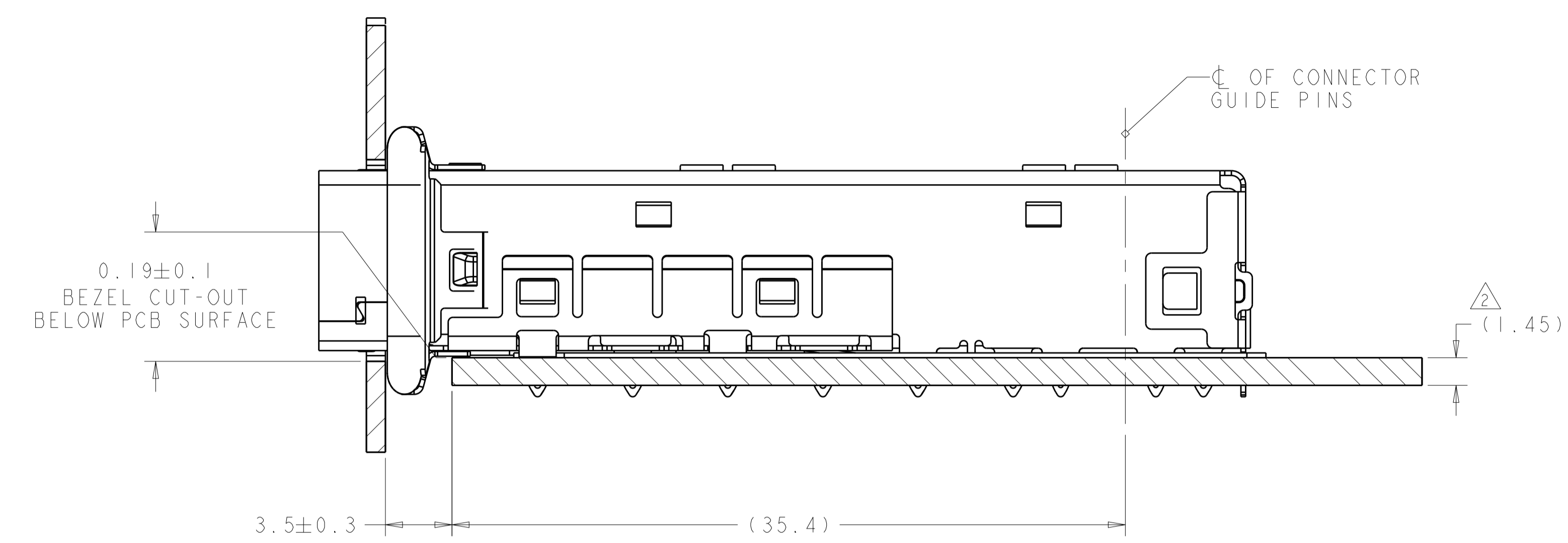

MOUNTED ON PC BOARD  
 SHOWN THRU RECOMMENDED BEZEL  
 SCALE 5:1

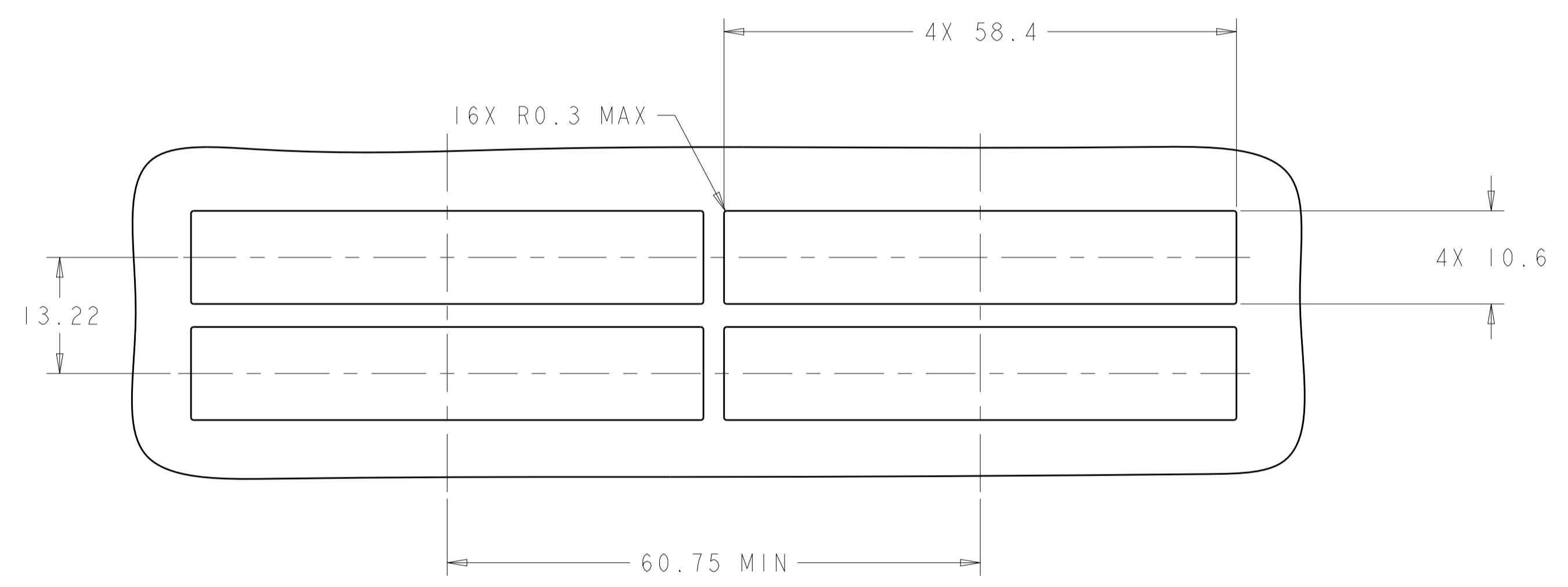

RECOMMENDED BEZEL OPENING  
 BELLY TO BELLY APPLICATIONS  
 SCALE 2:1

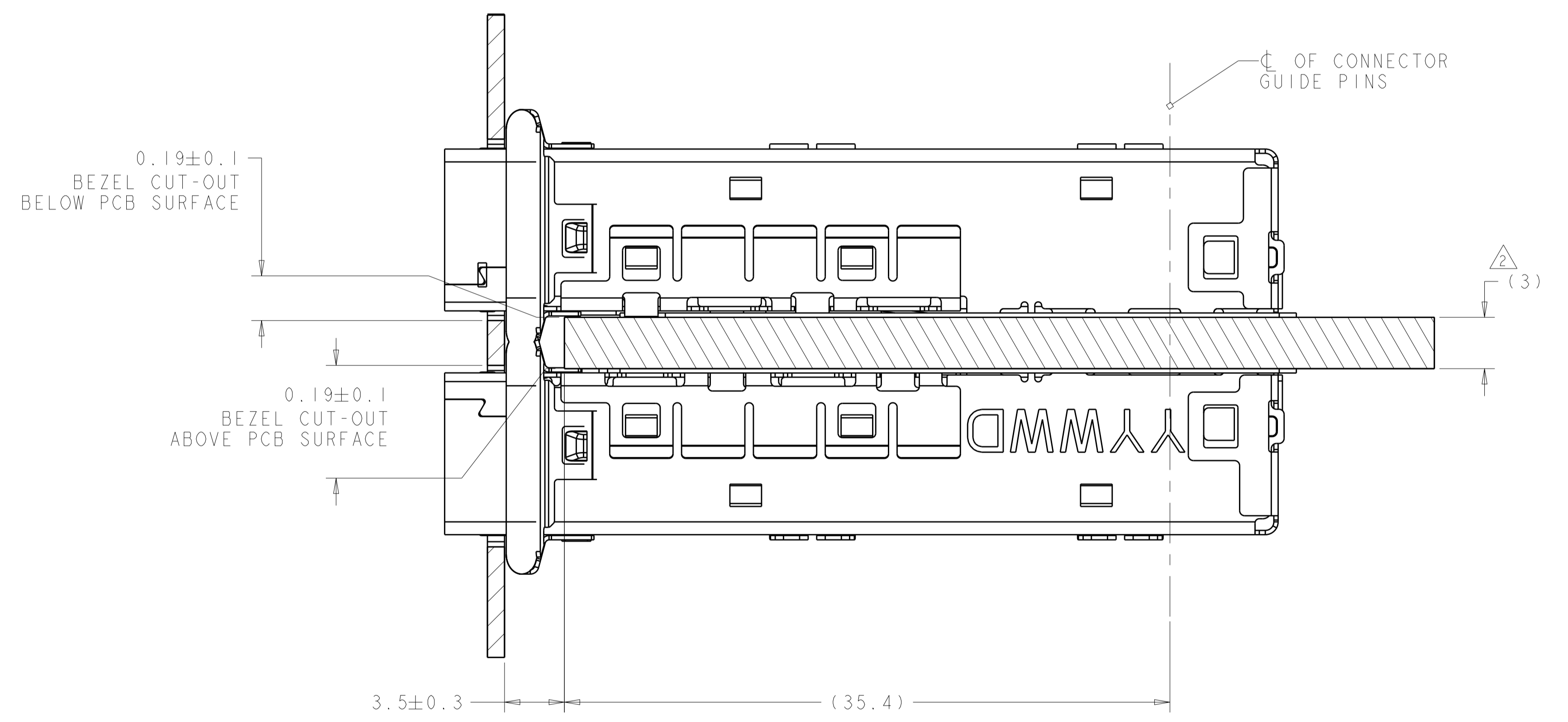

MOUNTED BELLY TO BELLY ON PC BOARD  
 SHOWN THRU RECOMMENDED BEZEL  
 SCALE 5:1

THIS DRAWING IS A CONTROLLED DOCUMENT.		DMN M.E. CONNER 27DEC2012	TE Connectivity
DIMENSIONS: mm		CHK M.D. MORRISON 01FEB2013	
TOLERANCES UNLESS OTHERWISE SPECIFIED:		APVD M.J. PHILLIPS 01FEB2013	NAME CAGE ASSEMBLY, ENHANCED, PRESS-FIT, 1X4, zSFP+
0 PLC ±0.25	1 PLC ±0.25	PRODUCT SPEC 108-2364	SIZE CAGE CODE DRAWING NO RESTRICTED TO
2 PLC ±0.25	3 PLC ±0.25	APPLICATION SPEC 114-13120	A100779C=2198722
4 PLC ±0.25	ANGLES ±°	WEIGHT	SCALE 5:1 SHEET 2 OF 4 REV B
MATERIAL SEE NOTE 1	FINISH	Customer Drawing	

LOC	DIST	REVISIONS			
GP	00	REV	DATE	BY	APPV
		1	SEE SHEET 1		

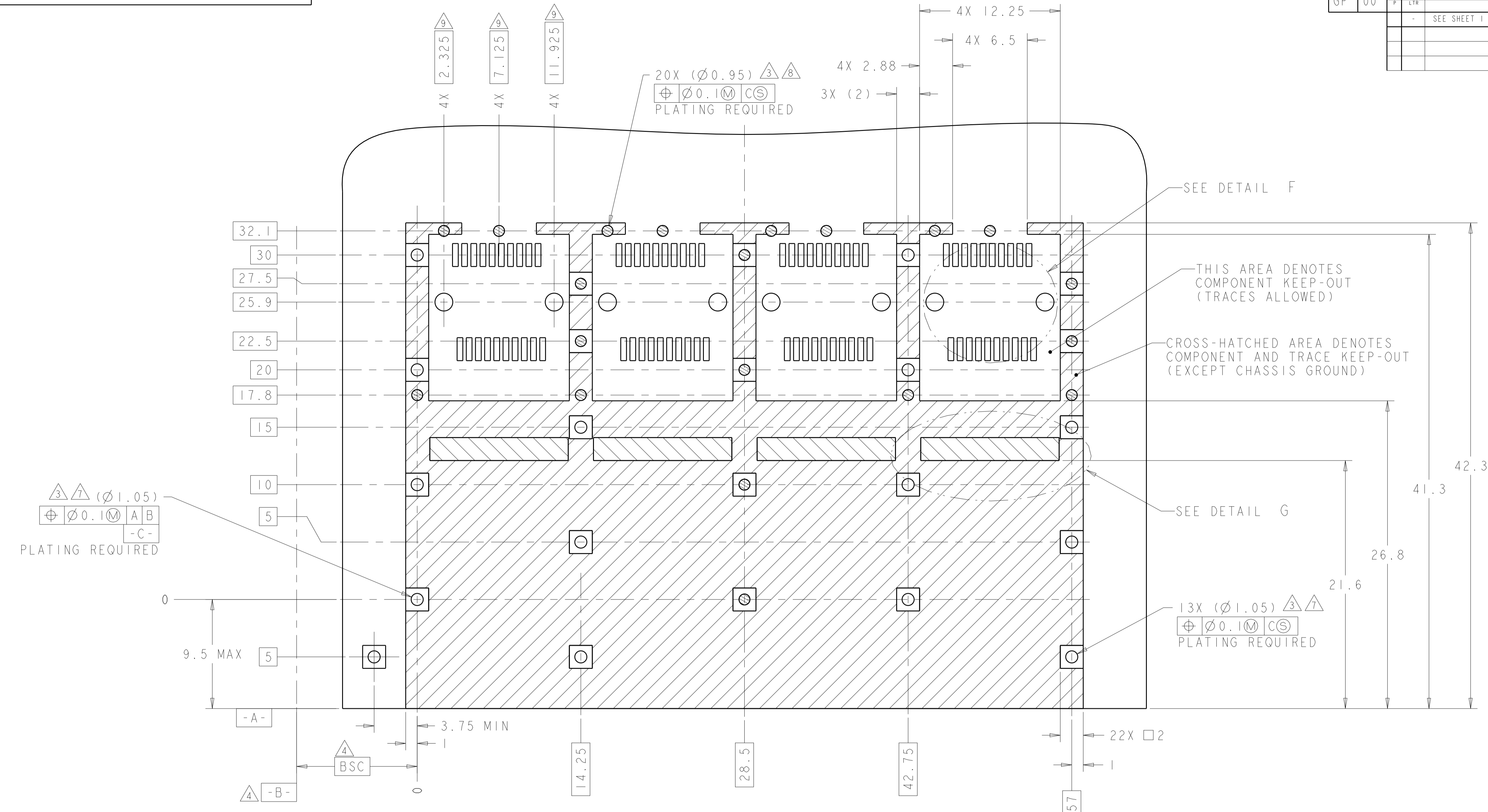

RECOMMEND PCB CONFIGURATION WITH KEEP-OUT AREAS FOR SINGLE SIDED APPLICATIONS  
 SCALE 5:1

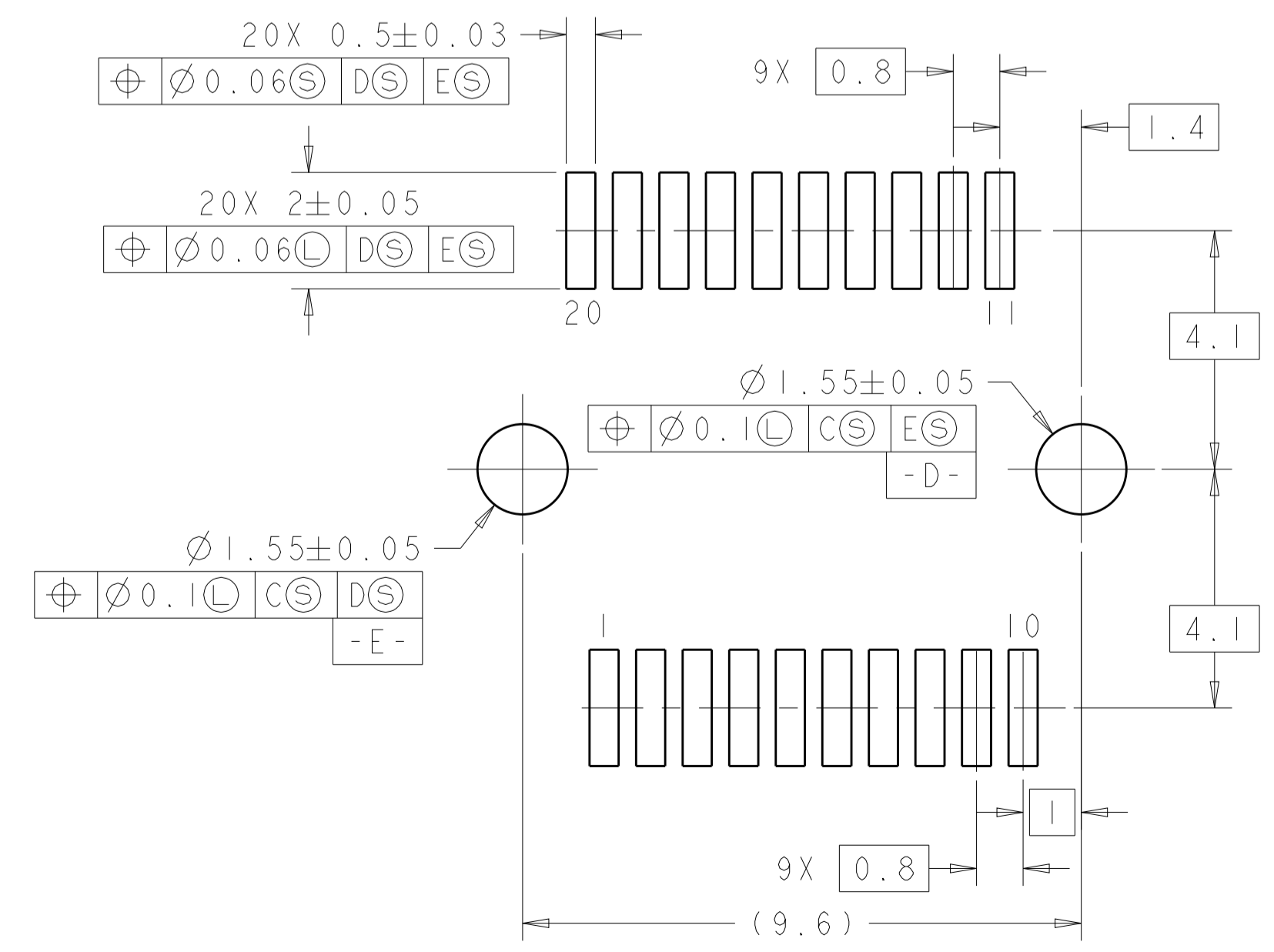

DETAIL F  
 4X INDIVIDUALLY  
 SCALE 10:1

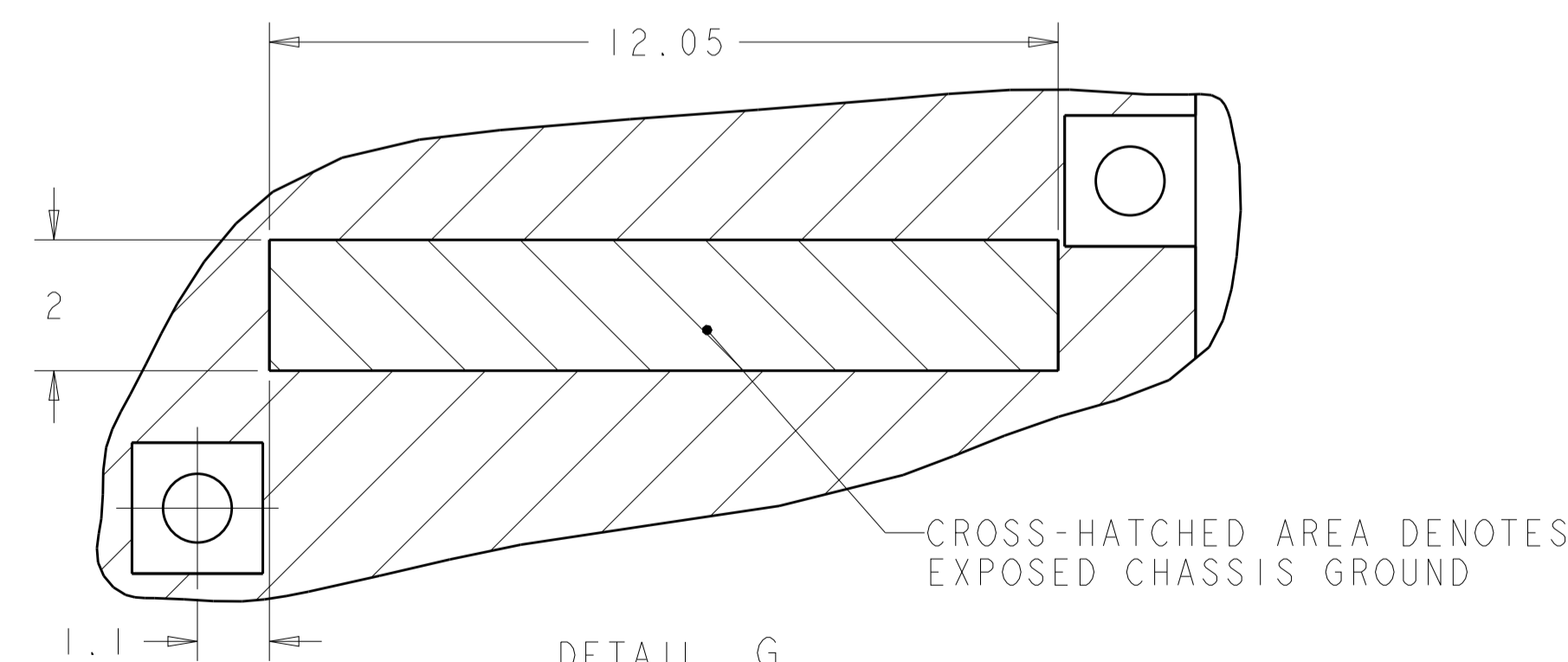

DETAIL G  
 4X INDIVIDUALLY  
 SCALE 10:1

THIS DRAWING IS A CONTROLLED DOCUMENT.		OWN: M.E. CONNER 27DEC2012	TE Connectivity
DIMENSIONS: mm		CHK: M.D. MORRISON 01FEB2013	
TOLERANCES UNLESS OTHERWISE SPECIFIED:		APVD: M.J. PHILLIPS 01FEB2013	NAME: CAGE ASSEMBLY, ENHANCED, PRESS-FIT, 1X4, zSFP+
0 PLC ±0.1	1 PLC ±0.1	PRODUCT SPEC: 108-2364	SIZE: A100779C=2198722
2 PLC ±0.08	3 PLC ±0.05	APPLICATION SPEC: 114-13120	RESTRICTED TO: -
4 PLC ±	ANGLES ±1°	WEIGHT: -	SCALE: 5:1 SHEET 3 OF 4 REV B
MATERIAL: SEE NOTE 1	FINISH: -	Customer Drawing	

LOC	DIST	REVISIONS			
P	LTN	DESCRIPTION	DATE	OWN	APVD
-	-	SEE SHEET 1	-	-	-

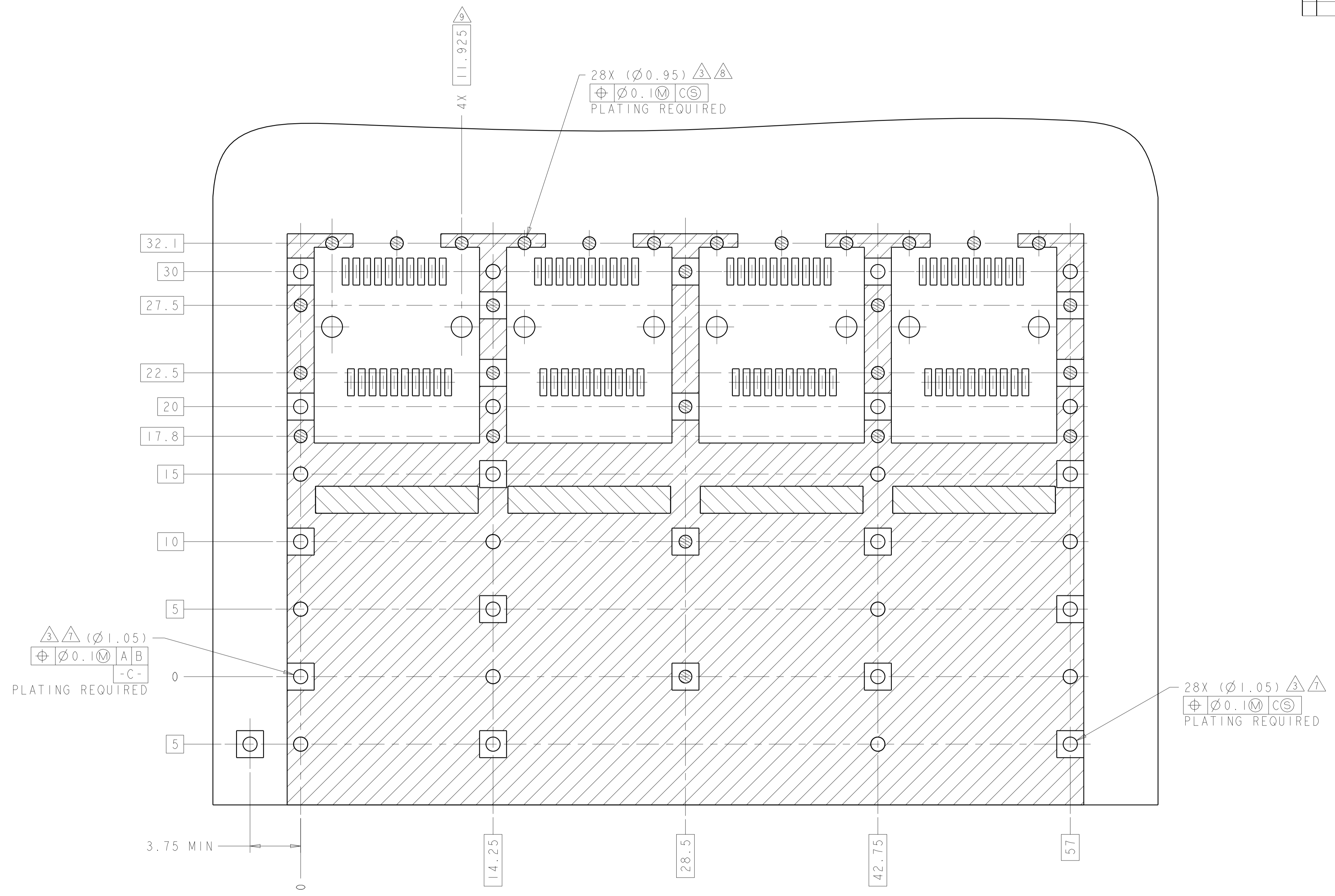

RECOMMEND PCB CONFIGURATION WITH KEEP-OUT AREAS FOR BELLY TO BELLY APPLICATIONS  
 SAME AS SINGLE SIDE APPLICATION, EXCEPT AS SHOWN  
 SCALE 6:1

THIS DRAWING IS A CONTROLLED DOCUMENT.		OWN: M.E. CONNER 27DEC2012	TE Connectivity
DIMENSIONS: mm		CHK: M.D. MORRISON 01FEB2013	
TOLERANCES UNLESS OTHERWISE SPECIFIED: 0 PLC ±0.1 1 PLC ±0.1 2 PLC ±0.08 3 PLC ±0.05 4 PLC ±0.05 ANGLES ±°		APVD: M.J. PHILLIPS 01FEB2013	NAME: CAGE ASSEMBLY, ENHANCED, PRESS-FIT, 1X4, zSFP+
MATERIAL: SEE NOTE 1		PRODUCT SPEC: 108-2364	SIZE: A100779
FINISH: -		APPLICATION SPEC: 114-13120	CAGE CODE: C=2198722
WEIGHT: -		RESTRICTED TO: -	SCALE: 5:1
Customer Drawing		DATE: -	SHEET: 4 OF 4
		REV: -	REV: B

单击下面可查看定价，库存，交付和生命周期等信息

[>>TE Connectivity\(泰科\)](#)