

THIS DRAWING IS UNPUBLISHED. RELEASED FOR PUBLICATION
 © COPYRIGHT BY TYCO ELECTRONICS CORPORATION. ALL INTERNATIONAL RIGHTS RESERVED.

LOC	DIST	REVISIONS					
		P	LTR	DESCRIPTION	DATE	DWN	APVD
G	14		G1	REVISED PER ECR-09-009459	11JUN09	HMR	JR

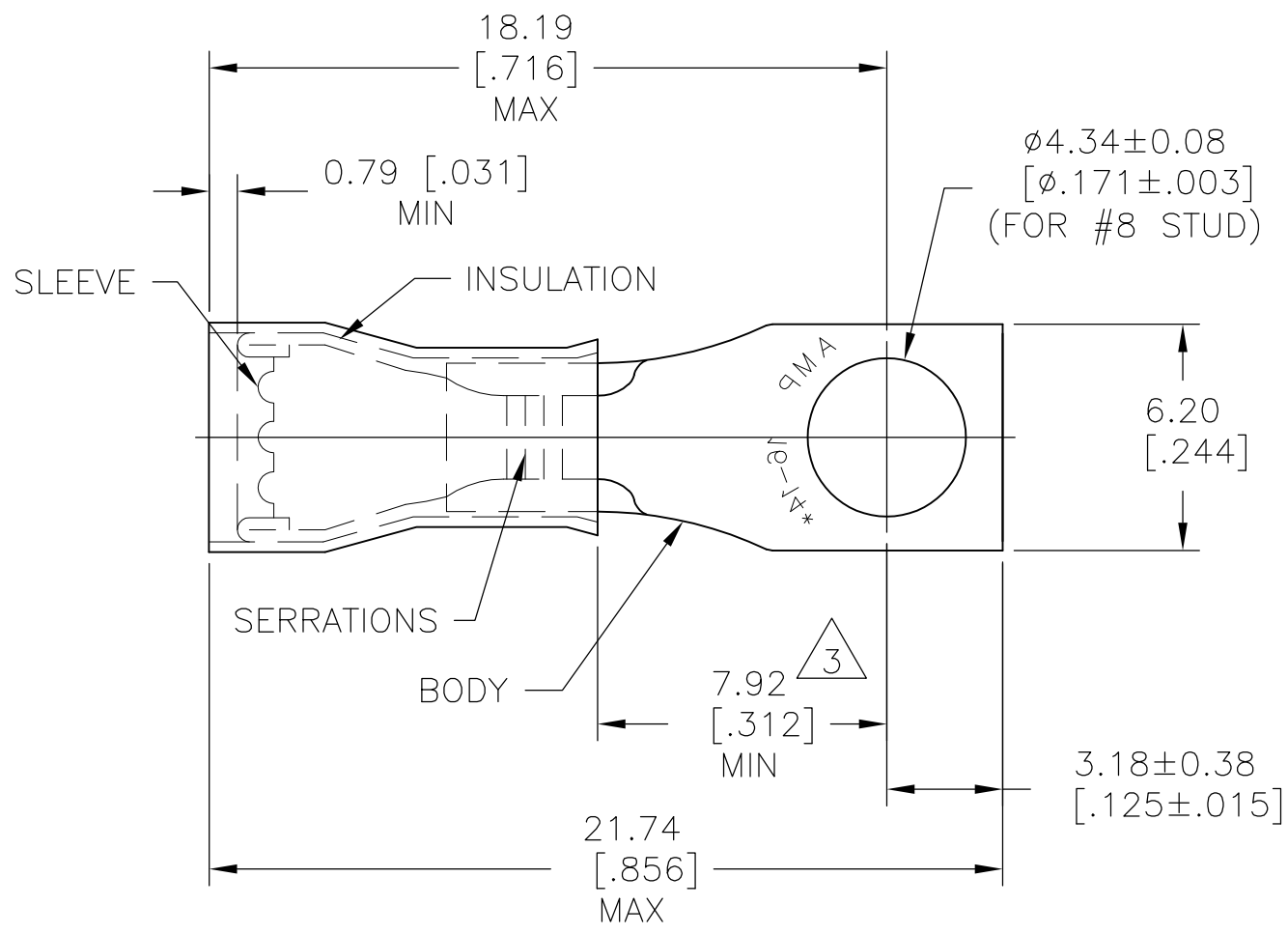

- 1 FOR 2.92[.115] TO 4.32[.170] WIRE INSULATION DIA
- 2 TONGUE MATERIAL THK 0.79±0.05[.031±.002]
- △3 APPLIES FROM EDGE OF METAL BARREL TO CENTERLINE OF STUD HOLE.
- △4 SUPERSEDED BY 35279

QTY	DESCRIPTION	MATERIAL & FINISH	PART NO
1	35279 ON TAPE	INSULATION: NYLON COLOR: BLUE	△4 2-35279-1
1	WIRE TERMINAL	SLEEVE: COPPER ASTM-B152 BODY: COPPER ASTM-B152 TIN PL ASTM-B545	35279

THIS DRAWING IS A CONTROLLED DOCUMENT.		DWN RAGHAVEDRA 11JUN09	Tyco Electronics Corporation Harrisburg, PA 17105-3608	
DIMENSIONS: mm [INCHES]		CHK JEFF RUTH 11JUN09	NAME WIRE TERMINAL PIDG - RECTANGULAR TONGUE WIRE SIZE: 16-14	
TOLERANCES UNLESS OTHERWISE SPECIFIED:		APVD TOM MICHIELUTTI 11JUN09	PRODUCT SPEC -	
0 PLC ± -		APPLICATION SPEC -		
1 PLC ± -		SIZE A3 CAGE CODE 00779 DRAWING NO G-35279 RESTRICTED TO -		
2 PLC ± -		SCALE 5:1 SHEET 1 OF 1 REV G1		
3 PLC ± 0.20[.008]				
4 PLC ± -				
ANGLES ± .5°				
MATERIAL -	FINISH -	CUSTOMER DRAWING		

单击下面可查看定价，库存，交付和生命周期等信息

[>>TE Connectivity\(泰科\)](#)