

THIS DRAWING IS UNPUBLISHED. RELEASED FOR PUBLICATION 20
 © COPYRIGHT 20 BY TYCO ELECTRONICS CORPORATION. ALL RIGHTS RESERVED.

LOC	DIST	REVISIONS					
GP	00	P	LTR	DESCRIPTION	DATE	DWN	APVD
		B		REV PER ECO-08-012478	21MAY2008	RG	PD

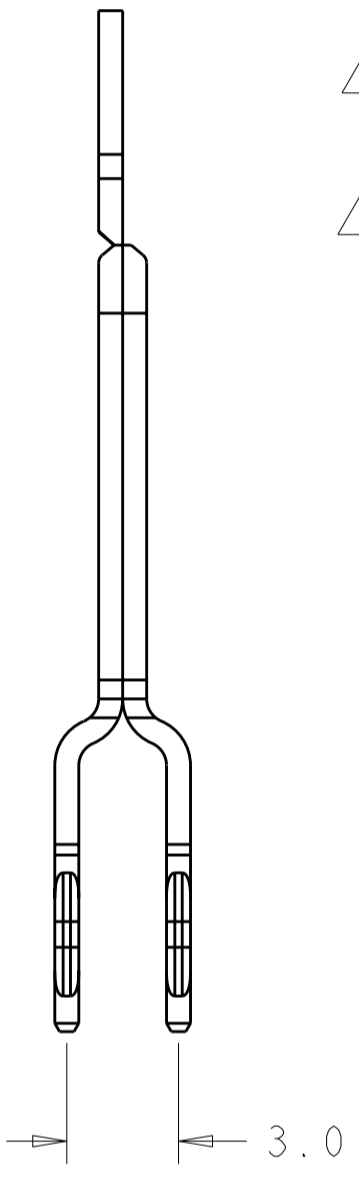
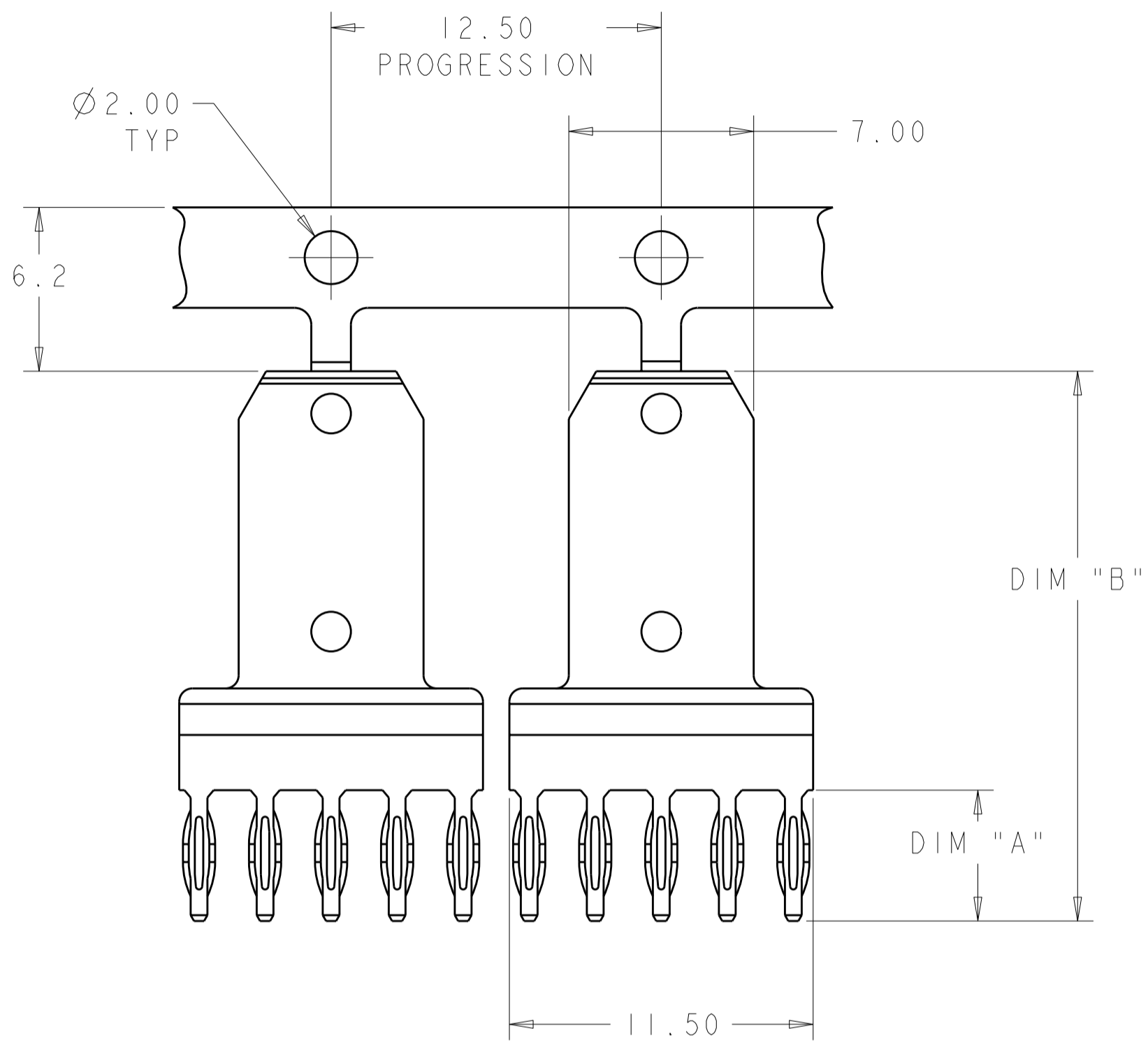

1. PART NUMBER CHANGES AND/OR DESIGN CHANGES AFFECTING ITEM INTERCHANGEABILITY REQUIRES PRIOR TYCO ELECTRONICS APPROVAL AND AUTHORIZATION BY REVISION TO THIS DRAWING.

2. MATERIAL:
PHOSPHOR BRONZE ALLOY

3. FINISH:
CONTACT - GOLD PLATE 0.76µm MIN THK. OVER
NICKEL 1.27µm MIN THK.
COMPLAINT TAILS - TIN PLATE 1.02µm MIN THK. OVER
NICKEL 1.27µm MIN THK.

4. ITEMS PROVIDED TO THIS SPECIFICATION TO BE PERMANENTLY IDENTIFIED ON THE CONTAINER PER THE FOLLOWING IDENTIFIER:

TYCO ELECTRONICS P/N: XXXXXXXX-X
 DATE CODE (e.g. 0216): YEAR 1 WEEK 1
 XXXX

20.80	4.95	1766868-2
22.70	6.85	1766868-1
DIM "B"	DIM "A"	PART NO.

THIS DRAWING IS A CONTROLLED DOCUMENT FOR TYCO ELECTRONICS CORPORATION. IT IS SUBJECT TO CHANGE AND THE CONTROLLING ENGINEERING ORGANIZATION SHOULD BE CONTACTED FOR THE LATEST REVISION.		DWN R. GRZYBOWSKI 30 JAN 2008	Tyco Electronics Harrisburg, PA 17105-3608	
DIMENSIONS: mm		CHK P. DAMATO 30 JAN 2008	NAME POWER CONTACT, DISCRETE BLADE PCB MOUNT COMPLIANT TAIL	
TOLERANCES UNLESS OTHERWISE SPECIFIED: 0 PLC ± 1 PLC ±0.5 2 PLC ±0.25 3 PLC ± 4 PLC ± ANGLES ±3		APVD S. FLICKINGER 30 JAN 2008	RESTRICTED TO	
MATERIAL		PRODUCT SPEC	SIZE A2	CAGE CODE 00779
FINISH		APPLICATION SPEC	DRAWING NO 1766868	REV B
CUSTOMER DRAWING		WEIGHT	SCALE 3:1	SHEET 1 OF 1

单击下面可查看定价，库存，交付和生命周期等信息

[>>TE Connectivity\(泰科\)](#)