

DESIGNED FOR USE WITH .085 S.R.	
CABLE ENTRY DIAMETER MINIMUM	
CLAMP NUT	.089
SLEEVE	.064
CONTACT	.021

REVISIONS			
REV	DESCRIPTION	DATE	APPROVED
01 ₀	RELEASED	11-3-97	KYLE

RECOMMENDED
MOUNTING HOLE

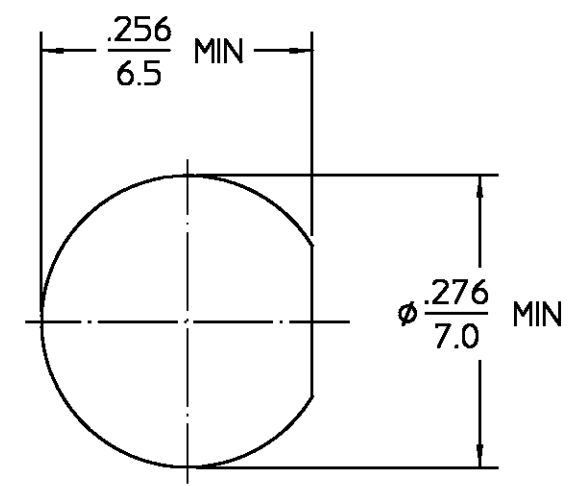

SLEEVE	STAINLESS STEEL PER ASTM-A484 AND ASTM- A582, TYPE 303	GOLD PLATE PER MIL-G-45204
HOUSING CLAMP NUT MOUNTING NUT BUSHING	STAINLESS STEEL PER ASTM-A484 AND ASTM- A582, TYPE 303	PASSIVATE PER QQ-P-35
DIELECTRIC	PTFE FLUOROCARBON PER ASTM-D-1457	N/A
CENTER CONTACT	BERYLLIUM COPPER PER ASTM-B-196 OR ASTM-B-197, ALLOY C17300, CONDITION H	GOLD PLATE PER MIL-G-45204
LOCKWASHER	BERYLLIUM COPPER PER ASTM-B-196, ALLOY C17300, CONDITION H	GOLD PLATE PER MIL-G-45204
CAP	VINYL PLASTIC	N/A
COMPONENT	MATERIAL	FINISH

UNLESS OTHERWISE SPECIFIED
DIMENSIONS ARE IN INCHES

FRAC.	DEC.	ANGLES
± 1/64	±.005	± 1°

DRAWN BY	DATE
KYLE LE	11-3-97
CHECKED BY	
APPD BY	

AMP Incorporated
140 Fourth Avenue
Waltham, MA 02451-7599

NOTES:
1. CAPTURED CENTER CONTACT

.XXX = in
XX.X = mm (REF)

These drawings and specifications are the property of M/A COM Interconnect Div. and shall not be reproduced or copied or used in whole or in part as the basis for the manufacture or sale of item(s) without written permission.

USE ASSY PROCEDURE
408-04616
(85-002)
NO. A.P. _____

TITLE "OS-50" BULKHEAD FEEDTHRU CABLE JACK CLAMP ATTACHMENT			
SIZE B	CODE IDENT NO. 26805	1250-2734-02	REV 01 ₀
SCALE 6:1			SHEET 1 OF 1

DESIGN CONTROL REQUIRED

CUSTOMER DRAWING

AMP PART # 1083600-1
SHEET 1 OF 1 REV A

单击下面可查看定价，库存，交付和生命周期等信息

[>>TE Connectivity\(泰科\)](#)