

THIS DRAWING IS UNPUBLISHED. RELEASED FOR PUBLICATION
 © COPYRIGHT - By - ALL RIGHTS RESERVED.

LOC	DIST	REVISIONS					
GP	00	P	LTR	DESCRIPTION	DATE	DWN	APVD
		P		REVISED PER ECO-11-005033	23MAR11	RK	HMR

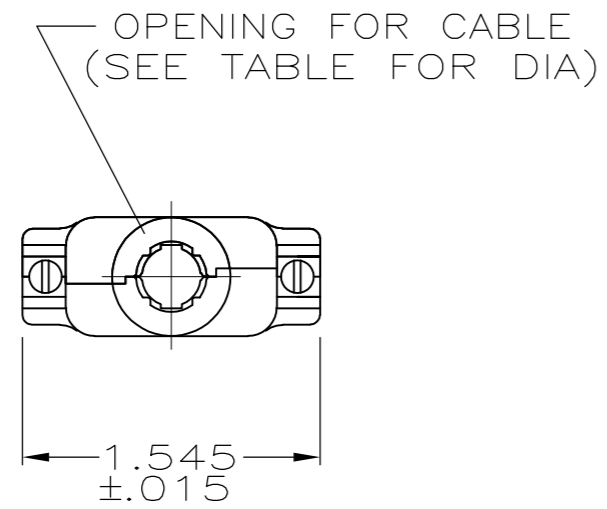

- 1. PARTS PACKAGED UNASSEMBLED.
- 2. ZINC PLATED .000200-.000400 THICK, CLEAR CHROMATE COATING.

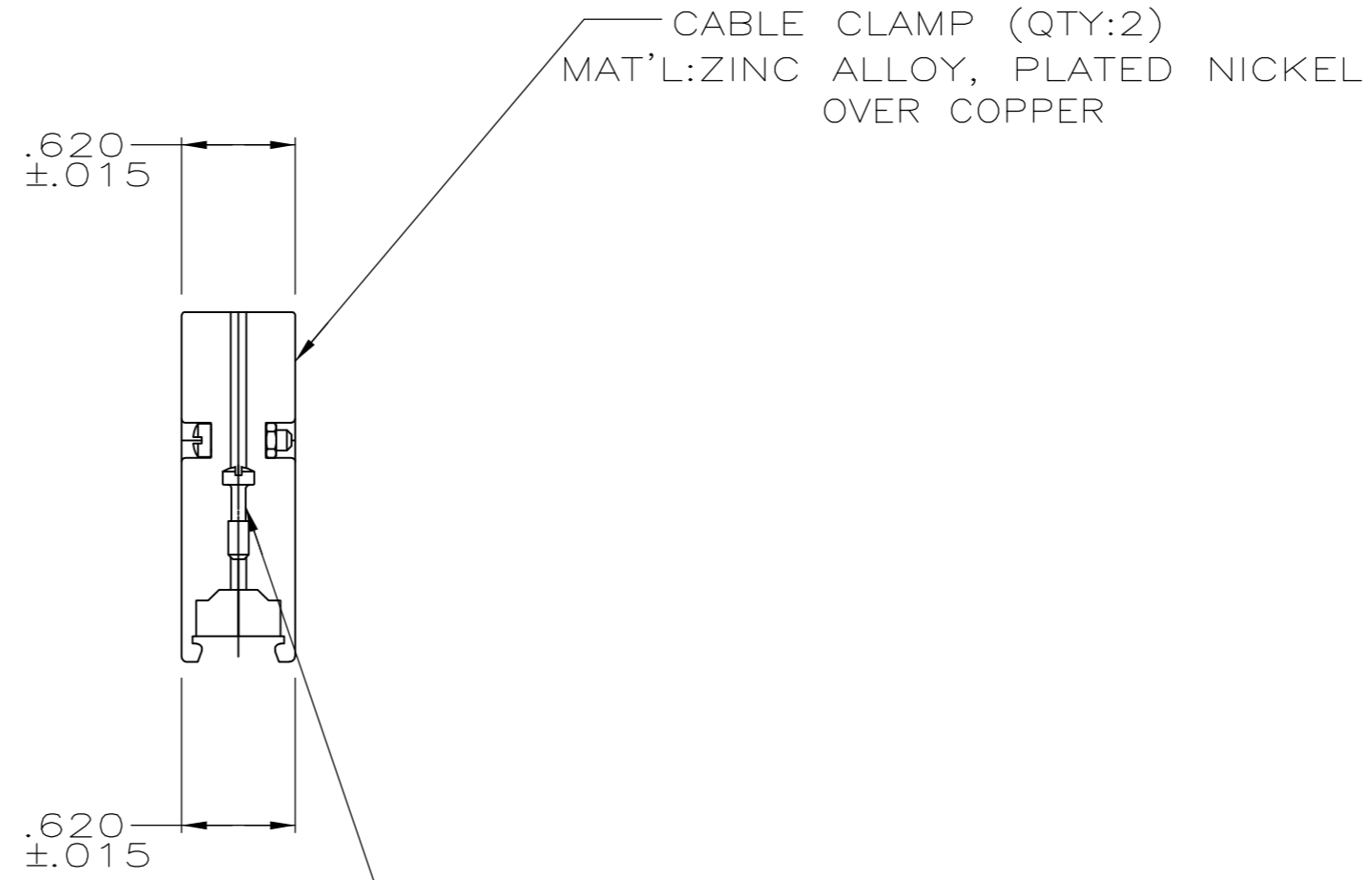
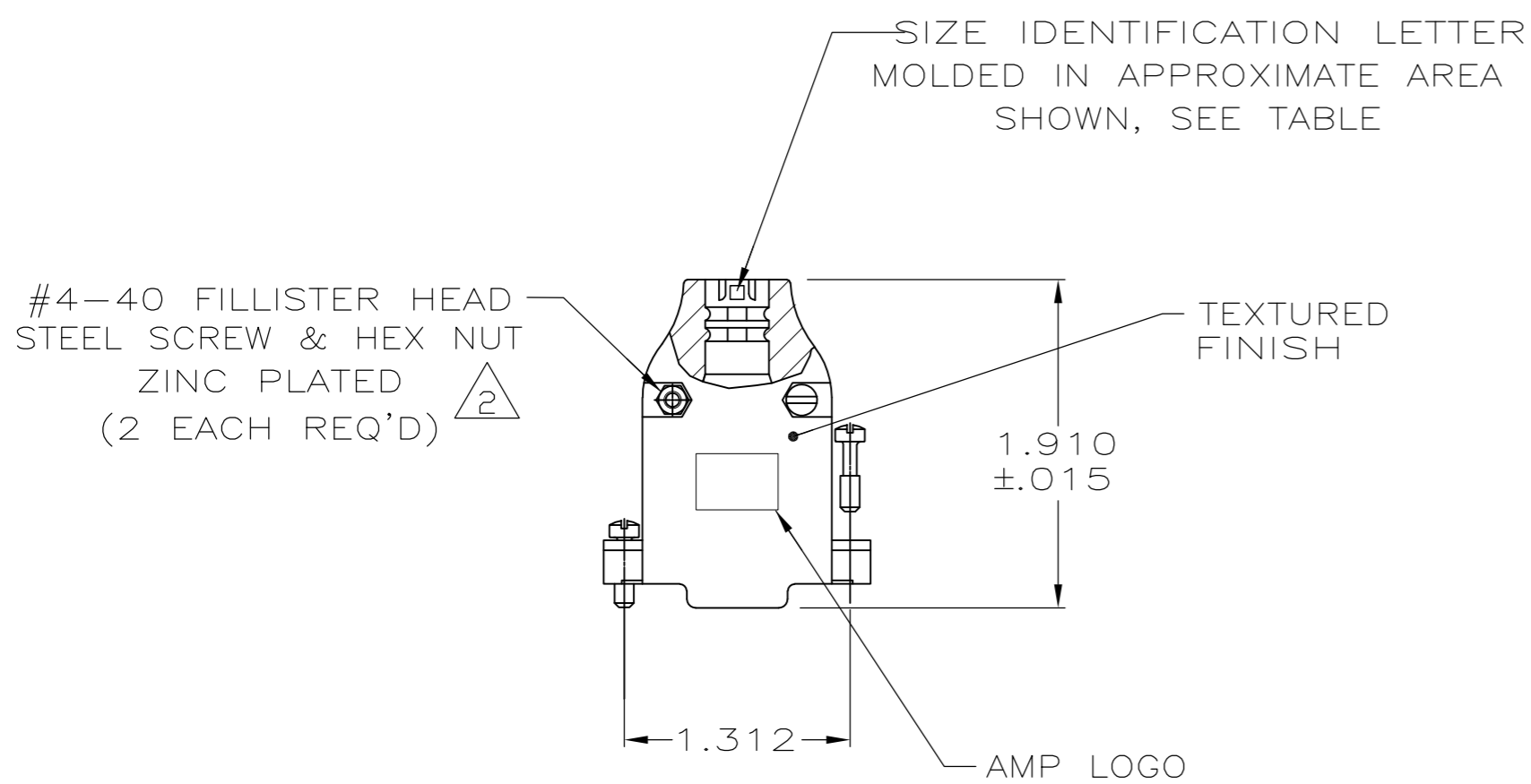

#4-40 FILLISTER HD SCREW
MAT'L: STEEL, 2

K	.430	1-5745172-3
B	.225	5745172-3
E	.300	5745172-2
H	.375	5745172-1
NECK IDENT	CABLE DIA	PART NO

THIS DRAWING IS A CONTROLLED DOCUMENT.		DWN B. MCMASTER 02AUG05														
DIMENSIONS: INCHES		CHK J. GERACE 02AUG05														
TOLERANCES UNLESS OTHERWISE SPECIFIED:		APVD M. WALMSLEY 02AUG05	NAME CABLE CLAMP KIT, UNASSEMBLED, SIZE 2, 15 POSITION, 180 DEGREES, AMPLIMITE													
<table border="1"> <tr><td>0 PLC</td><td>± -</td></tr> <tr><td>1 PLC</td><td>± -</td></tr> <tr><td>2 PLC</td><td>± -</td></tr> <tr><td>3 PLC</td><td>± .005</td></tr> <tr><td>4 PLC</td><td>± -</td></tr> <tr><td>ANGLES</td><td>± -</td></tr> </table>		0 PLC	± -	1 PLC	± -	2 PLC	± -	3 PLC	± .005	4 PLC	± -	ANGLES	± -	PRODUCT SPEC -	RESTRICTED TO -	
0 PLC	± -															
1 PLC	± -															
2 PLC	± -															
3 PLC	± .005															
4 PLC	± -															
ANGLES	± -															
MATERIAL SEE CALLOUTS		FINISH SEE CALLOUTS	WEIGHT -	SIZE A2												
CUSTOMER DRAWING		SCALE 1:1	CAGE CODE 00779	DRAWING NO 5745172												
		SHEET 1 of 1	REV P													

单击下面可查看定价，库存，交付和生命周期等信息

[>>TE Connectivity\(泰科\)](#)