

THIS DRAWING IS UNPUBLISHED. RELEASED FOR PUBLICATION
 © COPYRIGHT BY TYCO ELECTRONICS CORPORATION. ALL RIGHTS RESERVED.

LOC	DIST	REVISIONS					
		P	LTR	DESCRIPTION	DATE	DWN	APVD
G	14		A1	REV PER ECR 07-010957	11MAY07	JR	TM

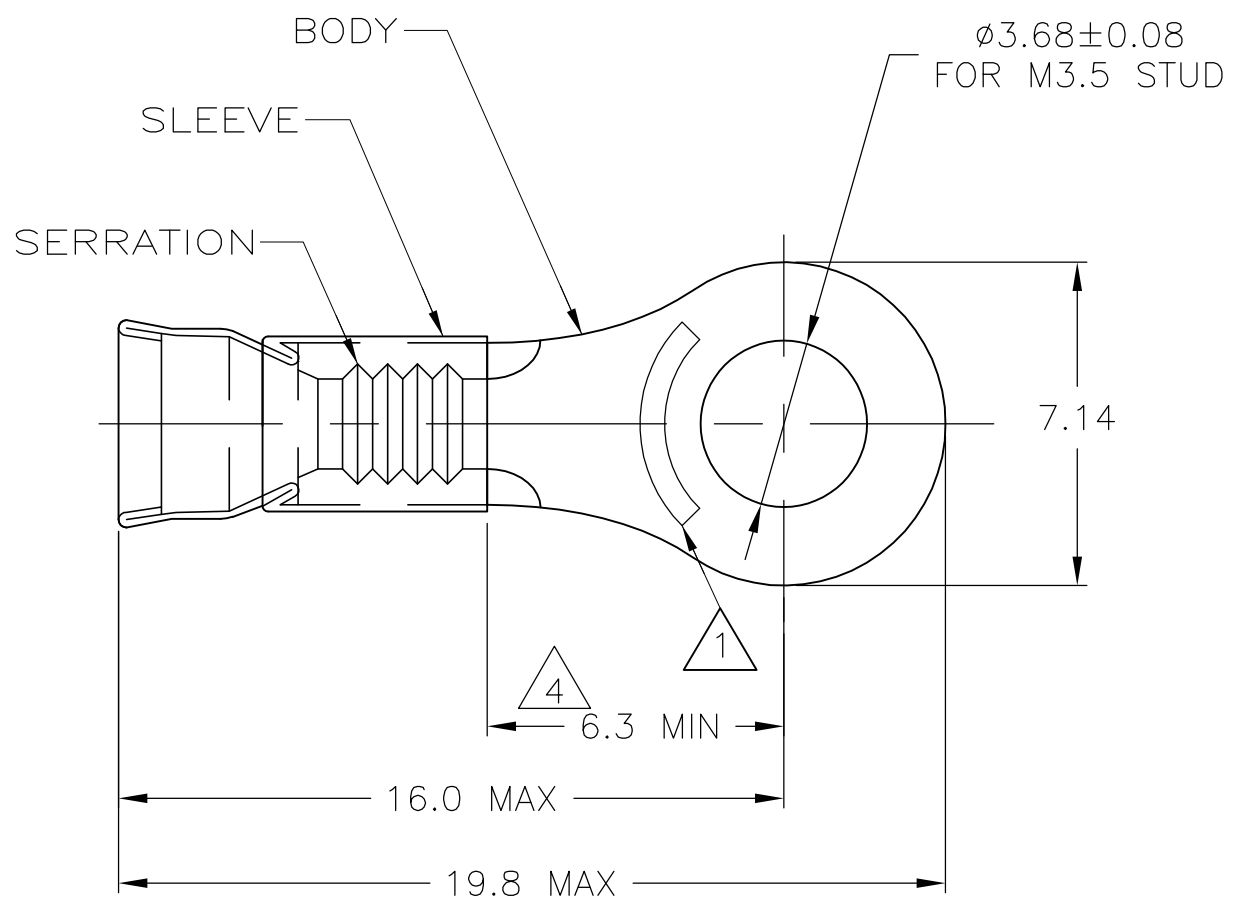

- 1 STAMP AMP 22-18* APPROX AS SHOWN
 22-16 TERMINALS ARE STAMPED 22-18 IN
 ACCORDANCE WITH MILITARY SPEC MIL-T-7928
 COMMERCIAL WIRE RANGE IS 22-16
- 2. WIRE INSUL DIA, 1.3-2.8
- 3. TONGUE MATL THK, 0.79±0.05
- 4 APPLIES FROM EDGE OF METAL WIRE BARREL
 TO CENTER OF STUD HOLE
- 5 MATERIAL:
 BODY - COPPER PER ASTM B152
 SLEEVE - NICKEL SILVER PER ASTM B122
- 6 FINISH:
 BODY - NICKEL PLATE PER QQ-N-290
 SLEEVE - NONE

5000	ON TAPE	2-150492-1
1000	LOOSE PIECE	150492
QTY	PACKAGE TYPE	PART NO

THIS DRAWING IS A CONTROLLED DOCUMENT.		DWN	JR RUTH	11MAY07	Tyco Electronics Corporation Harrisburg, PA 17105-3608			
DIMENSIONS: mm		CHK	T MICHIELUTTI	11MAY07				
		TOLERANCES UNLESS OTHERWISE SPECIFIED:		APVD	NAME			
0 PLC ± - 1 PLC ± - 2 PLC ± 0.20 3 PLC ± - 4 PLC ± - ANGLES ± -		PRODUCT SPEC - APPLICATION SPEC -		T MICHIELUTTI		TERMINAL, RING TONGUE, STRATOTHERM, DIAMOND GRIP, 22-16 AWG		
MATERIAL		FINISH		WEIGHT	SIZE	CAGE CODE	DRAWING NO	RESTRICTED TO
- 5		- 6		-	A3	00779	G-150492	-
CUSTOMER DRAWING				SCALE	6:1	SHEET	1 OF 1	REV
								A1

单击下面可查看定价，库存，交付和生命周期等信息

[>>TE Connectivity\(泰科\)](#)