

LOC	DIST	REVISIONS			
CM	00	REV	DATE	BY	APPV
		T2	18JUN2018	BDA	SG
		U	18OCT2019	BDA	SW

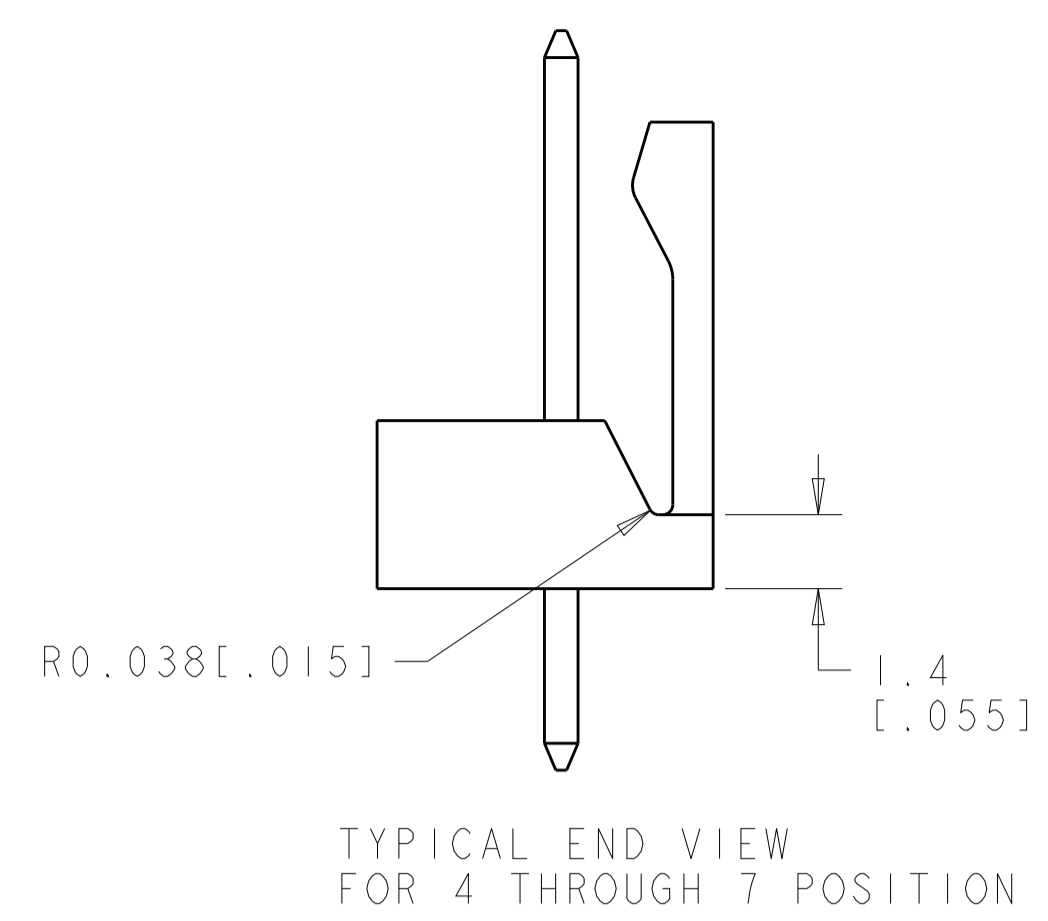

- 1. POST WITHSTAND 13 NEWTONS (3 LBS) MIN AXIAL FORCE IN DIRECTION SHOWN WITHOUT DISLODGING.
- 2. MEASURED AT -A-.
- 3. PARTS COMPLY WITH SOLDERABILITY SPEC 109-11-2/12.
- 4. MATERIAL: HOUSING: NYLON, 4/6, HIGH TEMP, BLACK.
POST -2 THRU -12 COPPER ALLOY BRIGHT TIN-LEAD 0.00305 [0.000120] MIN THICK.
POST -32 THRU -42 COPPER ALLOY MATTE TIN 0.00305 [0.000120] MIN THICK.
- 5. COORDINATE DIMENSION APPLIES FROM CENTER OF ACTUAL FEATURE.
- 6. POSTS TO BE MEASURED WHEN STRIP HELD FLAT.
- 7. DIMENSIONS IN BRACKETS ARE IN INCHES.
- 8. TOLERANCES APPLY TO SOLDER SIDE OF BOARD.
- 9. ONE HOLE MAY BE UNDERSIZED 0.81-0.89 [0.032-.035] DIAMETER FOR ASSEMBLY RETENTION DURING PROCESSING.
- 10. TE LOGO, UL, AND CSA TRADEMARKS TO APPEAR ON THIS SURFACE.

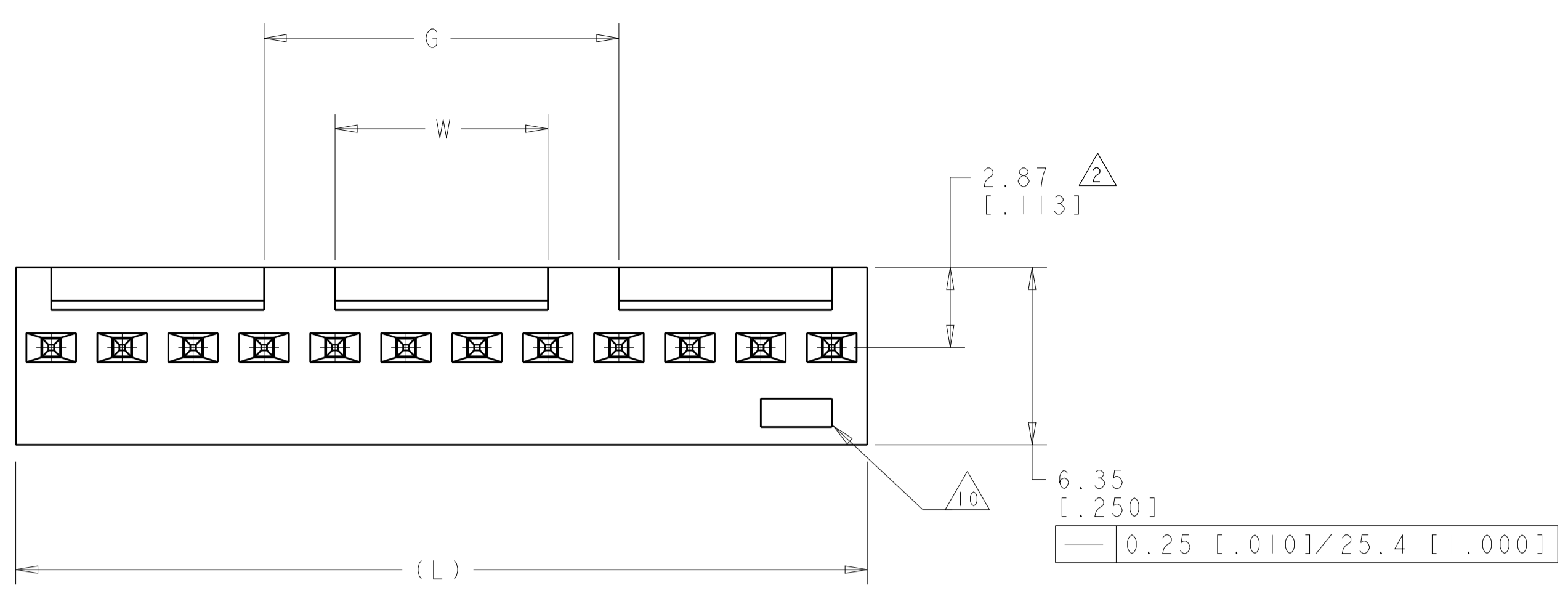
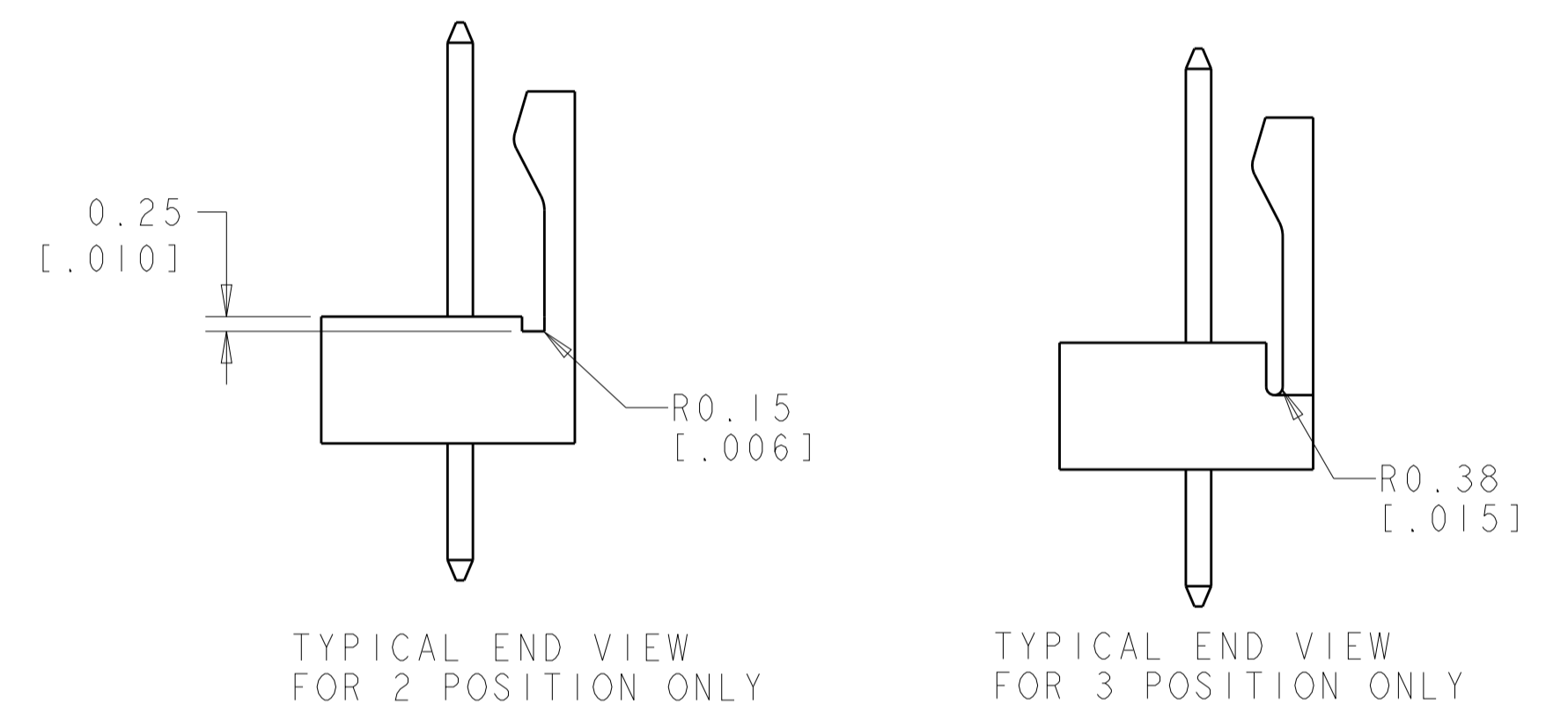
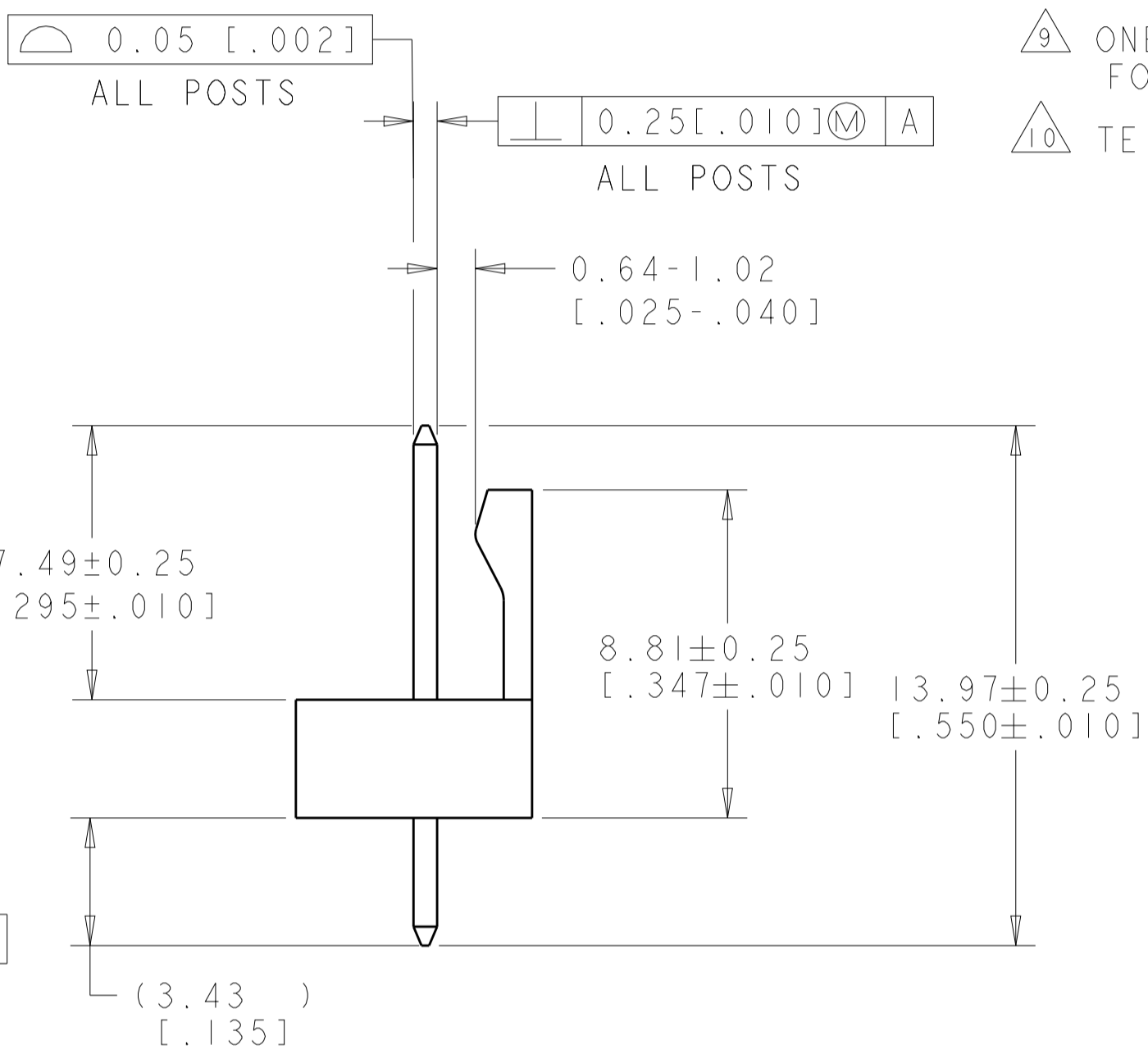
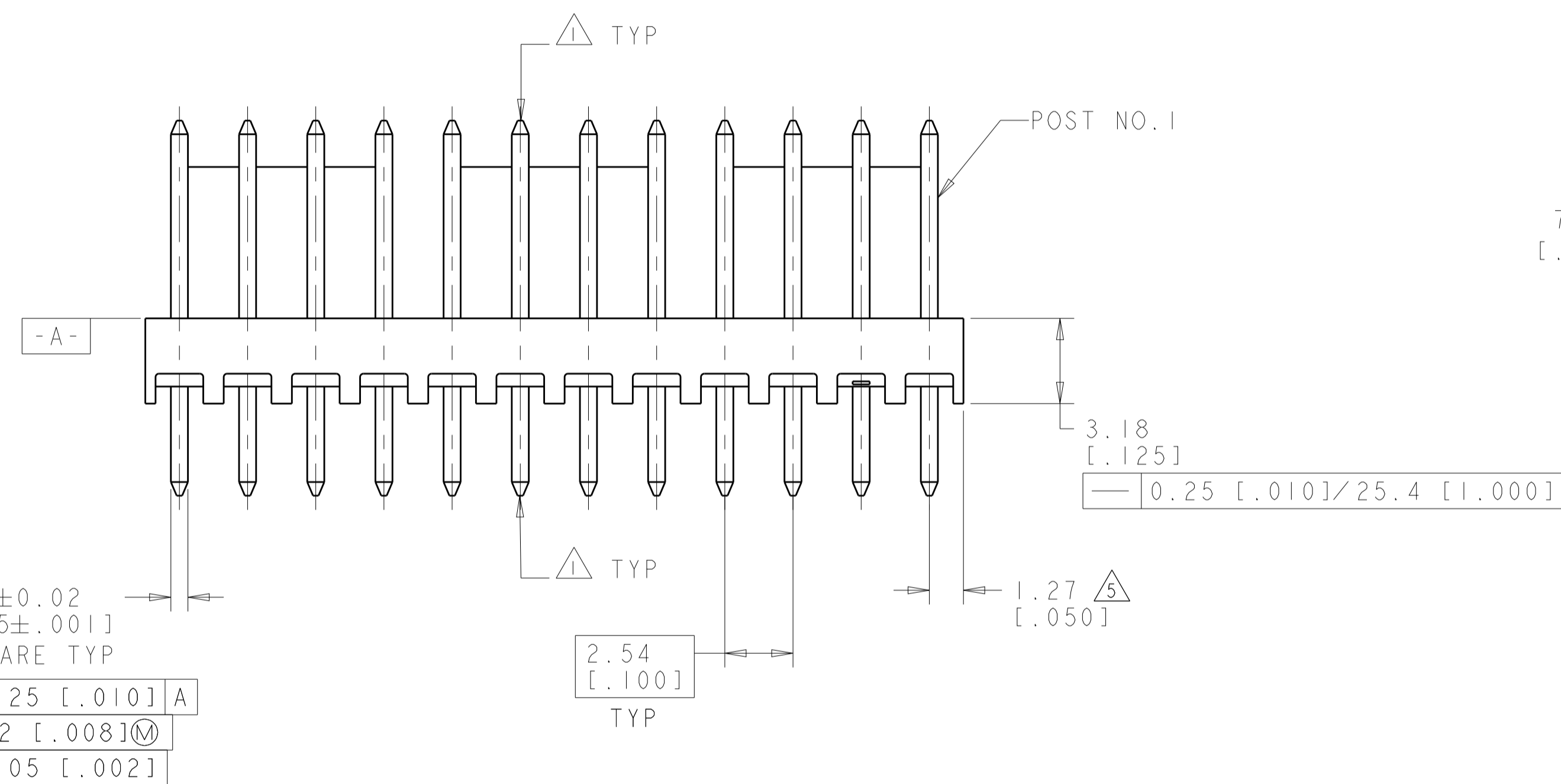

0.64±0.02 [.025±.001] SQUARE TYP	0.25 [0.010] A
0.2 [0.008] M	
0.05 [0.002]	

0.25 [0.010] A
0.2 [0.008] M
0.05 [0.002]

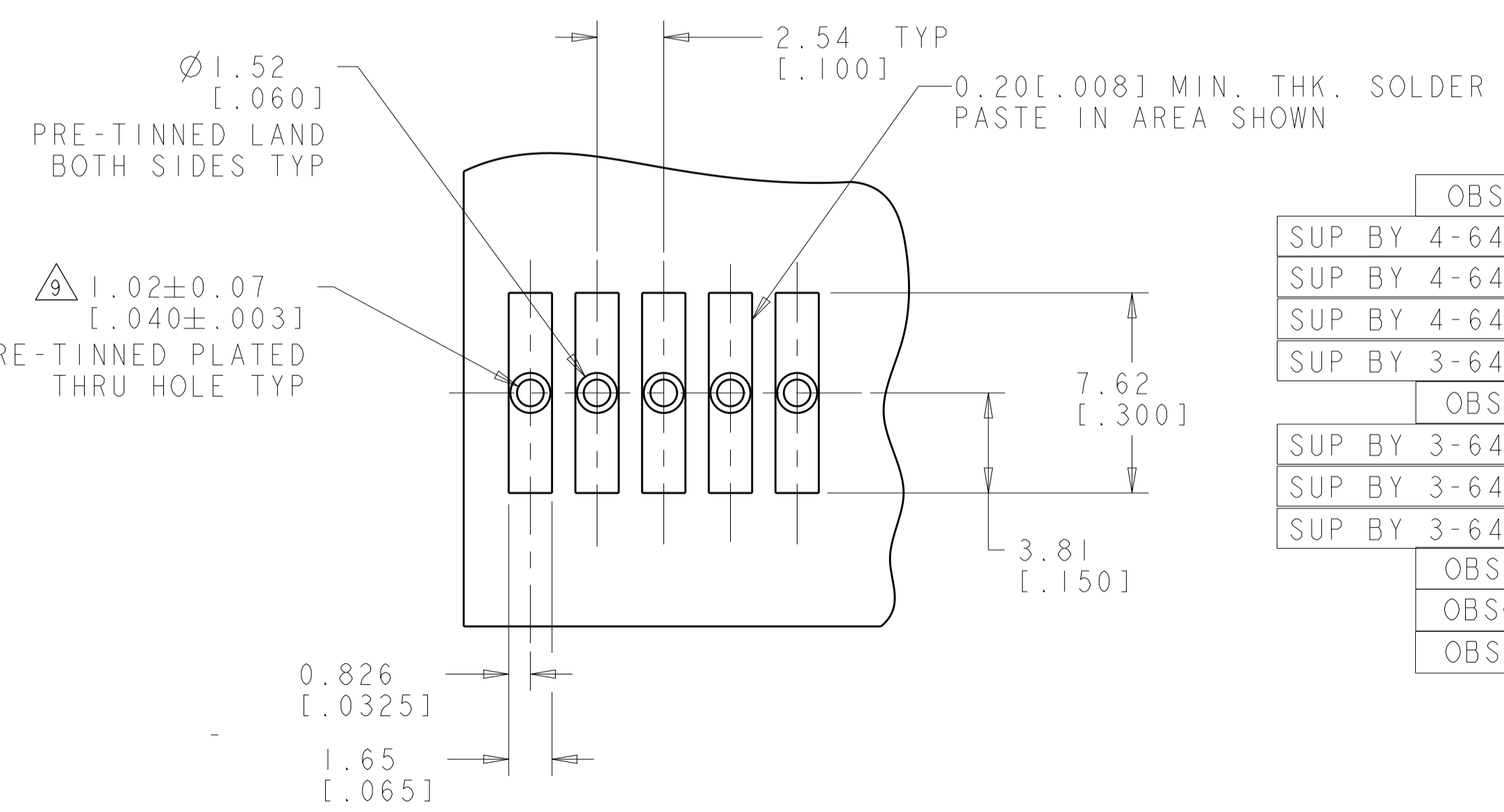

W	G	L	NO OF POSN	PART NO
7.62 [0.300]	12.70 [0.500]	30.48 [1.200]	12	4-647050-2
-	10.16 [0.400]	27.94 [1.100]	11	4-647050-1
-	7.62 [0.300]	25.40 [1.000]	10	4-647050-0
-	5.08 [0.200]	22.86 [0.900]	9	3-647050-9
-	2.54 [0.100]	20.32 [0.800]	8	3-647050-8
-	-	17.78 [0.700]	7	3-647050-7
-	-	15.24 [0.600]	6	3-647050-6
-	-	12.70 [0.500]	5	3-647050-5
-	-	10.16 [0.400]	4	3-647050-4
-	-	7.62 [0.300]	3	3-647050-3
-	-	5.08 [0.200]	2	3-647050-2
OBSOLETE	12.70 [0.500]	17.78 [0.700]	14	1-647050-4
SUP BY 4-647050-2	7.62 [0.300]	12.70 [0.500]	12	1-647050-2
SUP BY 4-647050-1	-	10.16 [0.400]	11	1-647050-1
SUP BY 4-647050-0	-	7.62 [0.300]	10	1-647050-0
SUP BY 3-647050-9	-	5.08 [0.200]	9	647050-9
OBSOLETE	-	2.54 [0.100]	8	647050-8
SUP BY 3-647050-7	-	-	7	647050-7
SUP BY 3-647050-6	-	-	6	647050-6
SUP BY 3-647050-5	-	-	5	647050-5
OBSOLETE	-	-	4	647050-4
OBSOLETE	-	-	3	647050-3
OBSOLETE	-	-	2	647050-2

THIS DRAWING IS A CONTROLLED DOCUMENT.

APVD: D. BOSSI, DT NOV2001

CHK: D. BOSSI, DT NOV2001

OWN: R. WHITAKER, DT NOV2001

NAME: MTA-100 HEADER ASSY, HIGH TEMPERATURE FRICTION LOCK, .025 SQUARE, STRAIGHT POST, TIN OR TIN LEAD

PRODUCT SPEC

APPLICATION SPEC

SIZE: A1, CAGE CODE: 647050, DRAWING NO: 100779, REV: U

SCALE: 7:1, SHEET: 1 OF 1

单击下面可查看定价，库存，交付和生命周期等信息

[>>TE Connectivity\(泰科\)](#)