

2 POS.

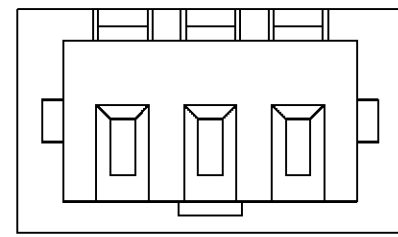

3 POS.

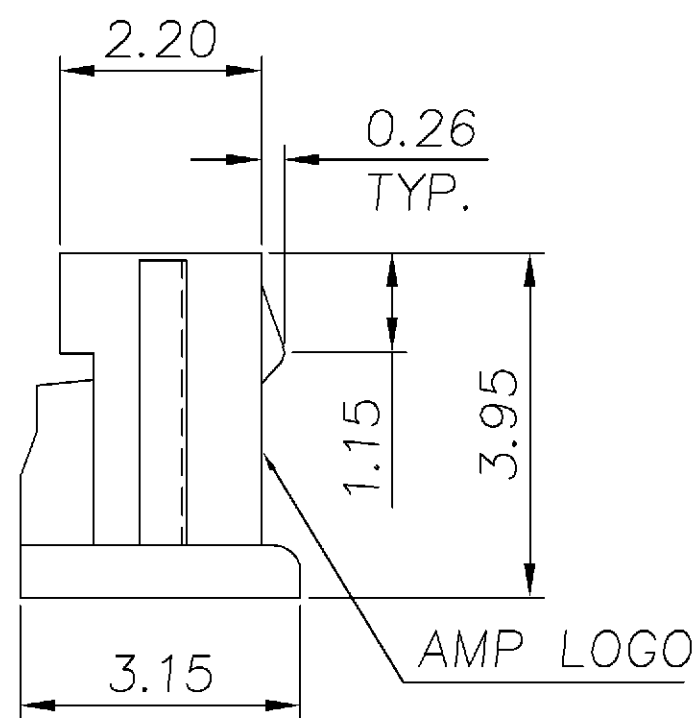

NOTE:  
 1. MATERIAL:  
 HOUSING: THERMOPLASTIC, UL 94V-0,  
 COLOR: NATURAL.  
 2. APPLY TERMINAL PART NO: X-440147-X.

15	20.50	19.20	17.50	1-440146-5
14	19.25	17.95	16.25	1-440146-4
13	18.00	16.70	15.00	1-440146-3
12	16.75	15.45	13.75	1-440146-2
11	15.50	14.20	12.50	1-440146-1
10	14.25	12.95	11.25	1-440146-0
9	13.00	11.70	10.00	440146-9
8	11.75	10.45	8.75	440146-8
7	10.50	9.20	7.50	440146-7
6	9.25	7.95	6.25	440146-6
5	8.00	6.70	5.00	440146-5
4	6.75	5.45	3.75	440146-4
3	5.50	4.20	2.50	440146-3
2	4.25	2.95	1.25	440146-2
POS.	A	B	C	PART NUMBER
	DIMENSIONS			

PRINT DIST DW DIMENSIONS IN MILLIMETERS. DO NOT SCALE PRINT.

B1	REVISION RECORD	ECO	REVISD PER ECO-11-005301	RK HMR 02APR11	DWN CHK DATE
----	-----------------	-----	--------------------------	----------------	--------------

DIMENSION : 0 PLC ± 1 PLC ±0.15 2 PLC ±0.10 3 PLC ±0.05 ANGLES ±3'		DWN O. HU 29-JUL-2003	TE Connectivity	
MATERIAL SEE NOTE		CHK A. WU 29-JUL-2003	NAME	
FINISH SEE NOTE		APVD J. CHENG 29-JUL-2003	WIRE TO BOARD SOCKET, HOUSING, 1.25 PITCH.	
		PRODUCT SPEC 108-57225	LOC DW A <sub>3</sub>	DRAWING NO C-440146
		QUALIFICATION TEST REPORT 501-57229	REV B1	
		WEIGHT	SCALE	SHEET 1 OF 2

NUMBER  
C-440146

METRIC  
3RD ANGLE PROJECTION

METRIC

DIMENSIONS IN MILLIMETERS. DO NOT SCALE PRINT.

PRINT  
DW

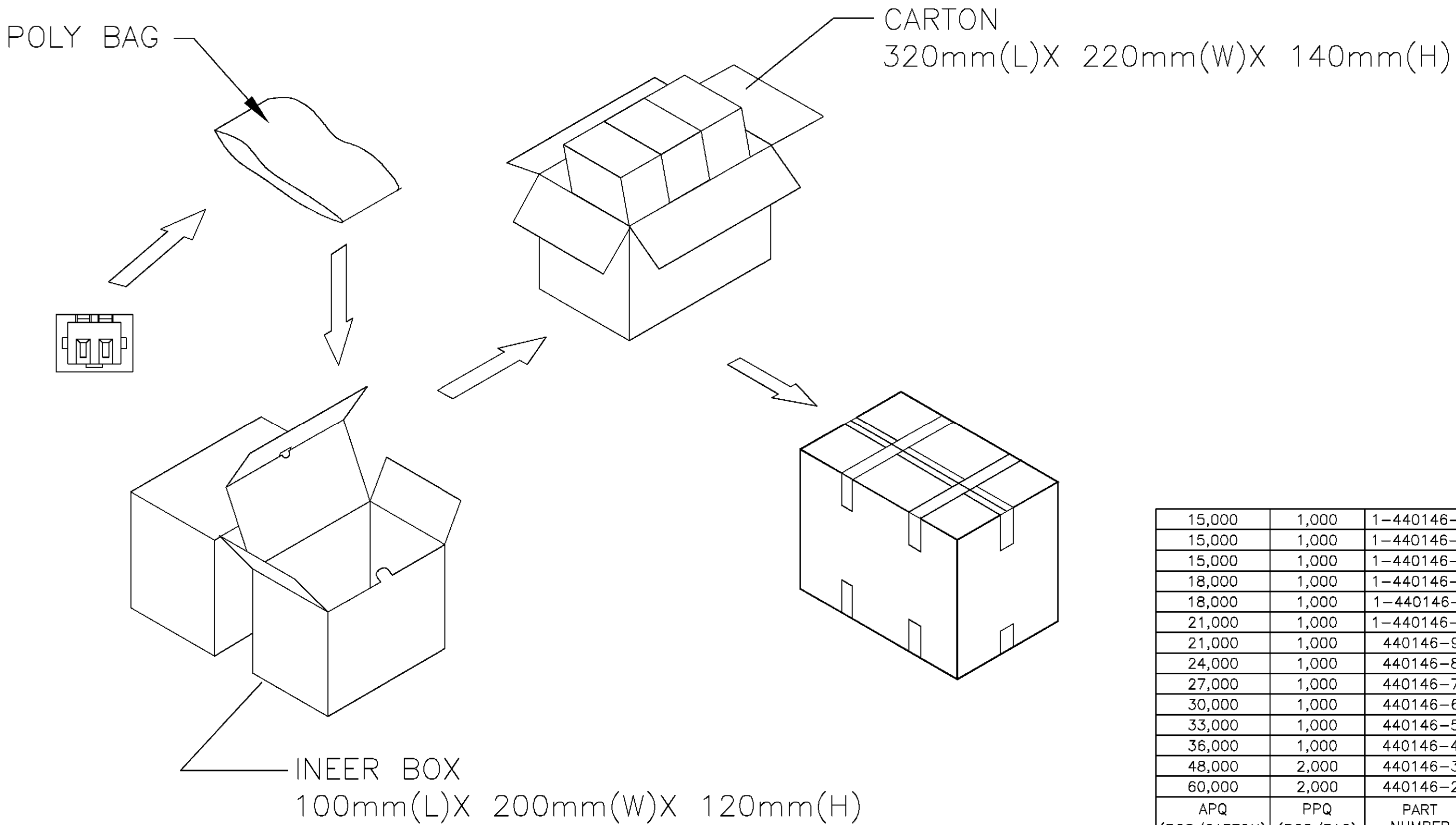

15,000	1,000	1-440146-5
15,000	1,000	1-440146-4
15,000	1,000	1-440146-3
18,000	1,000	1-440146-2
18,000	1,000	1-440146-1
21,000	1,000	1-440146-0
21,000	1,000	440146-9
24,000	1,000	440146-8
27,000	1,000	440146-7
30,000	1,000	440146-6
33,000	1,000	440146-5
36,000	1,000	440146-4
48,000	2,000	440146-3
60,000	2,000	440146-2
APQ (PCS/CARTON)	PPQ (PCS/BAG)	PART NUMBER

DIMENSION : 0 PLC ± 1 PLC ±0.15 2 PLC ±0.10 3 PLC ±0.05 ANGLES ±3'	DWN	O. HU	
	CHK	A. WU	
MATERIAL	APVD	J. CHENG	NAME  WIRE TO BOARD SOCKET, HOUSING, 1.25 PITCH.
	PRODUCT SPEC	29-JUL-2003	
FINISH	QUALIFICATION TEST REPORT	LOC	SIZE
	WEIGHT	DW	DRAWING NO
SEE NOTE	SEE NOTE	A <sub>3</sub>	C-440146
SEE SHEET 1.	ECO	SCALE	REV
LTR	REVISION RECORD	---	B1
DWN	CHK	SHEET	2 OF 2
DATE			

单击下面可查看定价，库存，交付和生命周期等信息

[>>TE Connectivity\(泰科\)](#)