

REVISIONS				
P	LTN	DESCRIPTION	DATE	OWN APVD
A		NEW DRAWING	08APR2019	RS JO

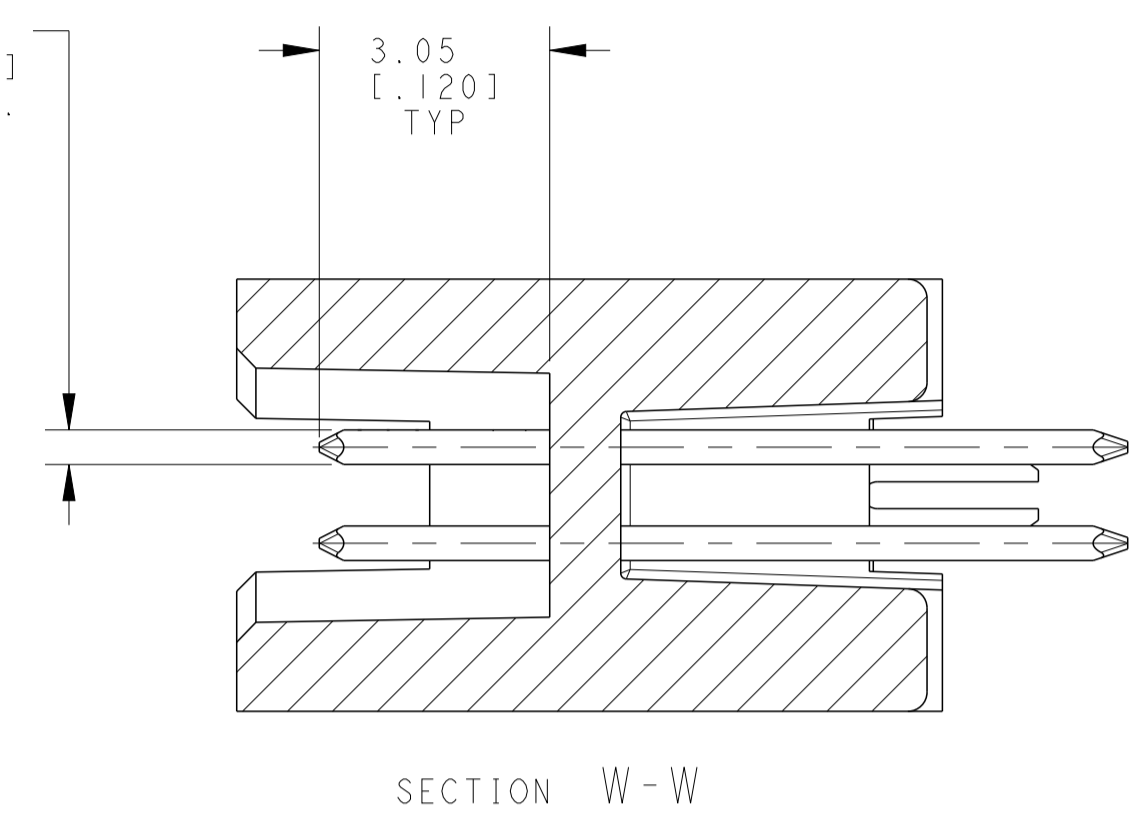

- 1 0.00076[.000030] GOLD AT POINT OF MEASUREMENT, 0.00051[.000020] MIN AT THE END OF AREA G, (LOCALIZED GOLD PLATE AREA), 0.0038[.000150] TIN-LEAD ON LOCALIZED TIN PLATED AREA, ALL OVER 0.0013[.000050] NICKEL
- 2 USE 1.55±0.02[.0610±.0010] DRILLED HOLE (1.5MM DRILL). FINISH TO BE TIN PLATE OVER 0.02[.001] MIN COPPER.
- 3 DIMENSION APPLIES AT BASE OF SHROUD.
- 4 THE NOTED DIMENSIONS APPLY AT THE MATING FACE OF THE HOUSING.
- 5 0.0038 [.000150] TIN LEAD ON HOLD DOWN, ALL OVER 0.0013 [.000050] NICKEL
- 6 DIMENSIONS NOTED APPLY FROM THE BASIC DIMENSION LINE (NOT THE CIRCUIT CAVITY CENTER LINE) TO THE SURFACE INDICATED.
- 7. IF PLANNING TO USE MORE THAN ONE MATING PAIR OF CONNECTORS TO INTERCONNECT 2 BOARDS, PLEASE REFER TO THE SPACING PARAGRAPH IN APPLICATION SPEC, #114-7010.
- 8. PACKAGED IN EIA-481 TAPE AND REEL SEE TABLE FOR DETAILS.
- 9 HOUSING: LCP, COLOR: BLACK.  
POST: PHOSPHOR BRONZE.  
HOLD DOWN: COPPER ALLLOY  
VACUUM COVER: ALUMINIUM
- 10 0.00076[.000030] GOLD AT POINT OF MEASUREMENT, 0.00051[.000020] MIN AT THE END POINTS OF AREA G, (LOCALIZED GOLD PLATE AREA), 0.0038[.000150] TIN ON LOCALIZED TIN PLATED AREA, ALL OVER 0.0013[.000050] NICKEL.
- 11 0.0038[.000150] TIN ON HOLD DOWN, ALL OVER 0.0013 [.000050] NICKEL

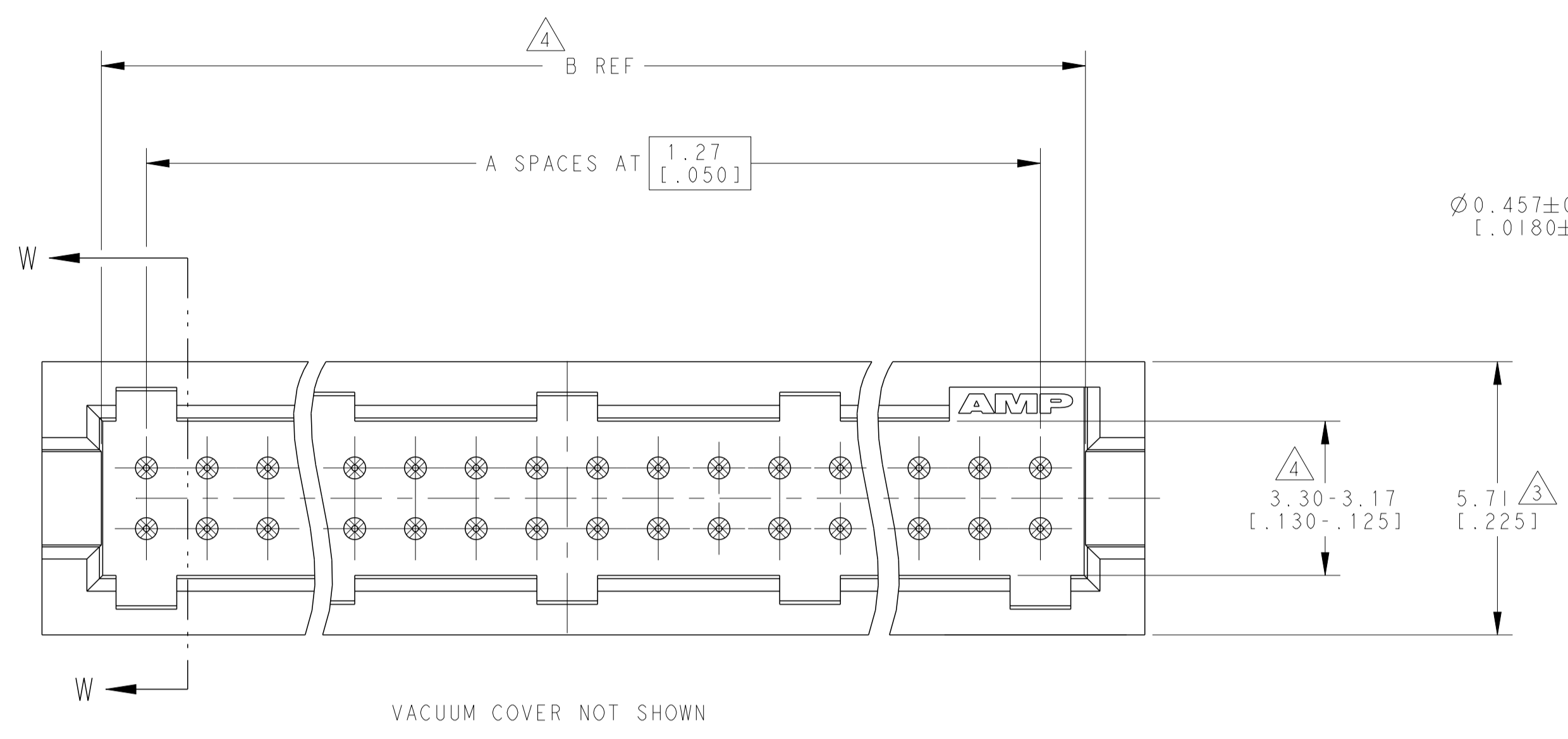
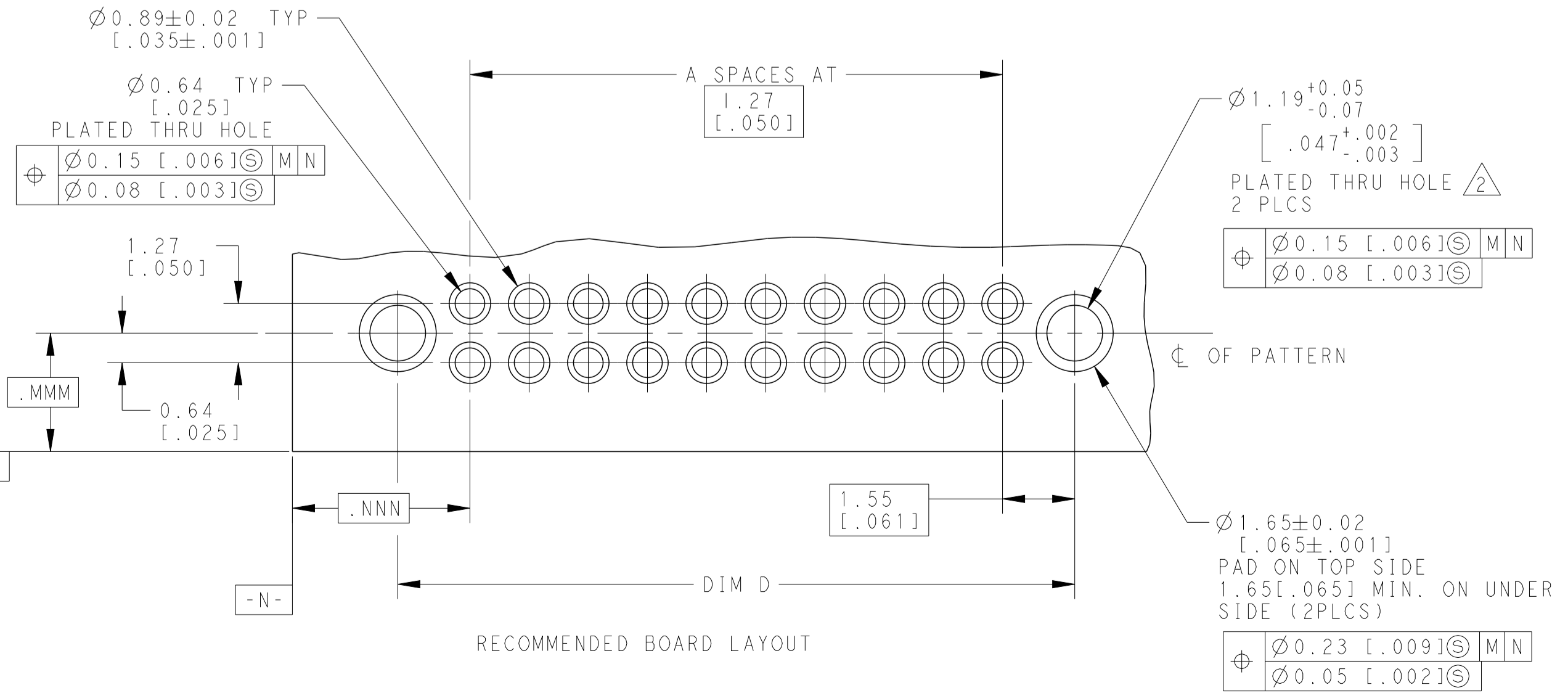
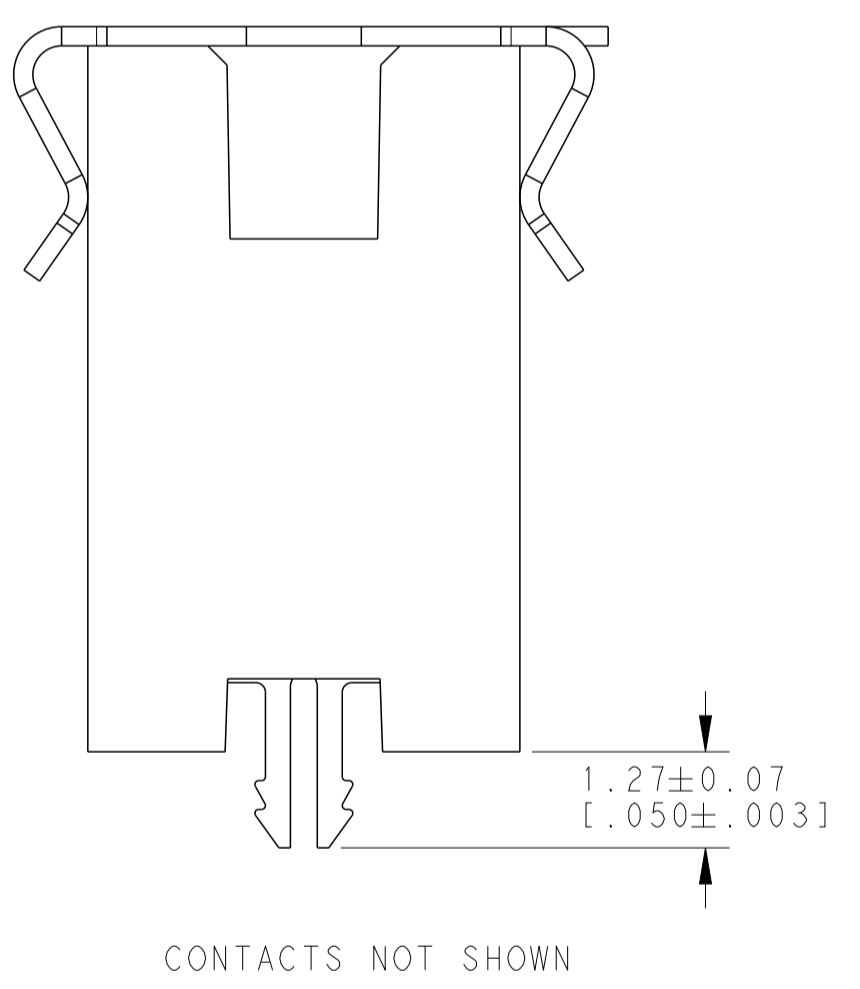
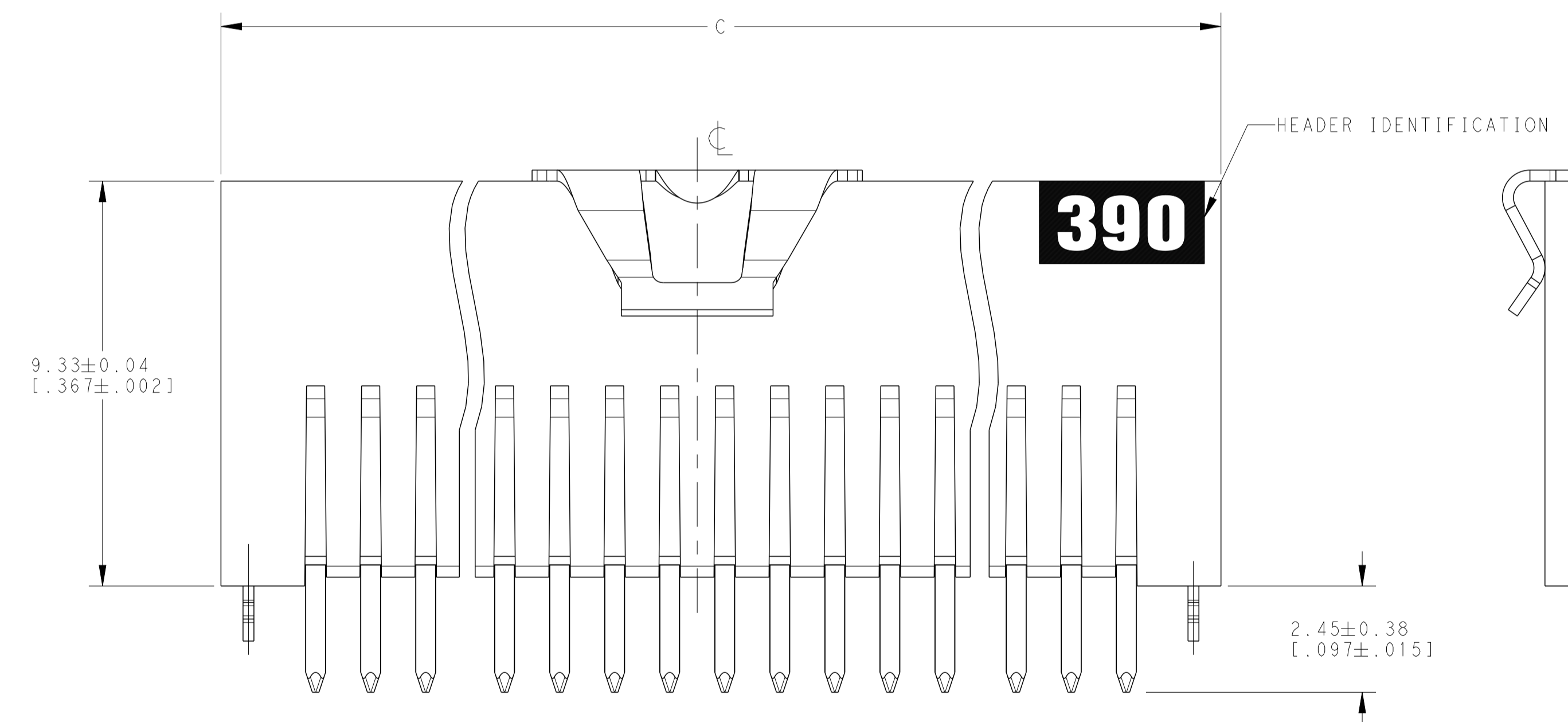

FINISH	TAPE WIDTH	D	C	B	A	NUMBER OF POSITIONS	PART NUMBER
1 10	88 mm	65.33 [2.572]	66.59 [2.622]	64.05 [2.522]	49	100	6-2267260-0
1 10	88 mm	58.978 [2.322]	60.25 [2.372]	57.71 [2.272]	44	90	5-2267260-9
1 10	72 mm	52.63 [2.072]	53.89 [2.122]	51.35 [2.022]	39	80	5-2267260-8
1 10	72 mm	46.28 [1.822]	47.54 [1.872]	45.00 [1.772]	34	70	5-2267260-7
1 10	56 mm	39.93 [1.822]	41.19 [1.622]	38.65 [1.522]	29	60	5-2267260-6
1 10	44 mm	33.58 [1.322]	34.84 [1.372]	32.30 [1.272]	24	50	5-2267260-5
1 10	44 mm	27.23 [1.072]	28.49 [1.122]	25.95 [1.022]	19	40	5-2267260-4
1 10	44 mm	20.88 [1.072]	22.14 [1.072]	19.60 [1.772]	14	30	5-2267260-3
1 10	32 mm	14.53 [1.572]	15.79 [1.622]	13.25 [1.522]	9	20	5-2267260-2
1 10	32 mm	8.18 [1.322]	9.44 [1.372]	6.90 [1.272]	4	10	5-2267260-1
1 5	88 mm	65.33 [2.572]	66.59 [2.622]	64.05 [2.522]	49	100	1-2267260-0
1 5	88 mm	58.978 [2.322]	60.25 [2.372]	57.71 [2.272]	44	90	2267260-9
1 5	72 mm	52.63 [2.072]	53.89 [2.122]	51.35 [2.022]	39	80	2267260-8
1 5	72 mm	46.28 [1.822]	47.54 [1.872]	45.00 [1.772]	34	70	2267260-7
1 5	56 mm	39.93 [1.572]	41.19 [1.622]	38.65 [1.522]	29	60	2267260-6
1 5	44 mm	33.58 [1.322]	34.84 [1.372]	32.30 [1.272]	24	50	2267260-5
1 5	44 mm	27.23 [1.072]	28.49 [1.122]	25.95 [1.022]	19	40	2267260-4
1 5	44 mm	20.88 [1.072]	22.14 [1.072]	19.60 [1.772]	14	30	2267260-3
1 5	32 mm	14.53 [1.572]	15.79 [1.622]	13.25 [1.522]	9	20	2267260-2
1 5	32 mm	8.18 [1.322]	9.44 [1.372]	6.90 [1.272]	4	10	2267260-1

THIS DRAWING IS A CONTROLLED DOCUMENT. DWN: RAVLS 08APR2019  
CHK: J. OLSON 08APR2019

DIMENSIONS: mm [INCH] TOLERANCES UNLESS OTHERWISE SPECIFIED:  
0 PLC ±.013 [.005]  
1 PLC ±.013 [.005]  
2 PLC ±.013 [.005]  
3 PLC ±.013 [.005]  
4 PLC ±.013 [.005]  
ANGLES ±.013 [.005]

MATERIAL: SEE TABLE FINISH: SEE TABLE

NAME: HDR ASSY, THROUGH HOLE (9.90[.390] MATED HEIGHT) AMPMODU 50/50 GRID  
CAGE CODE: 114-7010  
DRAWING NO: 108-1332  
APPLICATION SPEC: 114-7010  
WEIGHT: -

SCALE: 10:1 SHEET 1 OF 1 REV A

单击下面可查看定价，库存，交付和生命周期等信息

[>>TE Connectivity\(泰科\)](#)