

PART NUMBER	REV	DESCRIPTION
2305750-1	A	APPLICATOR W/ SPECIALIZED TERMINATOR
2305750-2	A	APPLICATOR W/ SPECIALIZED TERMINATOR W/ COM
2305750-3	A	APPLICATOR ONLY
7-2305750-7	A	CRIMP TOOLING KIT

APPLICATOR DATA		
CRIMP WIRE	SIZE	TYPE
2.794 mm [0.110]	F	
APPLICATOR INSTRUCTIONS 408-35046		

TERMINAL DATA: TE TERMINAL		TE CRIMP SPECIFICATION	
TERMINAL NAME: (AMPLIVAR) PIG-TAIL SPLICE			
LEAD WIRE STRIP LENGTH		INSULATION DIAMETER RANGE	
7.09-8.66mm [0.279-0.341 IN]		Ø -	
TERMINAL APPLICATION SPECIFICATION (A) 114-2002		-	
TERMINAL APPLICATION SPECIFICATION (B) 114-2003		-	
TERMINALS APPLIED			
TE TERMINAL	TE TERMINAL	TE TERMINAL	TE TERMINAL
(A) 62040-1	(A) 62040-2	(B) 62306-1	(B) 62306-2
(B) 62307-2	(B) 62307-3	-	-
-	-	-	-

WIRE SIZE	CRIMP HEIGHT mm [INCH]	CRIMP HEIGHT REFERENCE SETTING
5000 CMA [MAX]	2.06±0.05mm [0.081±0.002 IN] REF	10.3
1500 CMA [MIN]	1.60±0.05mm [0.063±0.002 IN] REF	5.5

- 1 RECOMMENDED SPARE PARTS
- 2 REFER TO SUPPLIED INSTRUCTION SHEET FOR CLEANING, LUBRICATION & STORAGE OF APPLICATOR.
- 3 APPLY PART NUMBER 1-23419-5 LOCTITE TO THREADS OF ITEM 248.
- 4 CRIMP HEIGHT REFERENCE SETTING WAS THE SETTING USED WHEN THE APPLICATOR WAS QUALIFIED AT THE FACTORY. ADJUSTMENT MAY BE NECESSARY WHEN RUNNING APPLICATOR IN THE FIELD.
- 5. UNLESS OTHERWISE SPECIFIED TORQUE VALUES SHALL BE USED PER DOCUMENT 101-35000
- 6 ITEM NOT SHOWN
- 7 GREASE BEARING SURFACES LIGHTLY.

**\*WARNING**  
 ON INSTALLATION, SET WIRE DISC TO CRIMP HEIGHT REFERENCE SETTING FOR LARGEST WIRE SIZE. CRIMP HEIGHT REFERENCE SETTINGS GREATER THAN THE VALUE SHOWN MAY CAUSE DAMAGE TO THE CRIMP TOOLING. REFER TO THE INSTRUCTION SHEET FOR PROPER SETUP AND ADJUSTMENTS.

- 8 GREASE THREADS AND GROOVE OF ITEM 35 AND O-RING, ITEM 252.
- 9 APPLY GREASE FILLING IN VOIDS/CAVITIES OF DETENT PLATE, ITEM 249.
- 10 MAGNET, ITEM 166, MUST BE ORIENTED CORRECTLY IN ORDER TO PROPERLY ACTUATE THE COUNTER.
- 11 REFER TO TERMINAL CUSTOMER DRAWING FOR CRIMP HEIGHT FORMULA TO CALCULATE SPECIFIC CRIMP HEIGHTS.
- 12 INCLUDE A COPY OF THIS APPLICATOR LOG SHEET WITH THE DOCUMENTATION PACKAGE, ITEM 71.

1	-	REF	1	-	-	2326540-3	TERMINATOR, 5K CE W/ COM, MODIFIED, PIG-TAIL SPLICE	263
1	-	0.2	2.2	2.2	-	2030758-3	TUBING, POLYURETHANE, 6mm	262
1	-	REF	-	-	-	2325997-1	GUARD INSERT, PIG-TAIL SPLICE	261
1	-	REF	-	1	-	2326540-1	TERMINATOR, 5K CE, MODIFIED, PIG-TAIL SPLICE	260
1	-	1	1	1	-	8-21084-0	O-RING, .676 ID, .070 DIA. MAT.	252
1	-	3	3	3	-	1-1655784-6	SCR, FLT SKT HD CAP, M3 X 6	250
1	-	1	1	1	-	2844969-1	DETENT PLATE	249
1	-	1	1	1	-	7-1655316-0	SCR, SKT HD CAP, M8 X 25.0	248
1	-	1	1	1	-	2844970-1	DETENT PIN	247
1	-	1	1	1	-	2-22279-6	SPRING, COMPRESSION	246
1	-	2	2	2	-	1655316-9	SCR, SKT HD CAP, M2.5 X 12.0	215
1	-	1	1	1	-	3-22287-6	SPRING, EXTENSION	212
1	-	1	1	1	-	2079253-2	POST, TENSION SPRING, HOLE, WIDTH ACROSS FLATS	211
1	-	1	1	1	-	1900626-3	COLLAR, SHAFT, SET SCREW STYLE	210
1	-	1	1	1	-	2325331-1	CAM FOLLOWER, MINIATURE, HEAVY LOAD	206
1	-	1	1	1	-	2325328-1	BOLT, ADJUSTING, HEX SOCKET, HEX HEAD	205
1	-	1	1	1	-	1-992976-0	VALVE, SPEED CONTROLLER	203
1	-	1	1	1	-	2305726-1	TONK, GUILLOTINE	201
1	-	1	1	1	-	2305725-1	RETAINER, TONK	200
1	-	1	1	1	-	1655316-1	SCR, SKT HD CAP, M2 X 6.0	199
1	-	2	2	2	-	1-18032-2	SCR, SET, FLT PNT, M8 X 8.0	198
1	-	2	2	2	-	5-1655316-2	SCR, SKT HD CAP, M5 X 6.0	197
1	-	2	2	2	-	1-18028-3	WASHER, FLAT, REG M5	196
1	-	4	4	4	-	1-1655316-8	SCR, SKT HD CAP, M4 X 6.0	195
-77	-3	-2	-1	U/M		PART NO	DESCRIPTION	ITEM NO

1	-	1	1	1	-	2326296-1	AIR NOZZLE, MODIFIED	182
1	-	1	1	1	-	2305724	BLADE, GUILLOTINE	181
1	-	1	1	1	-	2305723-1	MOUNT, GUILLOTINE	180
1	-	1	1	1	-	4-992946-5	PIN, DOWEL 5 X 18	179
1	-	2	2	2	-	2-1655316-6	SCR, SKT HD CAP, M4 X 20.0	178
1	-	2	2	2	-	21045-3	RING, RETAIN, EXTERN, 3/16 CRESCENT	172
1	-	1	1	1	-	994969-1	MAGNET, RARE EARTH, HIGH ENERGY	166
1	-	REF	REF	REF	-	994970-2	COUNTER, MAGNETIC	164
1	-	1	1	1	-	240638-1	SPRING, FEED FINGER	163
1	-	1	1	1	-	2305752-1	FEED ARM	142
1	-	1	1	1	-	3-23627-7	PIN, RETAIN, GRVD, 3/16 X .854	137
1	-	1	1	1	-	2280548-1	HOLDER, FEED FINGER	136
1	-	4	4	4	-	2079160-3	SPRING PLUNGER, M4	115
1	-	4	4	4	-	2079844-1	SPRING PLUNGER, M4	110
1	-	1	1	1	-	2217397-1	WHEEL, ADJUST	109
1	-	2	2	2	-	992976-7	VALVE, SPEED CONTROLLER	108
1	-	1	1	1	-	2119454-1	KNOB, FEED ADJUST	106
1	-	1	1	1	-	2280501-1	GUIDE, FEED ARM	105
1	-	1	1	1	-	2325229-1	TEE, PLUG-IN	104
1	-	1	1	1	-	2256823-2	CYLINDER, AIR, DOUBLE ACTING, COMPACT	103
1	-	2	2	2	-	2280416-1	ROD END, CYLINDER	102
1	-	8	8	8	-	5-1655316-7	SCR, SKT HD CAP, M5 X 25.0	101
1	-	1	1	1	-	992946-2	PIN, DOWEL 3 X 16	100
1	-	1	1	1	-	3-18031-7	SCR, SET, CUP POINT M6 X 4.0	99
1	-	1	1	1	-	2-22279-9	SPRING, COMPRESSION	98
1	-	1	1	1	-	2280506-1	LEVER, TERMINAL SUPPORT	97
1	-	1	1	1	-	5-1655316-4	SCR, SKT HD CAP, M5 X 12.0	96
1	-	5	5	5	-	2-2168083-0	SCR, SKT HD CAP, RoHS, M5 X 12	95
1	-	1	1	1	-	2305749-1	MOUNT, TERMINAL SUPPORT LEVER	95
1	-	1	1	1	-	2305715-1	GUIDE, TERMINAL TRANSFER	85
1	-	1	1	1	-	2305714-1	GUIDE, TERMINAL TRANSFER	84
1	-	1	1	1	-	6-1655316-0	SCR, SKT HD CAP, M5 X 40.0	82
1	-	1	1	1	-	1-22281-8	SPRING, COMPRESSION	81
1	-	1	1	1	-	2326541-1	DOCUMENTATION PACKAGE	71
1	-	1	1	1	-	2119740-1	TAG, IDENTIFICATION	67
1	-	2	2	2	-	2168078-1	SCREW, DRIVE, RH, RoHS, 2 x .188	66
1	-	1	1	1	-	2280106-1	FINGER, FEED	56
1	-	4	4	4	-	2079383-4	SCR, BHSC, RoHS (M4 X 8)	54
1	-	1	1	1	-	2280396-1	RETAINER, UPPER TOOLING	52
1	-	2	2	2	-	5-22280-5	SPRING, COMPRESSION	50
1	-	1	1	1	-	4-2119656-0	APPLICATOR BASIC ASSEMBLY, SF	46
1	-	1	1	1	-	2326441-1	RAM, ATLANTIC STYLE, INVERTED SPLICE	44
1	-	8	8	8	-	1-1655316-9	SCR, SKT HD CAP, M4 X 8.0	41
1	-	1	1	1	-	2844968-1	DISC, NUMBERED FA WIRE ADJUSTMENT	40
1	-	1	1	1	-	2844967-1	FA HEAD, ATLANTIC STYLE	37
1	-	1	1	1	-	2844971-1	BOLT, ADJUSTMENT	35
1	-	2	2	2	-	2280415-1	MOUNT, CYLINDER	32
1	-	1	1	1	-	2305748-1	MOUNT, STRIP GUIDE	30
1	-	2	2	2	-	18032-7	SCR, SET, FLT PNT, M5 X 12.0	29
1	-	2	2	2	-	2-18032-5	SCR, SET, FLT PNT, M5 X 20.0	28
1	-	2	2	2	-	22283-1	SPRING, COMPRESSION	27
1	-	1	1	1	-	2280503-1	LEVER, DRAG RELEASE	26
1	-	1	1	1	-	2280502-9	DRAG, TERMINAL	25
1	-	1	1	1	-	2305713-1	STRIP GUIDE, TERMINAL	24
1	-	1	1	1	-	980371-4	SCR, SKT HD SHLDR 5.0 DIA X 6.0	23
1	-	1	1	1	-	2305712-1	SHEAR BLADE	9
1	-	1	1	1	-	2305716-1	DRIVE BAR	8
1	-	1	1	1	-	2305717-1	CRIMPER	1
-77	-3	-2	-1	U/M		PART NO	DESCRIPTION	ITEM NO

REVISIONS				
REV	LTN	DESCRIPTION	DATE	OWN
A		RELEASED	26 JUL 2018	BW

THIS DRAWING IS A CONTROLLED DOCUMENT. OWN: B. WEAVER 25 JUL 2018. CHG: T. BACKENSTOES 25 JUL 2018. APVD: T. BACKENSTOES 25 JUL 2018. DIMENSIONS: mm. TOLERANCES UNLESS OTHERWISE SPECIFIED: 0 PLC ±, 1 PLC ±, 2 PLC ±, 3 PLC ±, 4 PLC ±, ANGLES ±. MATERIAL: FINISH: WEIGHT: SIZE: CAGE CODE: DRAWING NO: RESTRICTED TO: A100779C=2305750. CUSTOMER ACCESSIBLE PRODUCTION DRAWING. SCALE: 3:4. SHEET 1 OF 2. REV A.

REVISIONS				
P.	LTN	DESCRIPTION	DATE	APPV
		SEE SHEET 1		

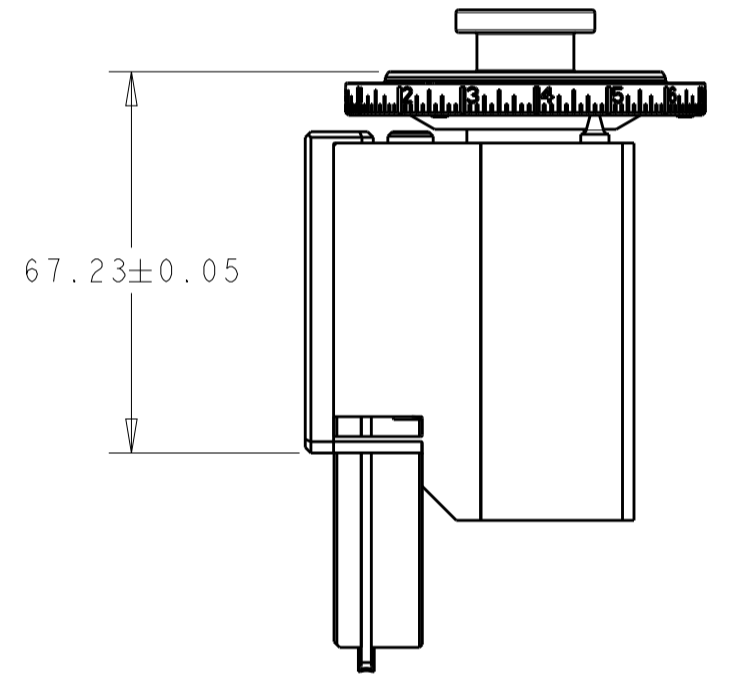
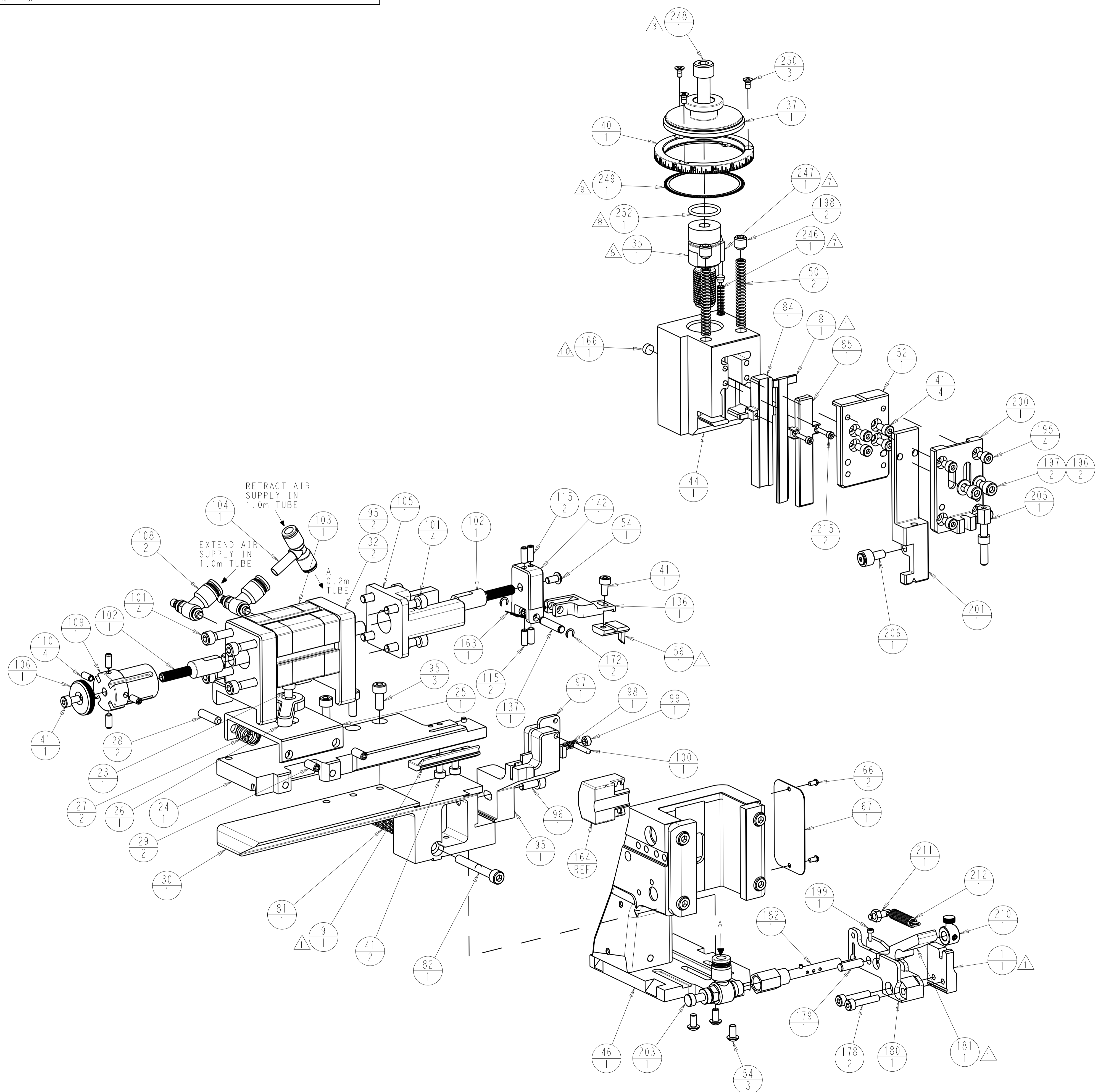

RAM FINE ADJUST SETUP

THIS DRAWING IS A CONTROLLED DOCUMENT.		DWN: B. WEAVER 25 JUL 2018 CHK: T. BACKENSTOES 25 JUL 2018 APPV: T. BACKENSTOES 25 JUL 2018	TE Connectivity		
DIMENSIONS: mm 		TOLERANCES UNLESS OTHERWISE SPECIFIED: 0 PLC ± 1 PLC ± 2 PLC ± 3 PLC ± 4 PLC ± ANGLES ±	NAME: INVERTED PIG-TAIL SPLICE APPLICATOR PRODUCT SPEC: - APPLICATION SPEC: - SIZE: A100779 CAGE CODE: C=2305750 DRAWING NO: - RESTRICTED TO: -		
MATERIAL: -		FINISH: -	WEIGHT: -	CUSTOMER ACCESSIBLE PRODUCTION DRAWING SCALE: 3:4 SHEET 2 OF 2 REV A	

单击下面可查看定价，库存，交付和生命周期等信息

[>>TE Connectivity\(泰科\)](#)