

P	LTR	DESCRIPTION	DATE	DWN	APVD
	F1	REV PER ECR 09-016980	03AUG09	JR	TM
	F2	REVISED PER ECO-17-014333	11OCT2017	RS	DR

AMP WIRE RANGE
2/0 AWG STRANDED

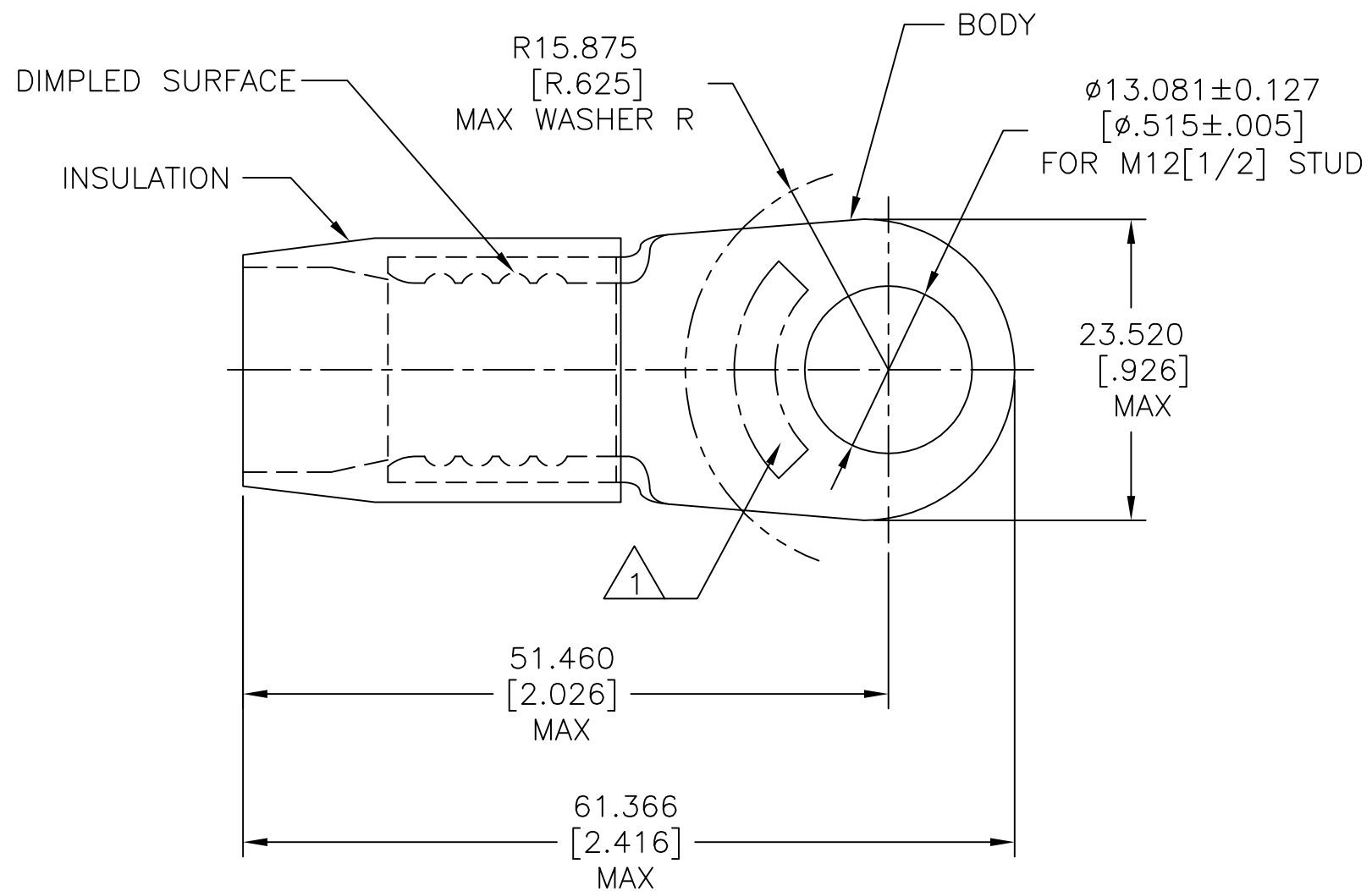

- 1 STAMP AMP 2/0 W*, LOCATE APPROX AS SHOWN.
- 2 BODY MATERIAL THK 2.032±0.051 [.080±.002]
- 3 WIRE INSULATION Ø15.494 [Ø.610] MAX.
- 4 BODY: COPPER PER ASTM B-152
INSULATION: NYLON ASTM D4066 TYPE I.
- 5 BODY: TIN PLATED PER ASTM B-545
INSULATION: COLOR-YELLOW.

MS25036-137 CLASS 2	50	LOOSE PC	324085
MILITARY P/N AND CLASS	QTY	PACKAGE TYPE	PART NO

MAX RECOMMENDED OPERATING TEMPERATURE: 105°C[221°F]	THIS DRAWING IS A CONTROLLED DOCUMENT.	DWN S.S. GOULDEN 9-28-93	STE TE Connectivity				
VOLTAGE RATING: -		CHK R. HERSEY 9-28-93					
CIRCULAR MIL AREA: 60.6-76.3mm ² [119,500-150,500] STRANDED		DIMENSIONS: mm [INCHES]	TOLERANCES UNLESS OTHERWISE SPECIFIED: 0 PLC ± - 1 PLC ± - 2 PLC ± - 3 PLC ± 0.127[.005] 4 PLC ± - ANGLES ± -	APVD M ELLIS 9-28-93	NAME TERMINAL, RING TONGUE, PLASTI-GRIP, WIRE SIZE: 2/0 AWG		
	MATERIAL 4	FINISH 5	PRODUCT SPEC SAE AS7928	SIZE A3	CAGE CODE 00779	DRAWING NO C-324085	RESTRICTED TO -
			APPLICATION SPEC -	SCALE NTS	SHEET 1 OF 1	REV F2	
			WEIGHT -	CUSTOMER DRAWING			

单击下面可查看定价，库存，交付和生命周期等信息

[>>TE Connectivity\(泰科\)](#)