

LOC	DIST	REVISIONS					
GP	00	#	LYR	DESCRIPTION	DATE	OWN	APVD
		C		REVISED PER ECR-19-008054	22MAY2019	IT	SH
		C1		ADD PN 2-4	27AUG2019	IT	SH
		C2		ADD PN 1-3 WITH 1.25MM TAILS	15JUN2020	IT	SH
		C3		ADD PN 3-2 PER ECN-21-106888	17MAY2021	SZ	SZ

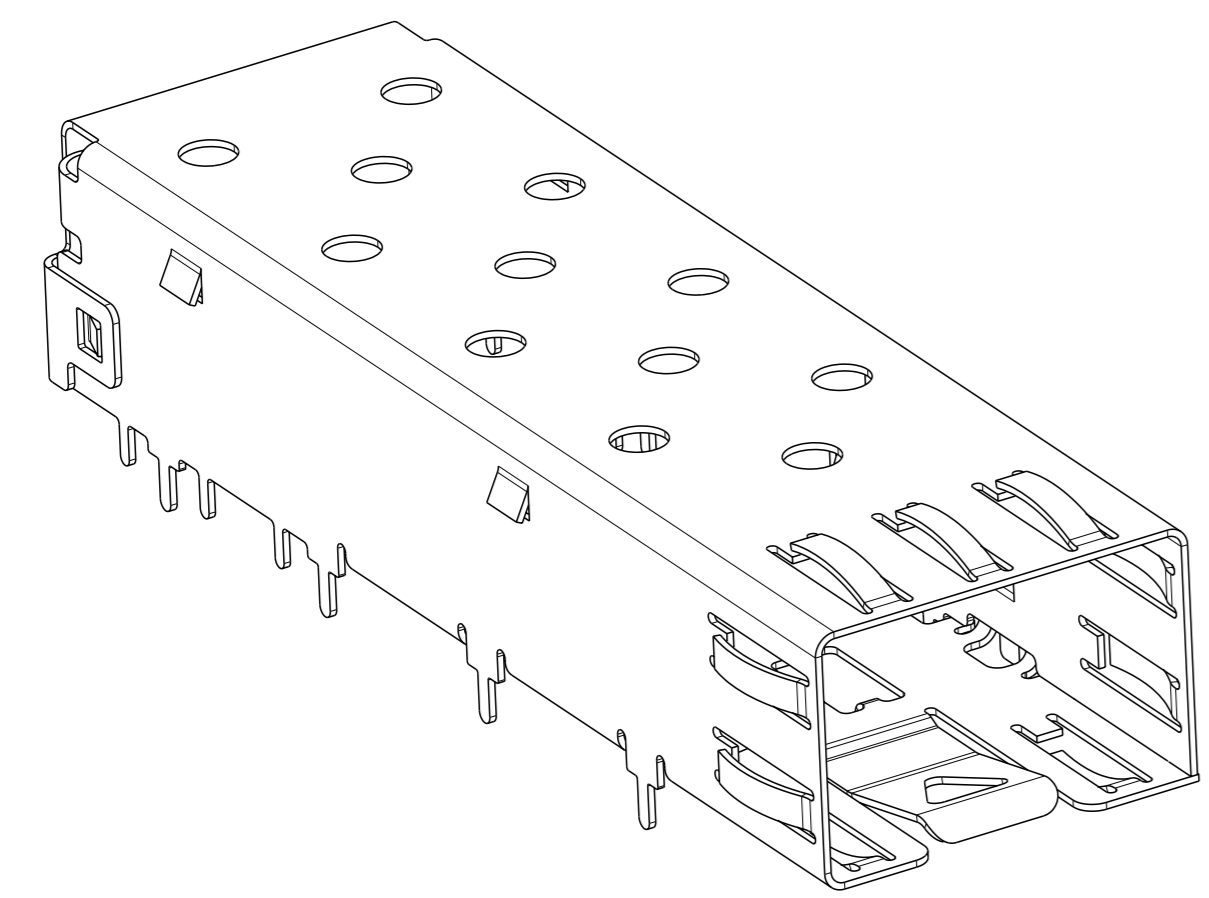

2227303-1, -2, -3, -7  
 1-2227303-2/3

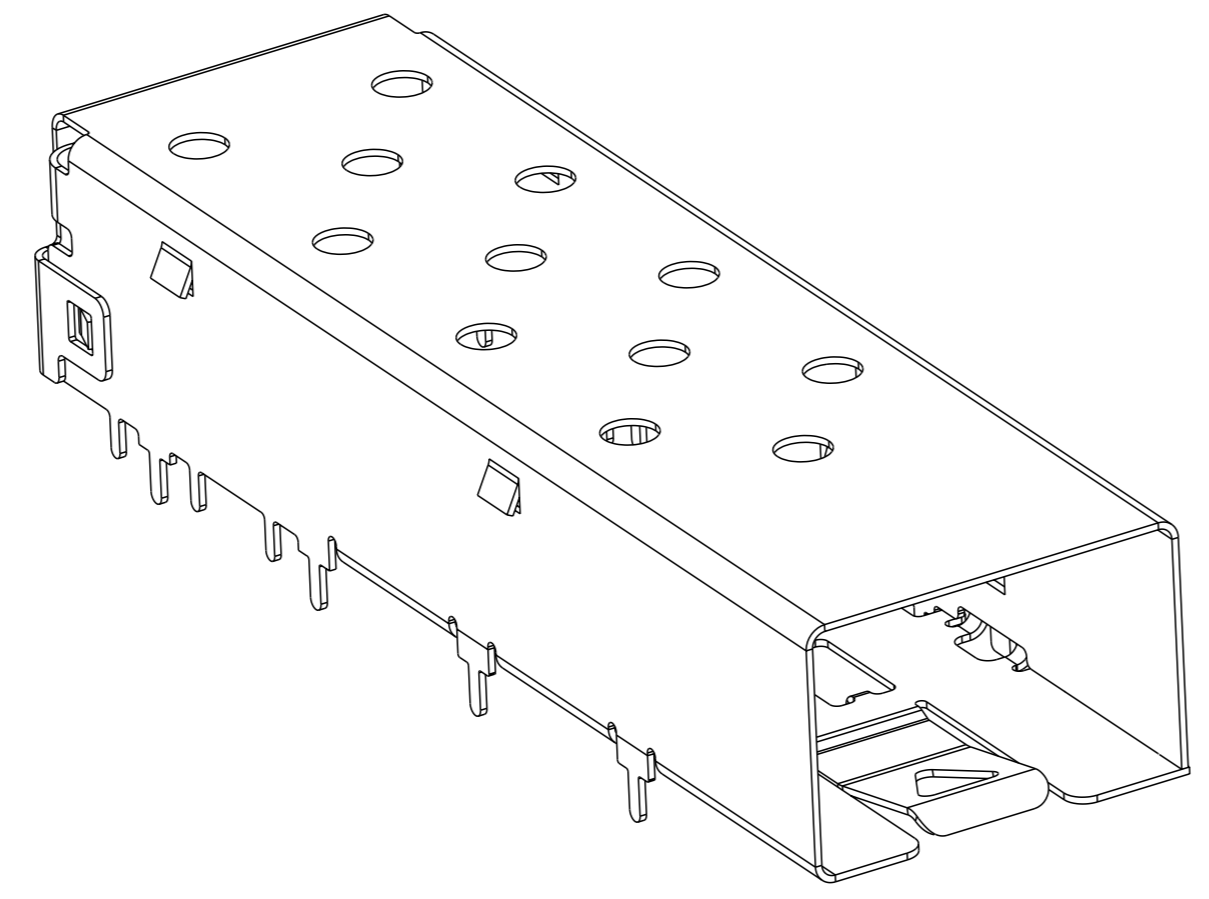

3-2227303-2

- △ MATERIAL: 0.25mm THICK STAINLESS STEEL.
- △ FINISH: 0.00125mm Min. NICKEL OVER ALL , 0.002mm Min. TIN DIPPED ON SOLDER TABS, NON PLATED EDGES PERMISSIBLE.
- 3. MATES WITH SFP MSA COMPLIANT TRANSCEIVERS.
- △ PADS AND VIAS CHASSIS GROUND.
- △ DATUM AND BASIC DIMENSION ESTABLISHED BY CUSTOMER.
- 6. MINIMUM PC BOARD THICKNESS:  
 SINGLE SIDED = 1.50 mm
- △ REFERENCE APPLICATION SPEC. 114-13120, HOLE A, FOR RECOMMENDED DRILL HOLE DIAMETER AND PLATING THICKNESS.
- △ REFERENCE APPLICATION SPEC. 114-13120, HOLE C, FOR RECOMMENDED DRILL HOLE DIAMETER AND PLATING THICKNESS.
- △ ESD PROTECTION PACKAGE.
- △ WITHOUT THREE LOCATION PINS
- △ WITHOUT EMI SPRING
- △ WITH CUSTOMIZED HEATSINK OPEN
- △ PRELIMINARY PART

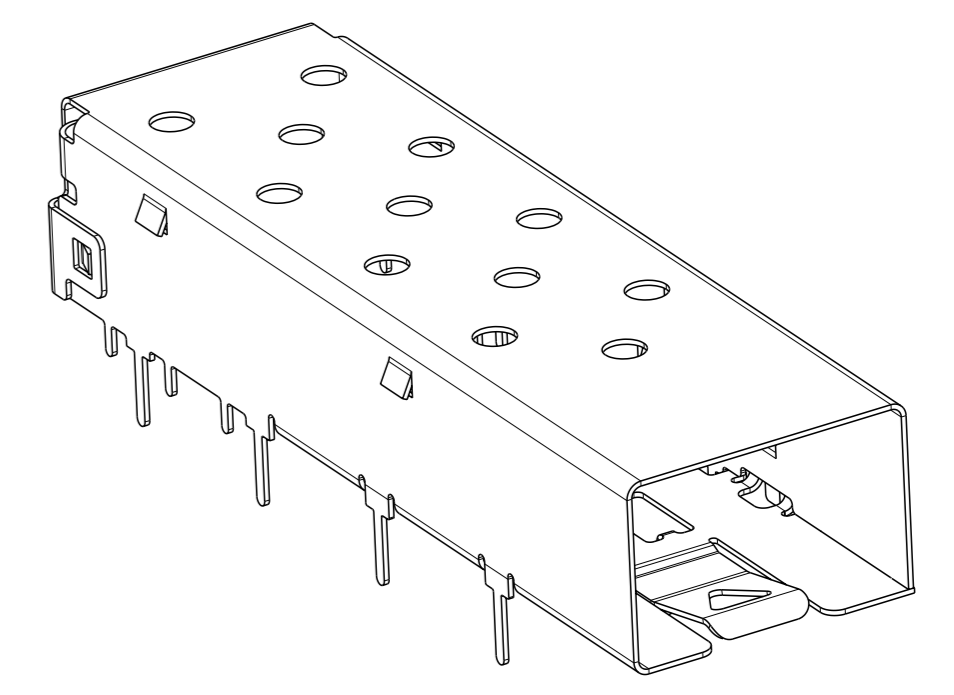

1-2227303-1

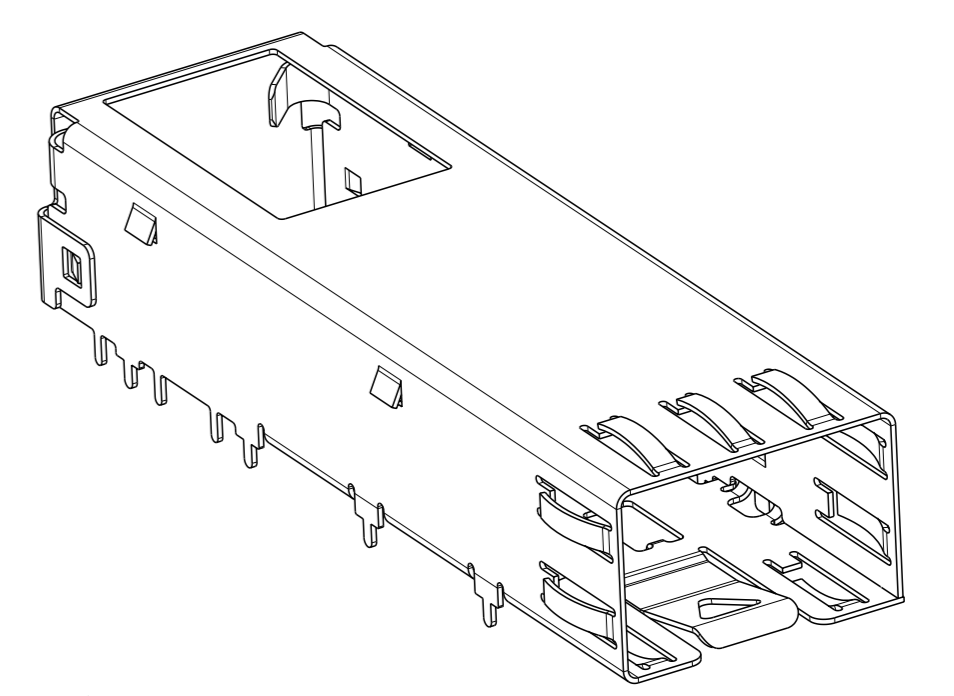
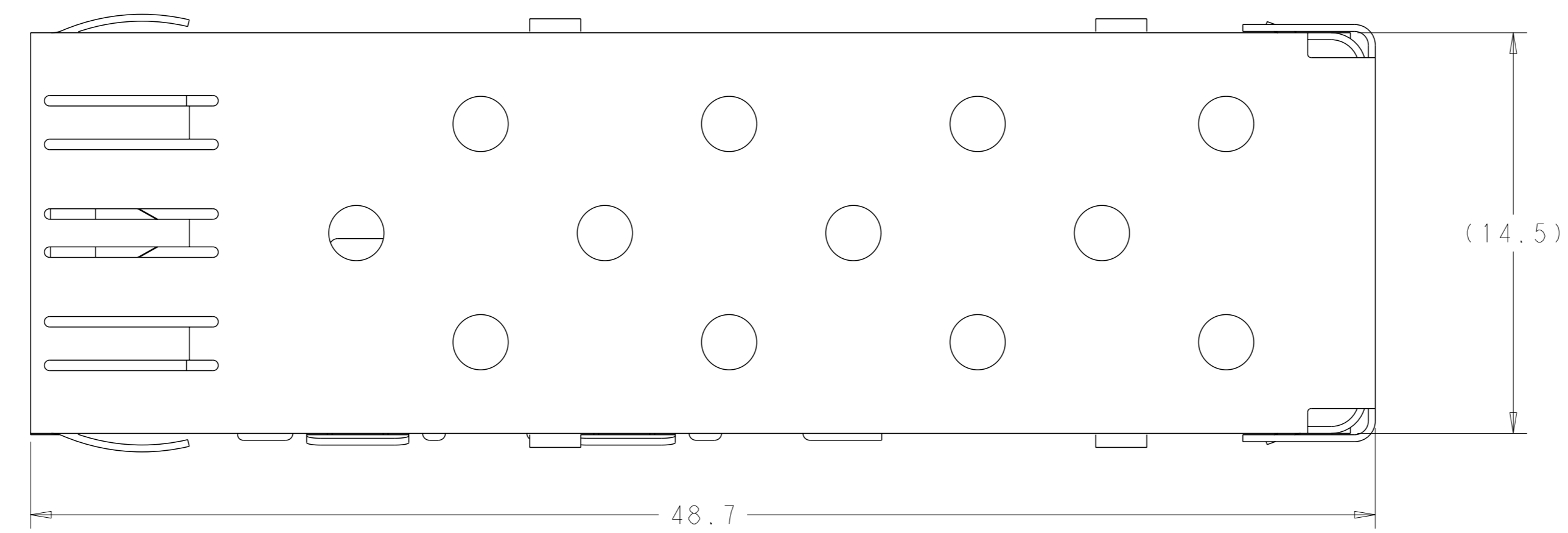

2-2227303-2, 2-2227303-4

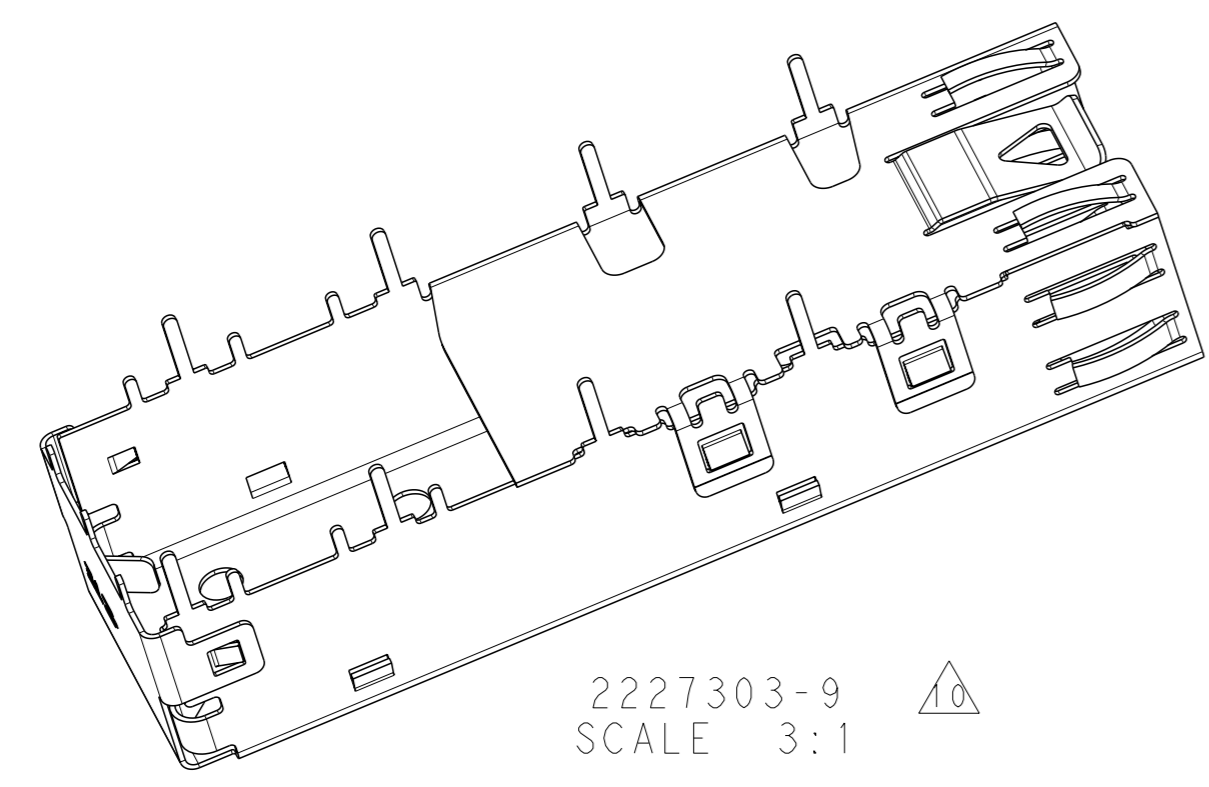
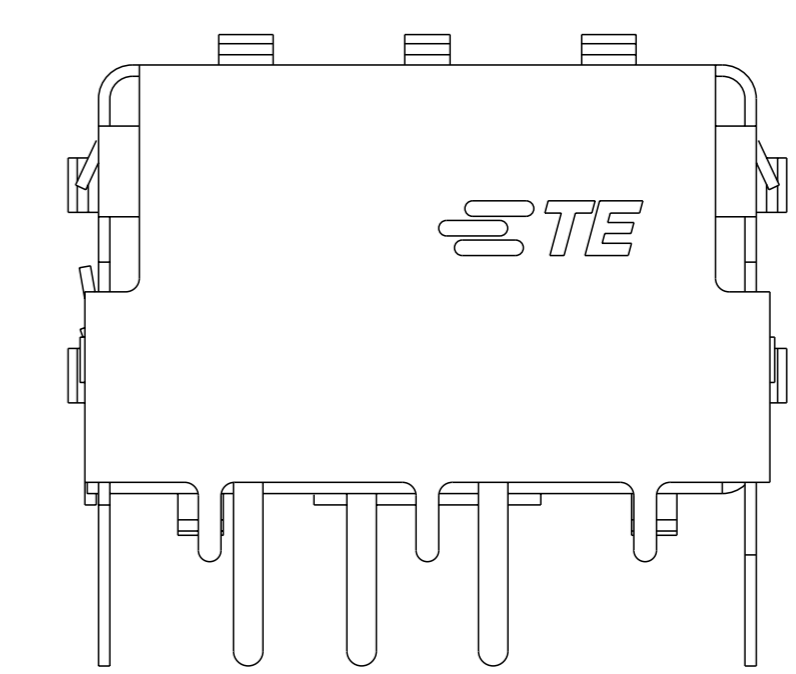
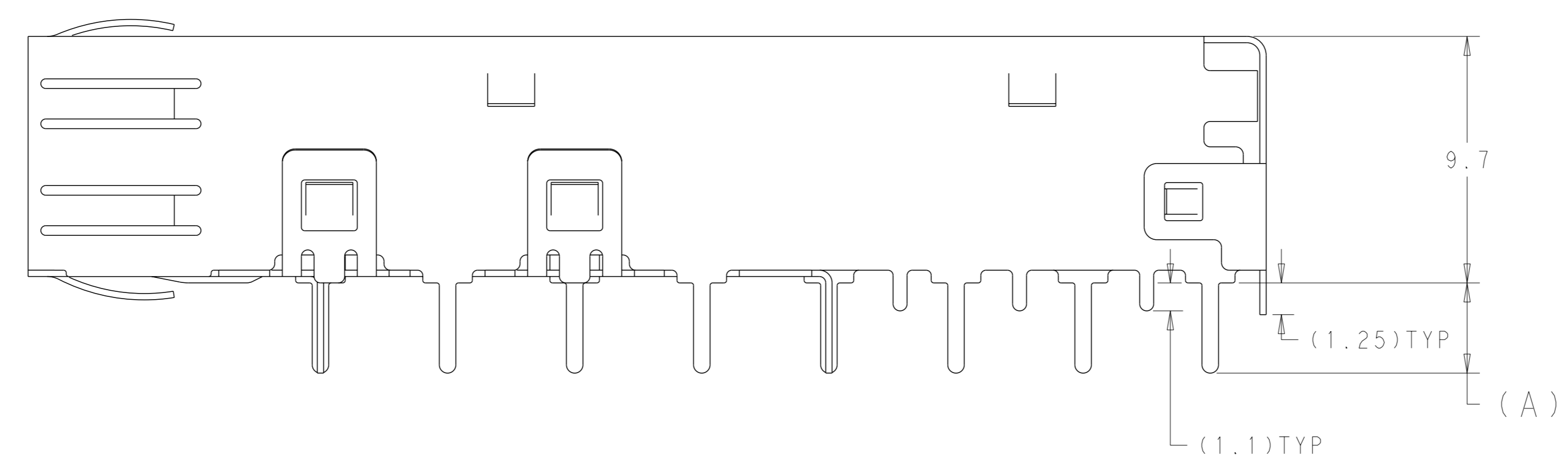
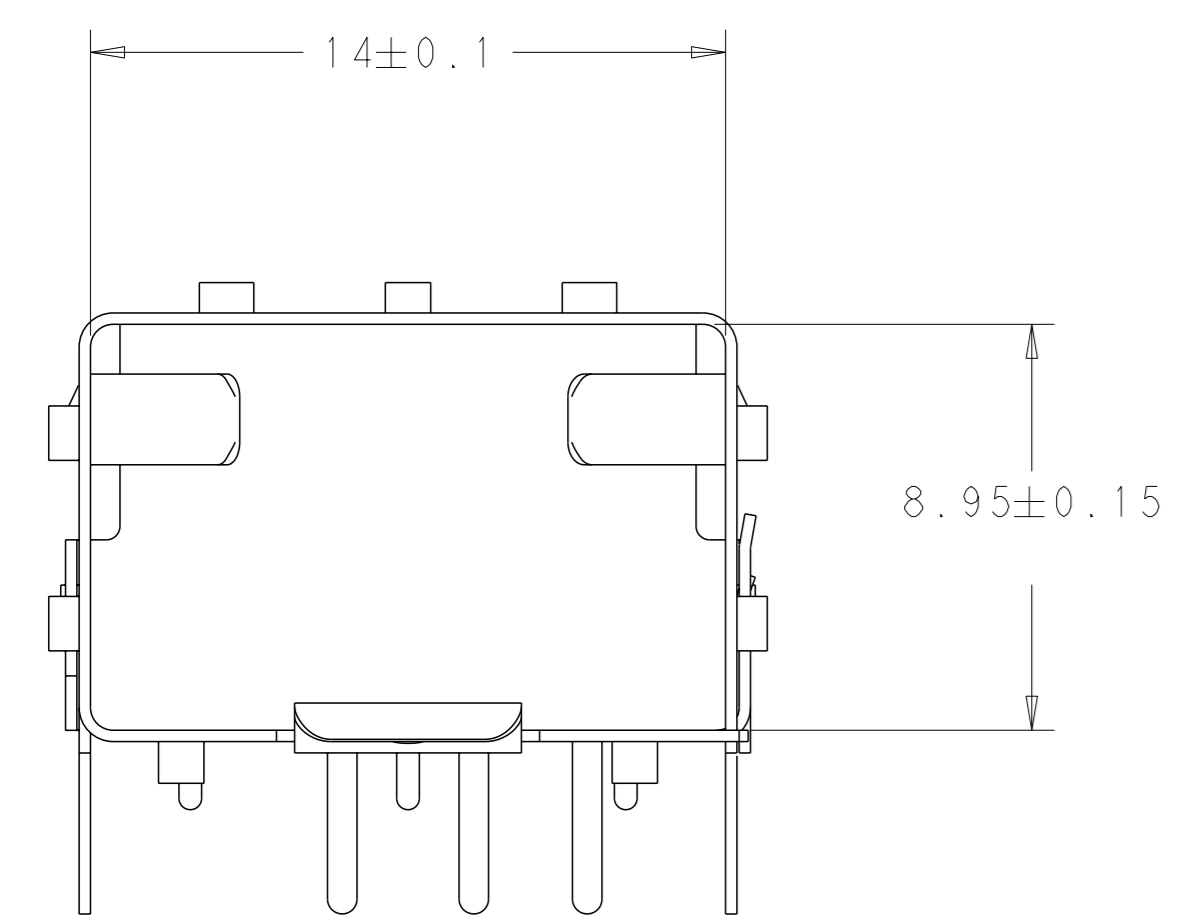

2227303-9  
 SCALE 3:1

WITHOUT EMI SPRING	REEL	1.80	3-2227303-2
WITH HEATSINK OPEN	△ REEL	1.25	2-2227303-4
WITH HEATSINK OPEN	△ REEL	1.25	2-2227303-2
WITHOUT EMI SPRING	△ TRAY	3.55	1-2227303-1
WITHOUT LOCATION PIN	△ TRAY	3.55	2227303-9
ALL PINS 3.55 LENGTH	△ TRAY	3.55	2227303-7
STANDARD TYPE WITH AIR VENTS, EMI SPRING, LOCATION PIN	REEL	1.25	1-2227303-3
	△ REEL	1.80	1-2227303-2
	TRAY	1.80	2227303-3
	REEL	1.80	2227303-2
	TRAY	3.55	2227303-1
DESCRIPTION	PACKAGING	A	PART NUMBER

THIS DRAWING IS A CONTROLLED DOCUMENT. DIMENSIONING AND TOLERANCING PER ASME Y14.5M-2009.		OWN: C. VALENTINE 19OCT2012	CHK: M. SCHMITT 19OCT2012	APVD: M. SCHMITT 19OCT2012	NAME: SFP, 1X1 SINGLE PIECE CAGE, SOLDER PIN
DIMENSIONS:	TOLERANCES UNLESS OTHERWISE SPECIFIED:	PRODUCT SPEC: 108-1950			SIZE: CAGE CODE DRAWING NO: A100779C=2227303
mm	0 PLC ±0.1 1 PLC ±0.1 2 PLC ±0.1 3 PLC ±0.1 4 PLC ±0.1 ANGLES ±°	APPLICATION SPEC: 114-13120			RESTRICTED TO: -
MATERIAL:	FINISH:	WEIGHT:	SCALE: 6:1	SHEET 1 OF 3	REV: C3
Customer Drawing		Customer Drawing			

LOC	DIST	REVISIONS			
GP	00	REV	DATE	OWN	APVD
		1			
		2			
		3			
		4			
		5			
		6			
		7			
		8			
		9			
		10			

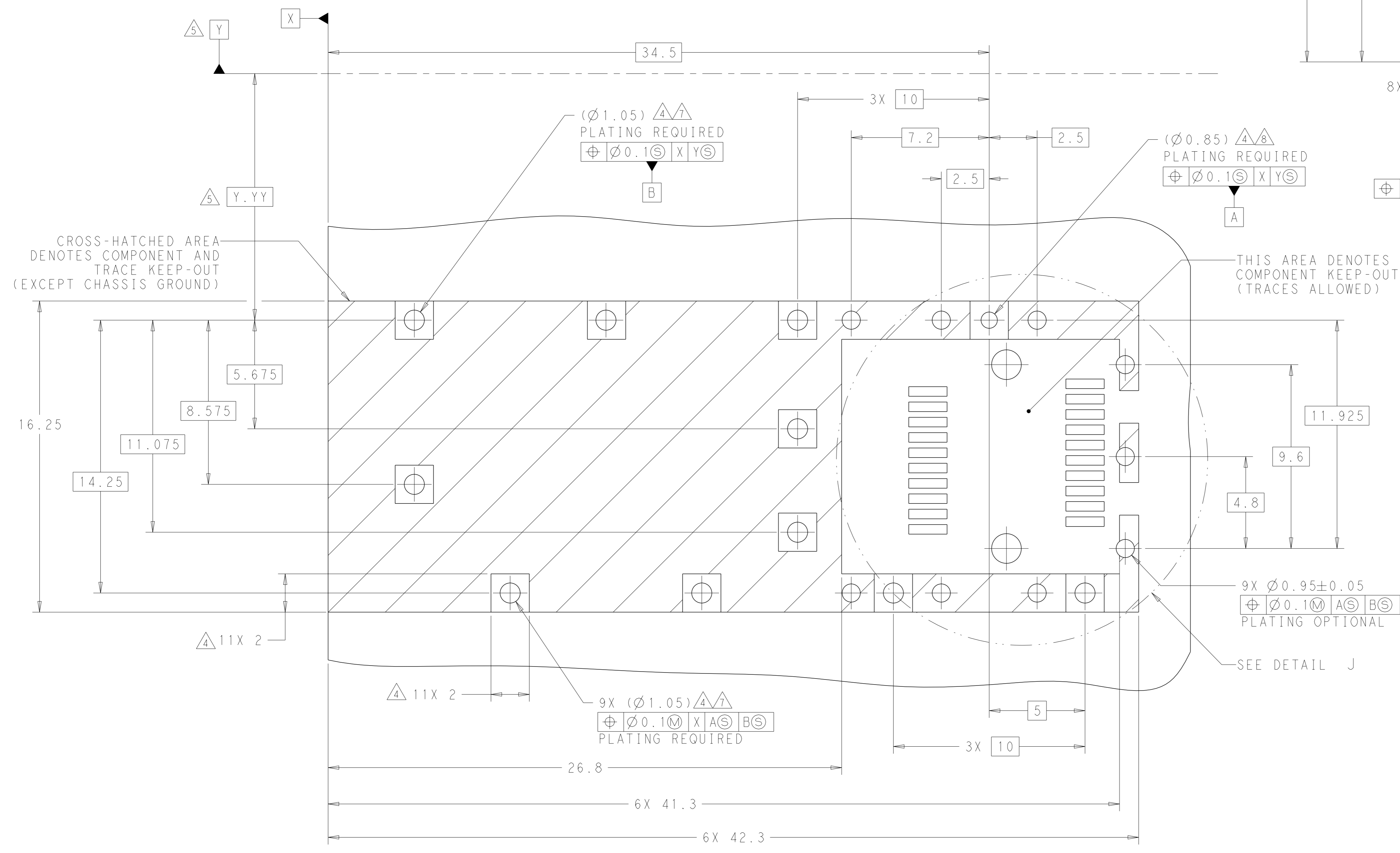
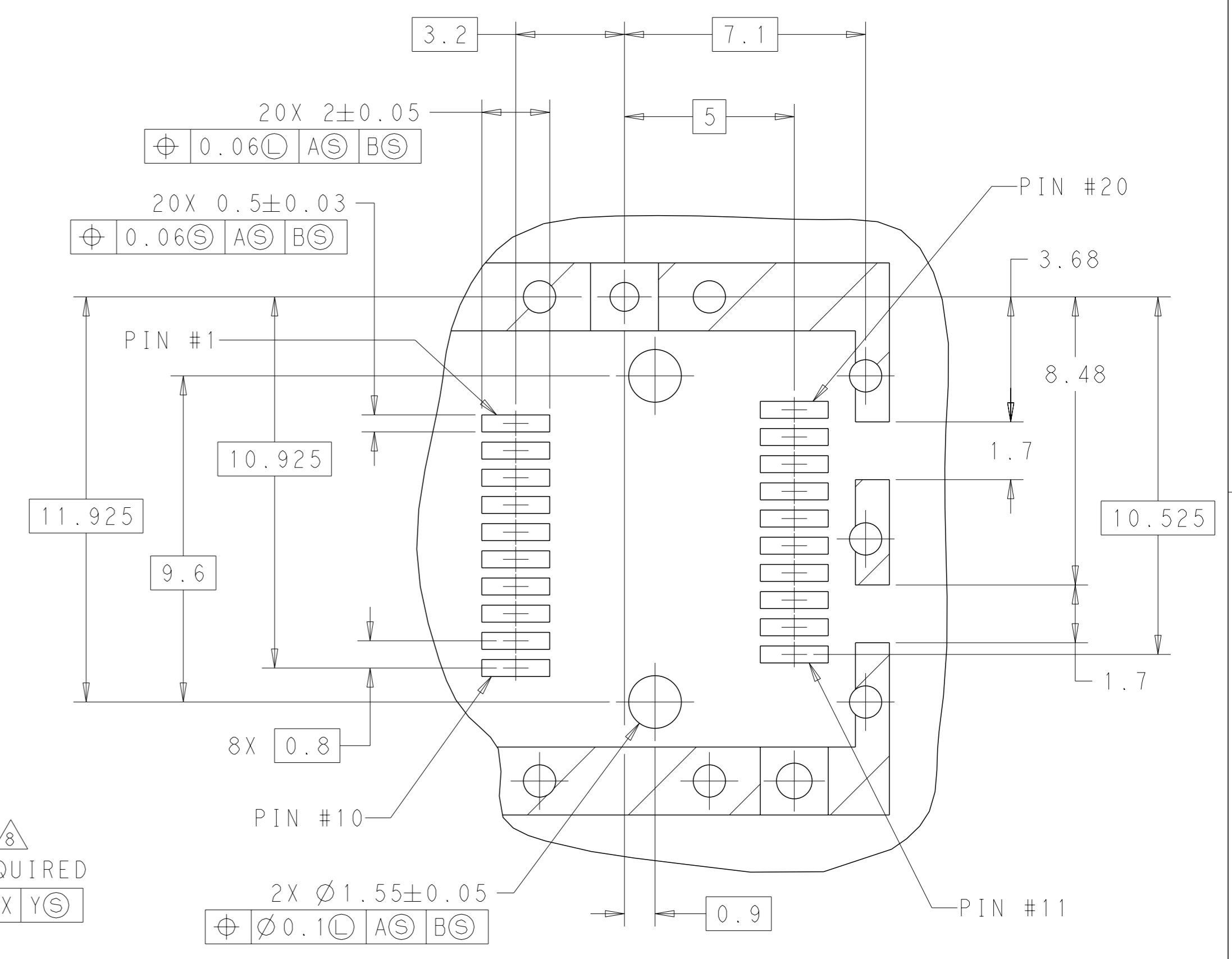
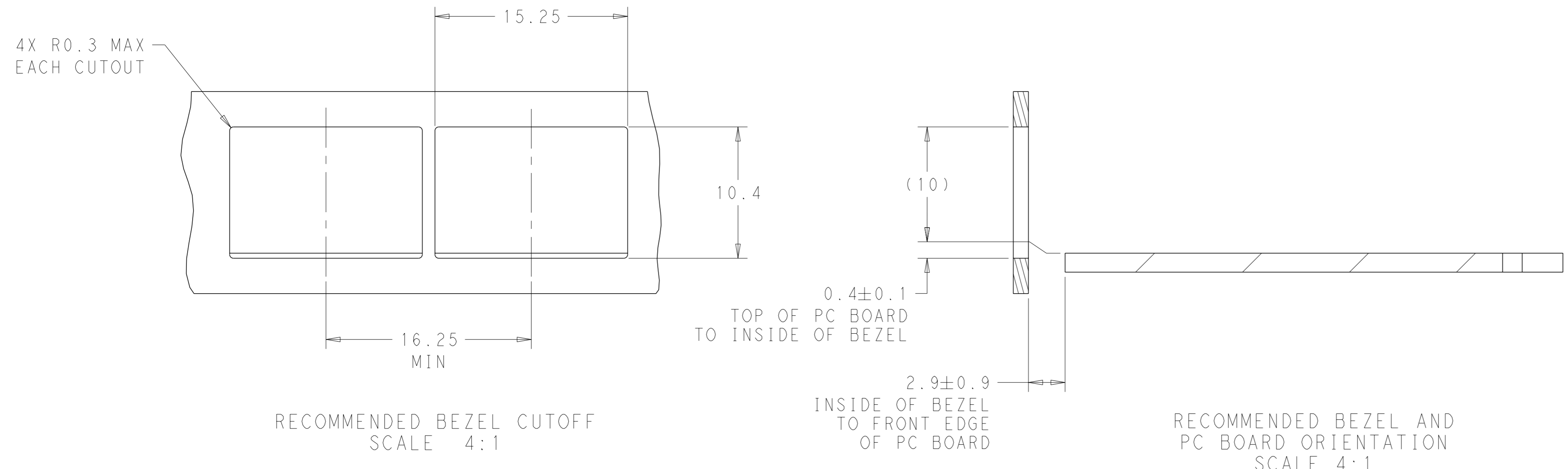

RECOMMENDED PCB LAYOUT SCALE 8:1

THIS DRAWING IS A CONTROLLED DOCUMENT. DIMENSIONING AND TOLERANCING PER ASME Y14.5M-2009.		OWN: C. VALENTINE 19OCT2012	TE Connectivity
DIMENSIONS: mm		CHK: M. SCHMITT 19OCT2012	
TOLERANCES UNLESS OTHERWISE SPECIFIED:		APVD: M. SCHMITT 19OCT2012	NAME: SFP, 1X1 SINGLE PIECE CAGE, SOLDER PIN
0 PLC	±0.1	PRODUCT SPEC	108-1950
1 PLC	±0.1	APPLICATION SPEC	114-13120
2 PLC	±0.1	SIZE	CAGE CODE DRAWING NO
3 PLC	±0.1	RESTRICTED TO	A100779C=2227303
4 PLC	±0.1	SCALE	6:1
ANGLES	±°	SHEET	2 OF 3
MATERIAL		REV	C3
FINISH		Customer Drawing	

LOC	DIST	REVISIONS			
P	LYR	DESCRIPTION	DATE	OWN	APVD
GP	00	SEE SHEET 1	-	-	-

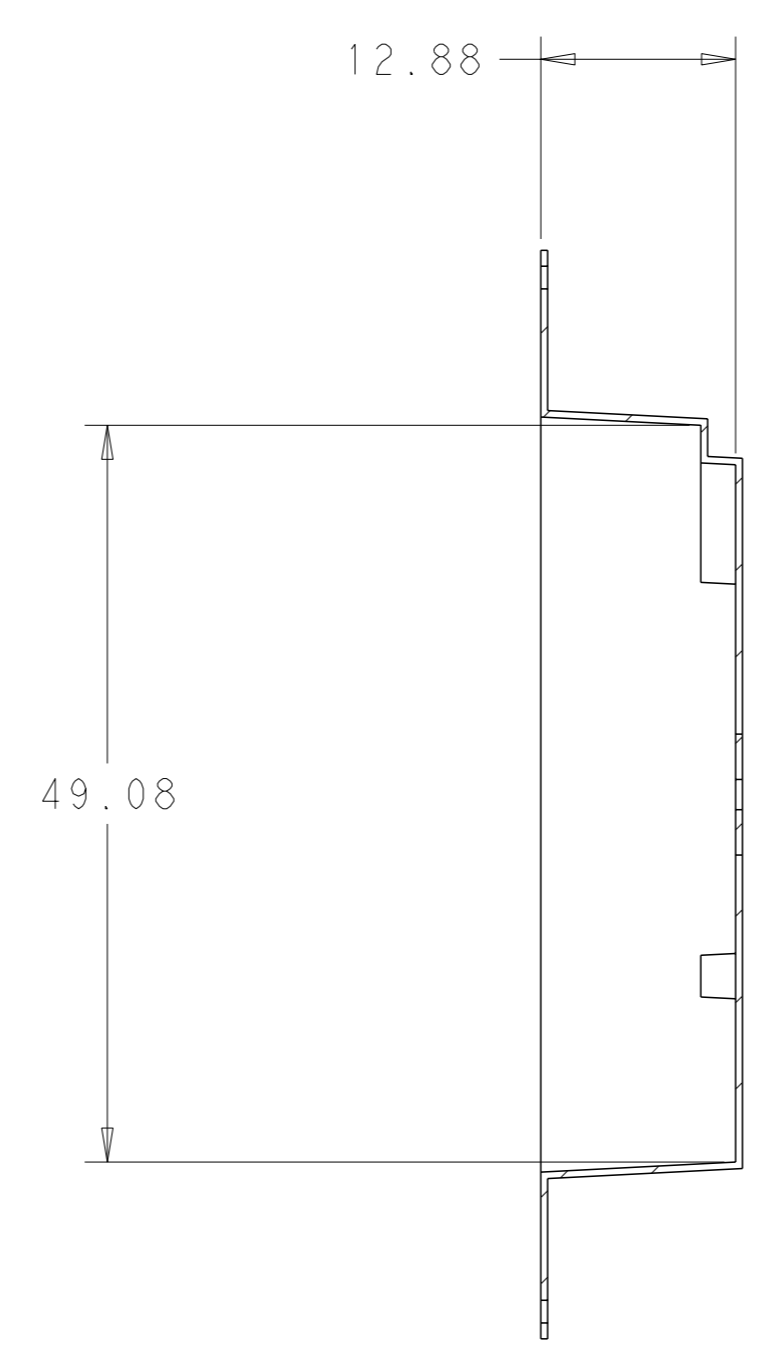
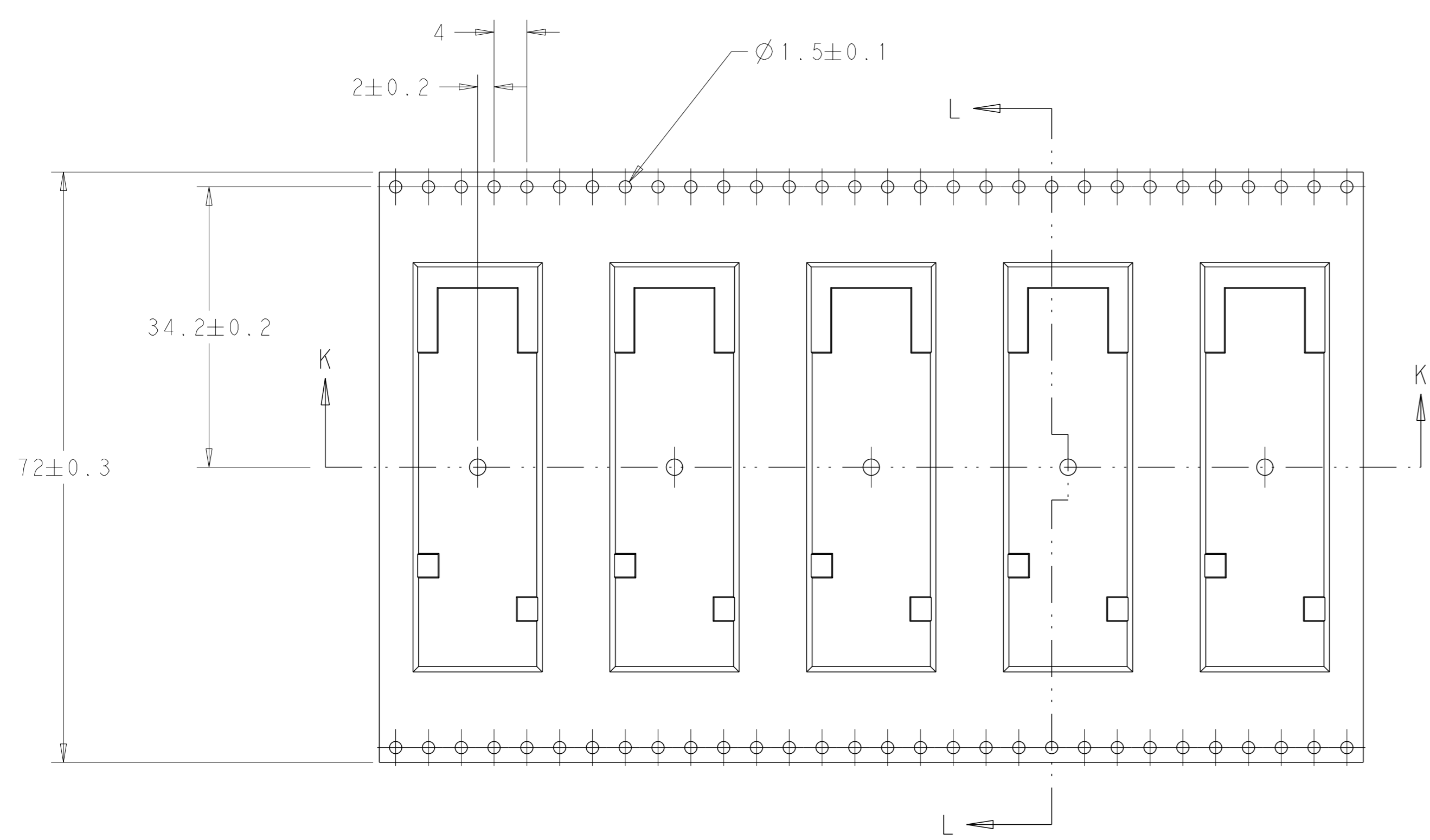

SECTION L-L

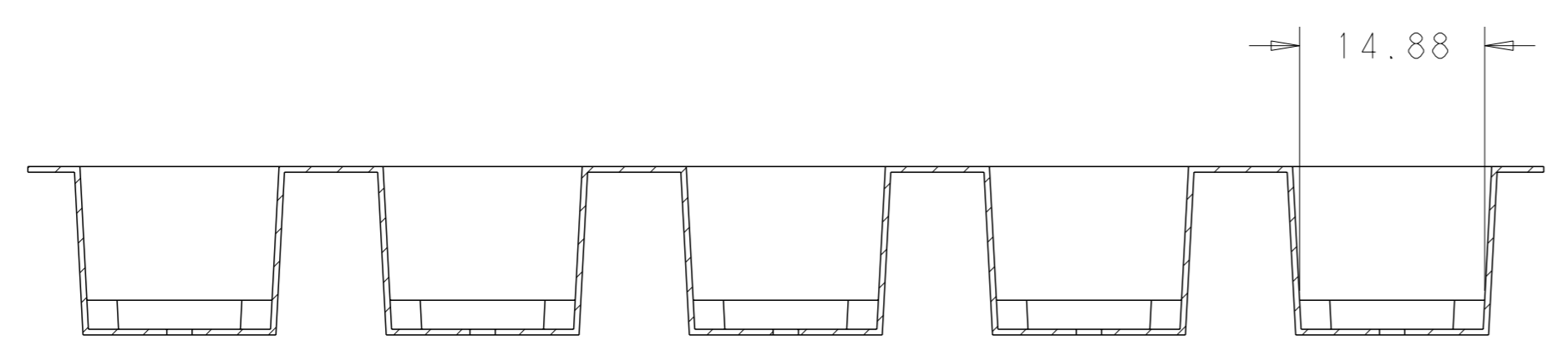

SECTION K-K  
SCALE 2:1

2227303-2 / 1-222303-2 REEL PACKAGING

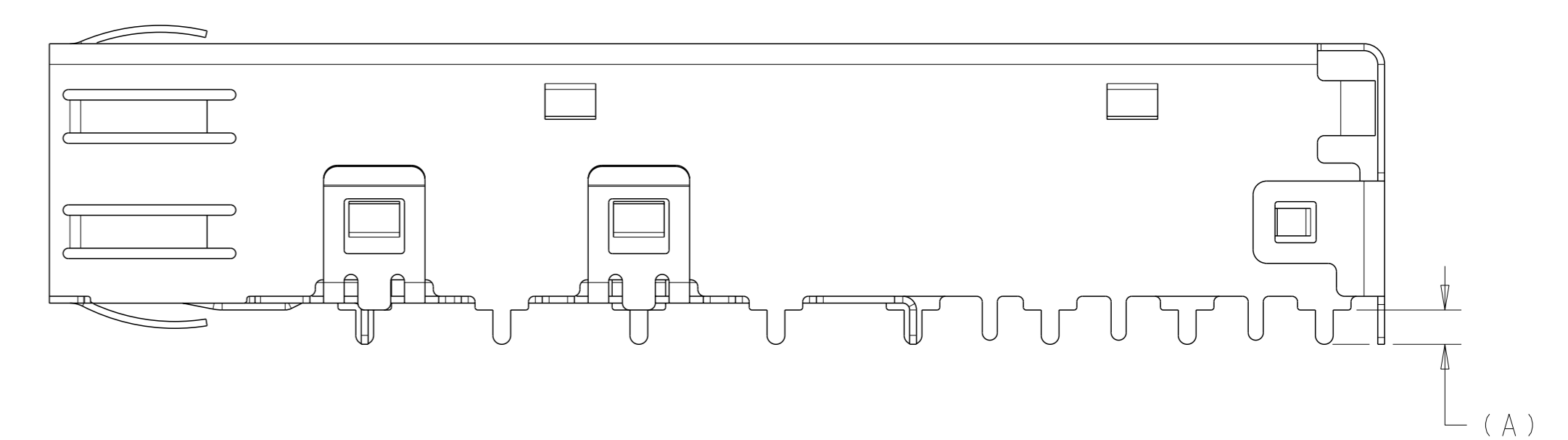
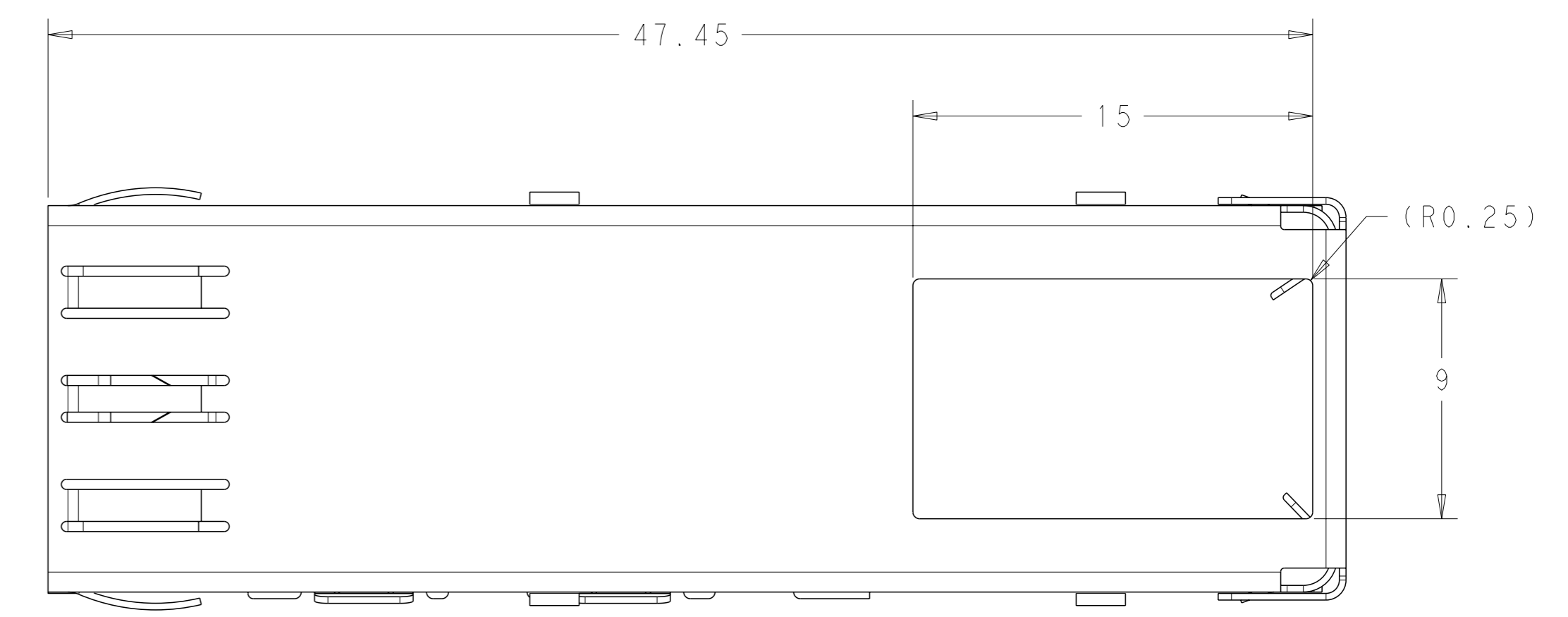

2-2227303-2 AS SHOWN  
UNMARKED DIMENSIONS SAME AS 2227303-1  
SCALE 5:1

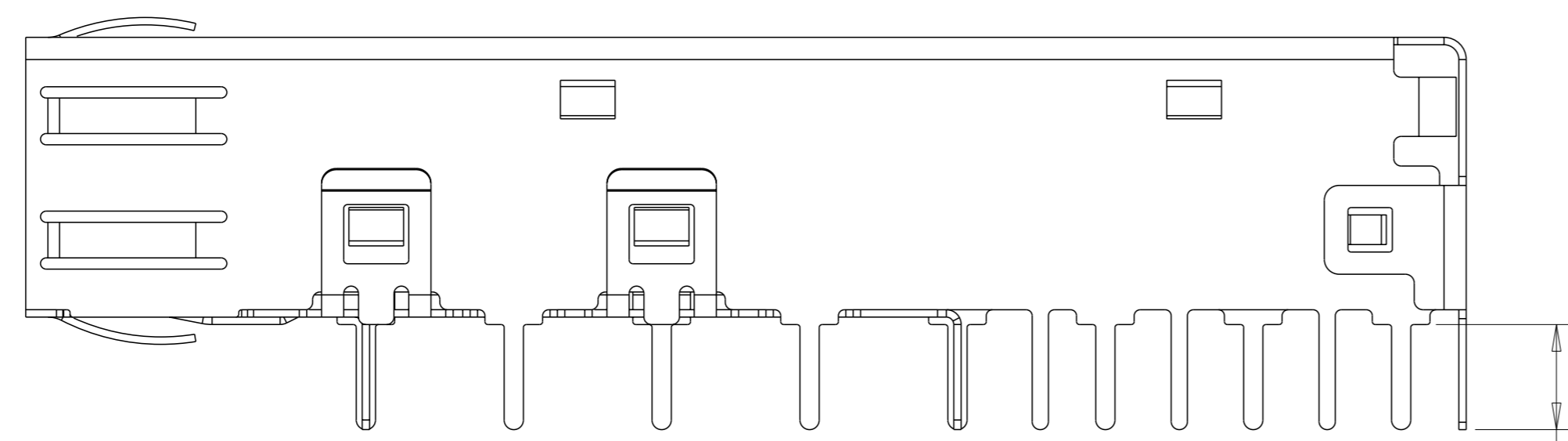
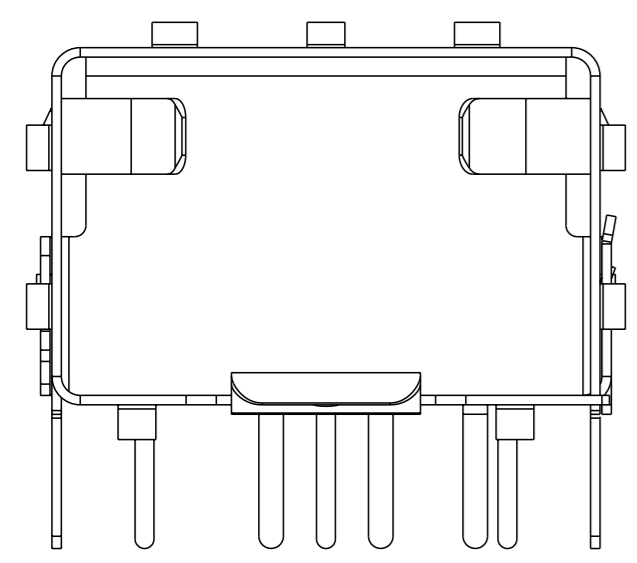

(A)  
APPLIED ALL PINS

2227303-7  
UNMARKED DIMENSIONS SAME AS 2227303-1  
SCALE 5:1

THIS DRAWING IS A CONTROLLED DOCUMENT. DIMENSIONING AND TOLERANCING PER ASME Y14.5M-2009		OWN: C. VALENTINE 19OCT2012	TE Connectivity
DIMENSIONS: mm		CHK: M. SCHMITT 19OCT2012	
TOLERANCES UNLESS OTHERWISE SPECIFIED:		APVD: M. SCHMITT 19OCT2012	NAME: SFP, 1X1 SINGLE PIECE CAGE, SOLDER PIN
0 PLC ±0.1	1 PLC ±0.1	PRODUCT SPEC	SIZE: 108-1950
2 PLC ±0.1	3 PLC ±0.1	APPLICATION SPEC	RESTRICTED TO
4 PLC ±	ANGLES ±	114-13120	SCALE: 6:1
MATERIAL:	FINISH:	WEIGHT:	SHEET 3 OF 3
Customer Drawing		A100779C=2227303	REV: C3

单击下面可查看定价，库存，交付和生命周期等信息

[>>TE Connectivity\(泰科\)](#)