

✓RoHS

## MS4425

### SPECIFICATIONS

- ◆ **PC Board Mountable Pressure Sensor**
- ◆ **0-100 mV Output**
- ◆ **Voltage Excitation**
- ◆ **Differential, Gage, and Absolute**
- ◆ **Temperature Compensated**

The MS4425 is a temperature compensated, piezoresistive silicon pressure sensor packaged in a dual-in-line configuration and intended for cost sensitive applications where excellent performance and long-term stability are required.

Integral temperature compensation is provided over a range of 0-50°C using laser-trimmed resistors. The pressure sensor is available in absolute, gage or differential pressure ranges from 0-1 to 0-300 psi. The pressure ports are 1/8" barbed ports which mate with 3/32" ID tubing. These tubes are parallel to the printed circuit board to allow other boards to be located above the sensor. For a vertical mounted tube in gage or absolute pressure, refer to the MS4426.

## FEATURES

- Dual-in-Line Package
- 0°C to 50°C Compensated Temperature Range
- ±0.15% Pressure Non Linearity
- Solid State Reliability

## APPLICATIONS

- Medical Instruments
- Altitude and Airspeed Measurements
- Process Control
- Factory Automation
- Leak Detection

## STANDARD RANGES

Range	psid	psig	psia
0 to 1	+	+	
0 to 5	+	+	
0 to 15	+	+	+
0 to 30	+	+	+
0 to 50	+	+	+
0 to 100	+	+	+
0 to 150	+	+	+
0 to 300	+	+	+

## PERFORMANCE SPECIFICATIONS

Supply Voltage: 12V

Ambient Temperature: 25°C (unless otherwise specified)

Pressure applied to Port 2

PARAMETERS	MIN	TYP	MAX	UNITS	NOTES
Span (0-1 psi)	17.6	18	18.4	mV	1
Span (0-5 psi)	58	60	62	mV	1
Span (0-15 to 0-50 psi)	88	90	92	mV	1
Span (0-100 & 0-300 psi)	98	100	102	mV	1
Span (0-150 psi)	148	150	152	mV	1
Zero Pressure Output	-1	±0.2	1	mV	1
Pressure Non Linearity (Gage & Absolute)	-0.15		0.15	% Span	2
Pressure Non Linearity (Differential)	-0.25		0.25	% Span	2
Pressure Hysteresis	-0.20	±0.05	0.20	% Span	
Input Resistance	5	15	25	KΩ	
Output Resistance	3500	5000	6500	Ω	
Temperature Error – Span	-1	0.3	1	% Span	3
Temperature Error – Zero	-0.75	±0.2	0.75	mV	3
Supply Voltage		12	20	V	
Long Term Stability (Offset & Span)		±0.1		mV	4
Pressure Overload (Differential)			3X	Rated	5
Common Mode Pressure			400	psi	
Compensated Temperature	0		50	°C	
Operating Temperature	-25		85	°C	
Storage Temperature	-40		125	°C	
Humidity	0		85	% RH	
Weight			3	grams	
Solder Temperature	260°C Max 5 Sec.				6
Media	Non-Corrosive Dry Gases Compatible with Silicon, Pyrex, RTV, Ceramic & Gold				

## Notes

1. Ratiometric to supply voltage.
2. Best fit straight line. Non linearity for 5 psi Differential devices is 0.75%.
3. Maximum temperature error between 0°C and 50°C with respect to 25°C. For errors beyond the compensated temperature, see Temperature Error Multiplier Chart below.
4. Long term stability over a one year period with constant voltage and temperature.
5. 3X or 400 psi max, whichever is less.
6. For more details refer to 4425/4426 Mounting Application Note.

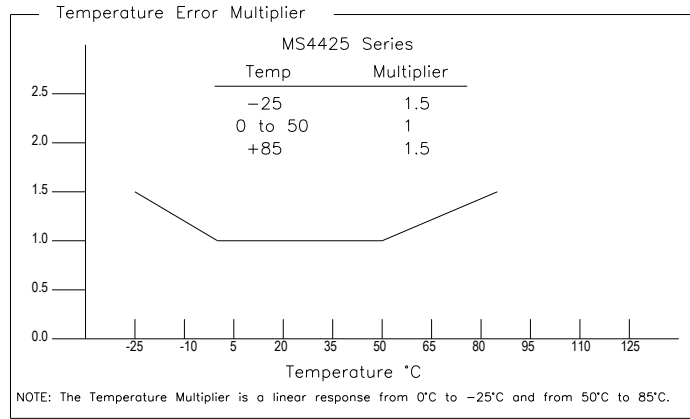

DIMENSION

DIMENSIONS ARE IN INCHES [mm]

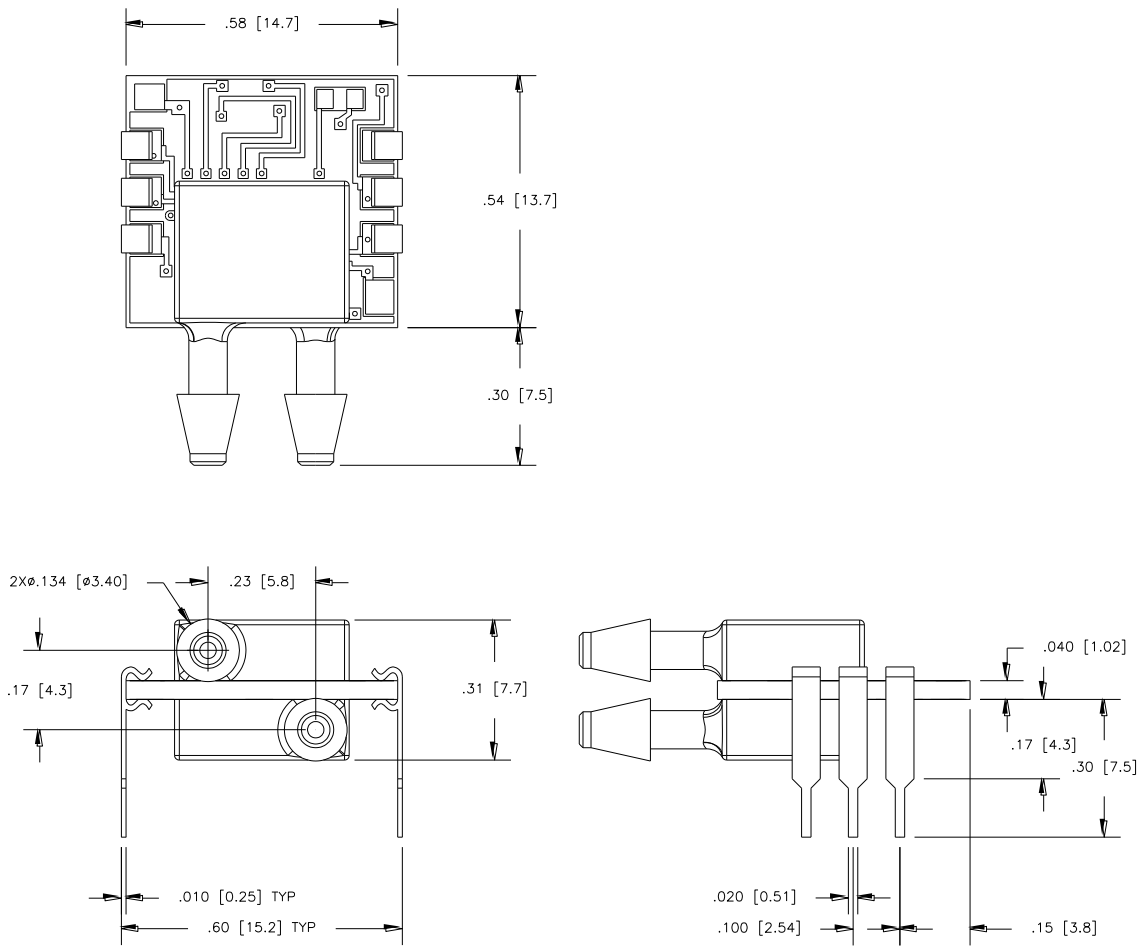

MS4425-xxxDy

DIMENSIONS ARE IN INCHES [mm]

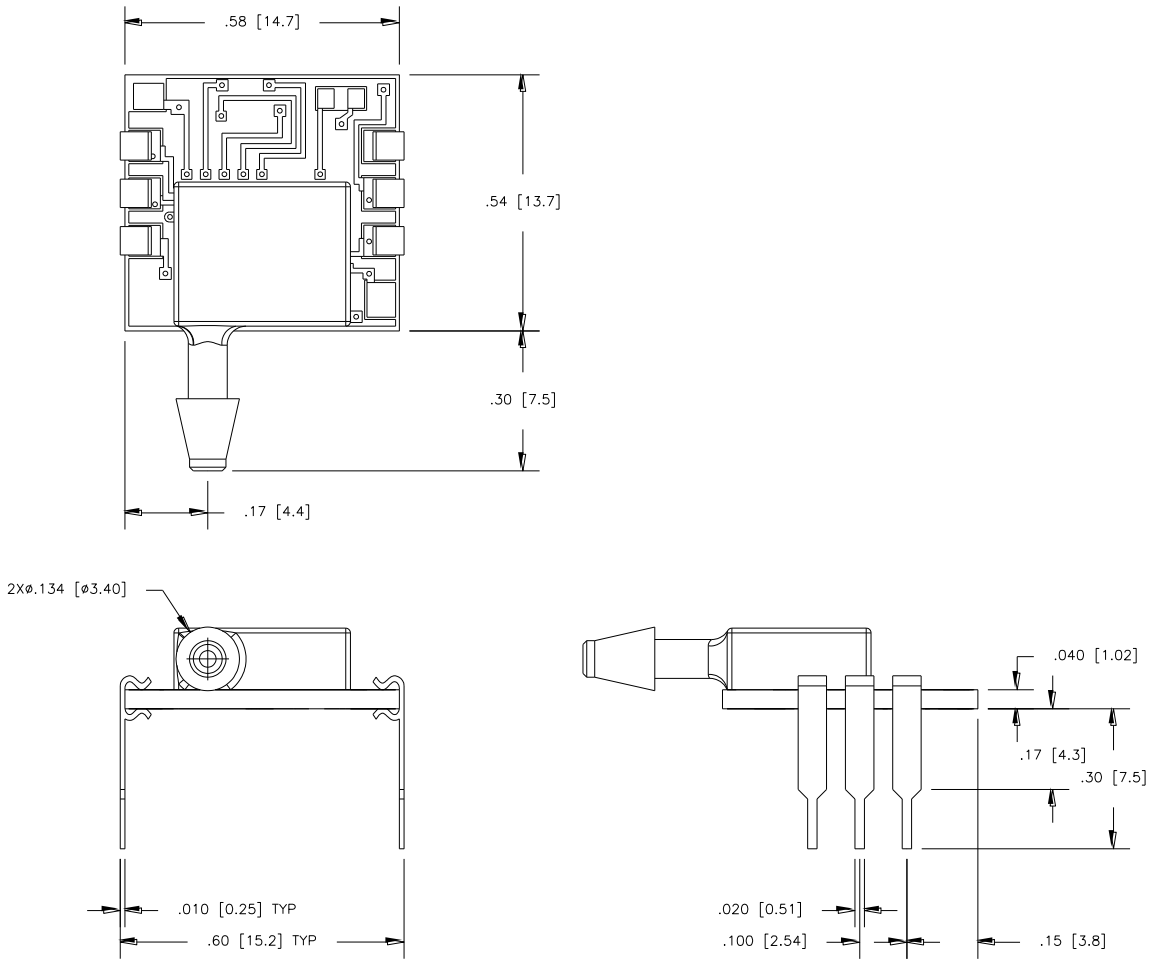

MS4425-xxxA/Gy

CONNECTIONS

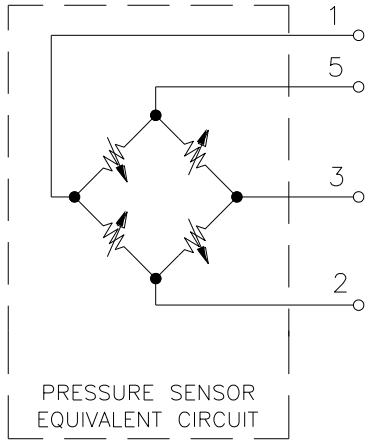

MS4425-XXXD

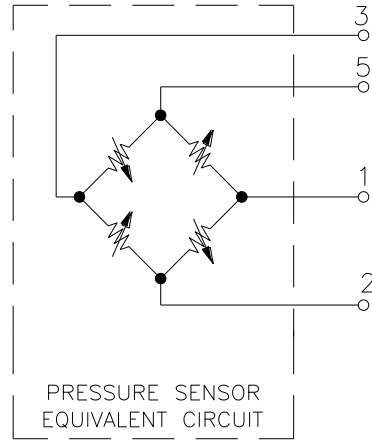

MS4425-XXXA/G

PACKAGE STYLE, PINOUT, AND PORT DESIGNATION

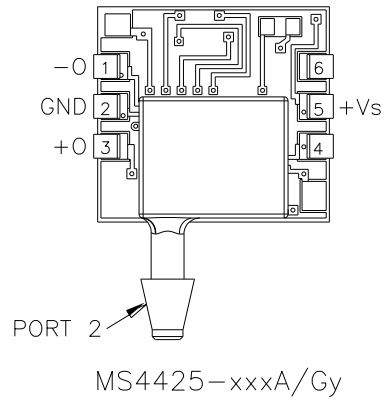
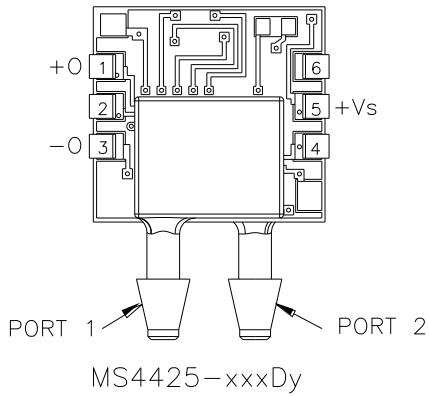

ORDERING INFORMATION

4425 - 005 D F

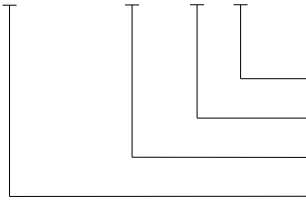

Coating (F - Gel Fill, Blank = No Coating)  
Type (D = Differential, A = Absolute, G = Gage)  
Pressure Range  
Model

**NORTH AMERICA**

Measurement Specialties, Inc.,  
a TE Connectivity company  
Tel: 800-522-6752  
Email: [customercare.frmt@te.com](mailto:customercare.frmt@te.com)

**EUROPE**

Measurement Specialties (Europe), Ltd.,  
a TE Connectivity Company  
Tel: 800-440-5100  
Email: [customercare.bevx@te.com](mailto:customercare.bevx@te.com)

**ASIA**

Measurement Specialties (China) Ltd.,  
a TE Connectivity company  
Tel: 0400-820-6015  
Email: [customercare.shzn@te.com](mailto:customercare.shzn@te.com)

**TE.com/sensorsolutions**

Measurement Specialties, Inc., a TE Connectivity company.

Measurement Specialties, TE Connectivity, TE Connectivity (logo) and EVERY CONNECTION COUNTS are trademarks. All other logos, products and/or company names referred to herein might be trademarks of their respective owners.

The information given herein, including drawings, illustrations and schematics which are intended for illustration purposes only, is believed to be reliable. However, TE Connectivity makes no warranties as to its accuracy or completeness and disclaims any liability in connection with its use. TE Connectivity's obligations shall only be as set forth in TE Connectivity's Standard Terms and Conditions of Sale for this product and in no case will TE Connectivity be liable for any incidental, indirect or consequential damages arising out of the sale, resale, use or misuse of the product. Users of TE Connectivity products should make their own evaluation to determine the suitability of each such product for the specific application.

© 2015 TE Connectivity Ltd. family of companies All Rights Reserved.

单击下面可查看定价，库存，交付和生命周期等信息

[>>TE Connectivity\(泰科\)](#)