

THIS DRAWING IS UNPUBLISHED. RELEASED FOR PUBLICATION
 © COPYRIGHT - TE Connectivity Ltd. ALL RIGHTS RESERVED.

REVISIONS					
P	LTR	DESCRIPTION	DATE	DWN	APVD
	F4	REV PER ECR 09-022345	12OCT09	JR	TM
	F5	REVISED PER ECO-17-008114	28MAY2018	RS	DR
	G	REVISED PER ECO-19-002444	18FEB2019	RS	DR

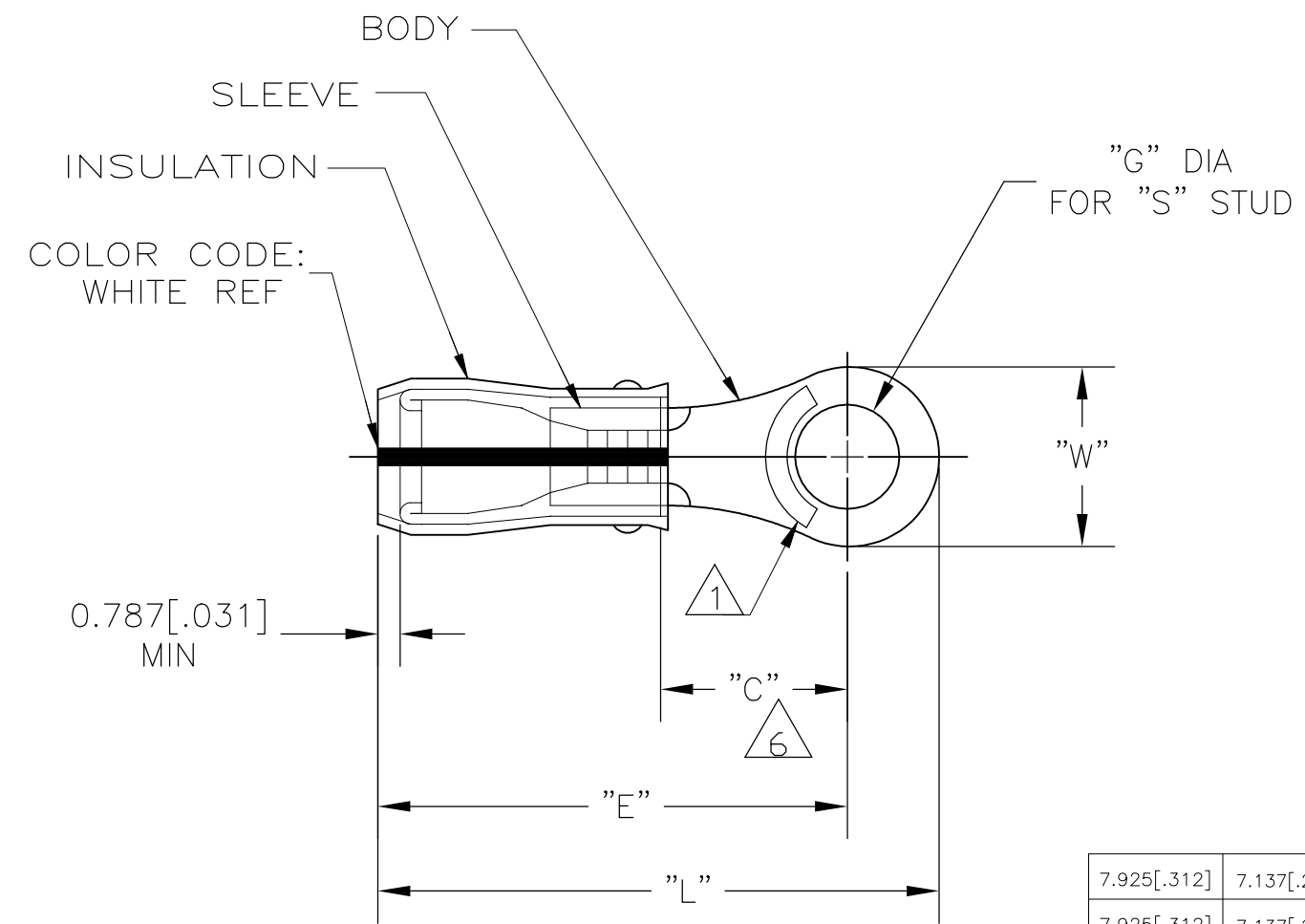

- 1 STAMP AMP 24-20* APPROX AS SHOWN
- 2 WIRE INSULATION DIA: 1.016-2.540 [.040-.100]
- 3 BODY MATERIAL THK: 0.584±0.051 [.023±.002]
- 4 BODY & SLEEVE: TIN-LEAD (93-7) PLATE PER ASTM B545, (3% MIN LEAD CONTENT)
- 5 BODY & SLEEVE- CU PER ASTM B152 INSULATION - PVF2, COLOR - NATURAL
- 6 APPLIES FROM EDGE OF METAL WIRE BARREL TO CENTER OF STUD HOLE.
- 7 OBSOLETE - NO REPLACEMENT

7.925[.312]	7.137[.281] MIN	16.815[.662] MAX	5.004±0.076[.197±.003]	#10	20.980[.826] MAX	2500	TAPE & REEL	53809-8	7
7.925[.312]	7.137[.281] MIN	16.815[.662] MAX	4.343±0.076[.171±.003]	#8	20.980[.826] MAX	2500	TAPE & REEL	53809-7	7
7.925[.312]	7.137[.281] MIN	16.815[.662] MAX	5.004±0.076[.197±.003]	#10	20.980[.826] MAX	1000	LOOSE PIECE	53809-6	7
7.925[.312]	7.137[.281] MIN	16.815[.662] MAX	4.343±0.076[.171±.003]	#8	20.980[.826] MAX	1000	LOOSE PIECE	53809-5	7
7.137[.281]	6.350[.250] MIN	16.027[.631] MAX	3.683±0.076[.145±.003]	#6	19.787[.779] MAX	2500	TAPE & REEL	53809-4	7
7.137[.281]	6.350[.250] MIN	16.027[.631] MAX	3.023±0.076[.119±.003]	#4	19.787[.779] MAX	2500	TAPE & REEL	53809-3	7
7.137[.281]	6.350[.250] MIN	16.027[.631] MAX	3.683±0.076[.145±.003]	M3.5[#6]	19.787[.779] MAX	1000	LOOSE PIECE	53809-2	7
7.137[.281]	6.350[.250] MIN	16.027[.631] MAX	3.023±0.076[.119±.003]	#4	19.787[.779] MAX	1000	LOOSE PIECE	53809-1	7
"W"	"C"	"E"	"G" DIA	"S"	"L"	QTY	PACKAGE TYPE	PART NO	

CUSTOMER SERVICE SYSTEMS		MAX RECOMMENDED OPERATING TEMPERATURE: 150°C[302°F] MAX	THIS DRAWING IS A CONTROLLED DOCUMENT.		DWN JR RUTH 28JUL05								
FOR ADDITIONAL PRODUCT INFORMATION OR COPIES OF DRAWINGS AND TECHNICAL DOCUMENTS	PRODUCT INFORMATION CENTER 1-800-522-6752	VOLTAGE RATING: -	DIMENSIONS: mm [INCHES]	TOLERANCES UNLESS OTHERWISE SPECIFIED:	CHK T MICHIELUTTI 28JUL05					NAME TERMINAL, RING TONGUE, PVF2 , PIDG WIRE SIZE: 24-20 AWG			
FOR APPLICATION TOOLING INFORMATION	TOOLING ASSISTANCE CENTER 1-800-722-1111	CIRCULAR MIL AREA: 0.16-0.65mm² [320-1,290] STRANDED			APVD T MICHIELUTTI 28JUL05	RESTRICTED TO							
FOR ORDER ENTRY	1-800-526-5142	THIS DRAWING IS A CONTROLLED DOCUMENT FOR AMP INCORPORATED. IT IS SUBJECT TO CHANGE AND THE CONTROLLING ENGINEERING ORGANIZATION SHOULD BE CONTACTED FOR THE LATEST REVISION.	MATERIAL - 5	FINISH - 4	PRODUCT SPEC -	APPLICATION SPEC -	WEIGHT -	SIZE A3	CAGE CODE 00779	DRAWING NO C-53809	SCALE 4:1	SHEET 1 OF 1	REV G

单击下面可查看定价，库存，交付和生命周期等信息

[>>TE Connectivity\(泰科\)](#)