

THIS DRAWING IS UNPUBLISHED. RELEASED FOR PUBLICATION .19
 (C) COPYRIGHT 19 BY AMP INCORPORATED. ALL RIGHTS RESERVED.

LOC		DIST		REVISIONS			
P	LTR	DESCRIPTION	DATE	DWN	APVD		
GP	00	0	RELEASED PER NPR	13JUL01	JG	JK	

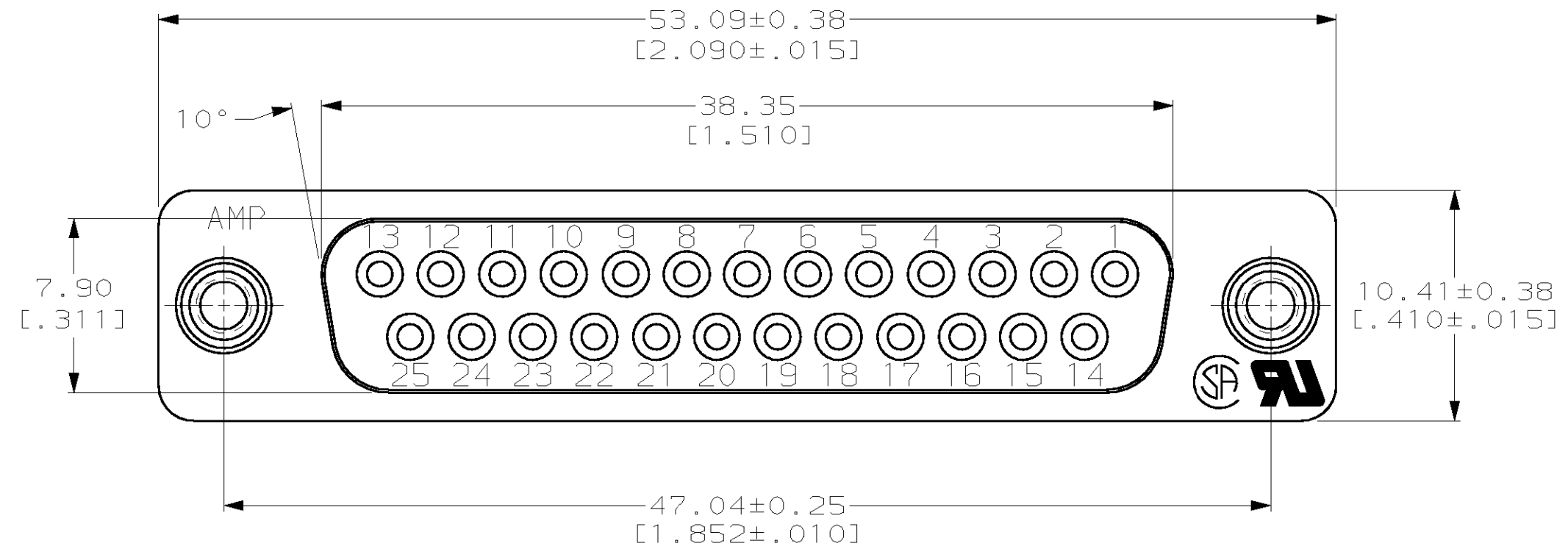

- 1 HOUSING: GLASS FILLED NYLON, UL 94V0 RATED, COLOR BLACK.
CONTACTS: PHOSPHOR BRONZE PER QQ-B-750.
SCREWLOCKS: BRASS QQ-B-626.
- 2 GOLD PLATING PER MIL-G-45204, TIN PLATING PER MIL-T-10727,
NICKEL PLATING PER QQ-N-290, COPPER PLATING PER MIL-C-14550.
- 3 CONTACTS: 0.00076[.00030] MIN GOLD FOR A LENGTH OF 2.54[.100]
MIN FROM MATING END, 0.00254[.00100] MIN TIN OR TIN-LEAD FOR
A LENGTH OF 3.18[.125] FROM SOLDER END, ALL OVER 0.00127
[.00050] NICKEL.
SCREWLOCKS: 0.00127[.00050] MIN NICKEL OVER COPPER FLASH.
- 4. ASSEMBLY IS COMPATIBLE WITH TYPICAL HIGH TEMPERATURE SOLDERING
APPLICATIONS TO A MAXIMUM OF 225°C FOR A MAXIMUM DURATION OF
90 SECONDS.

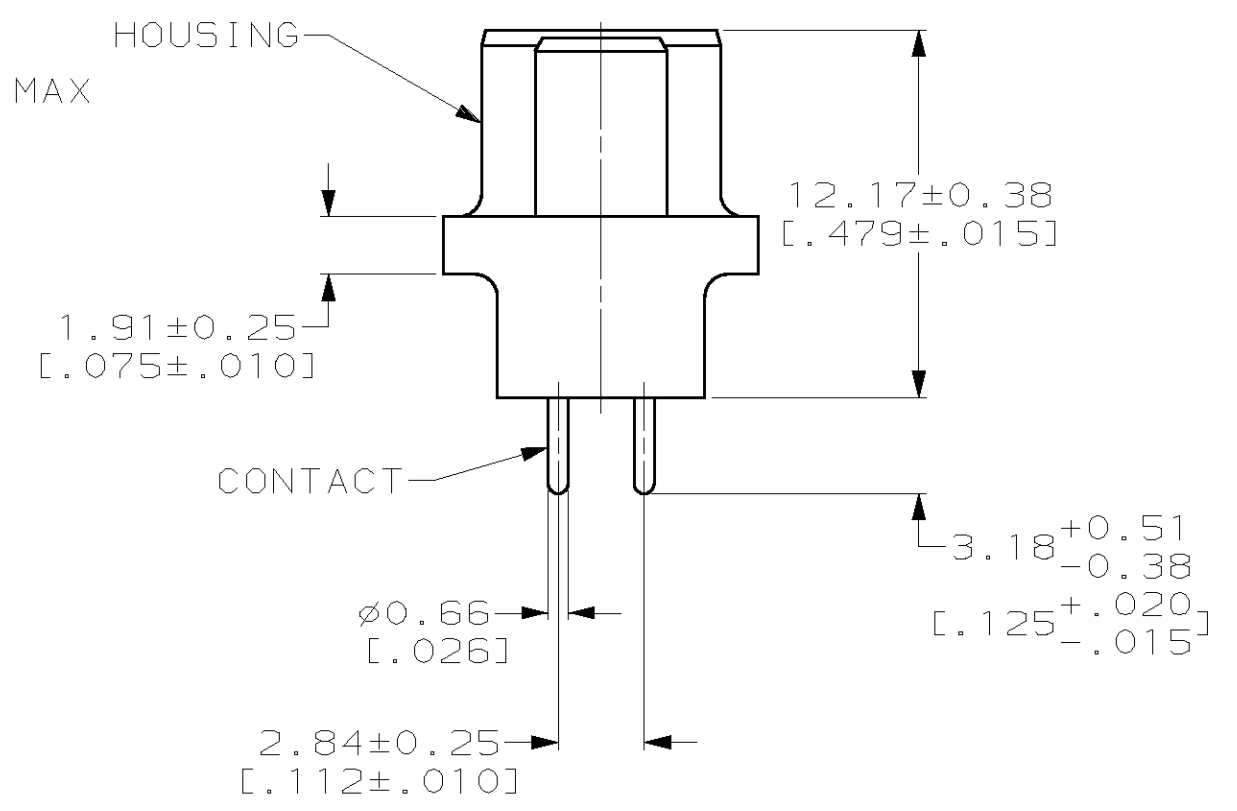
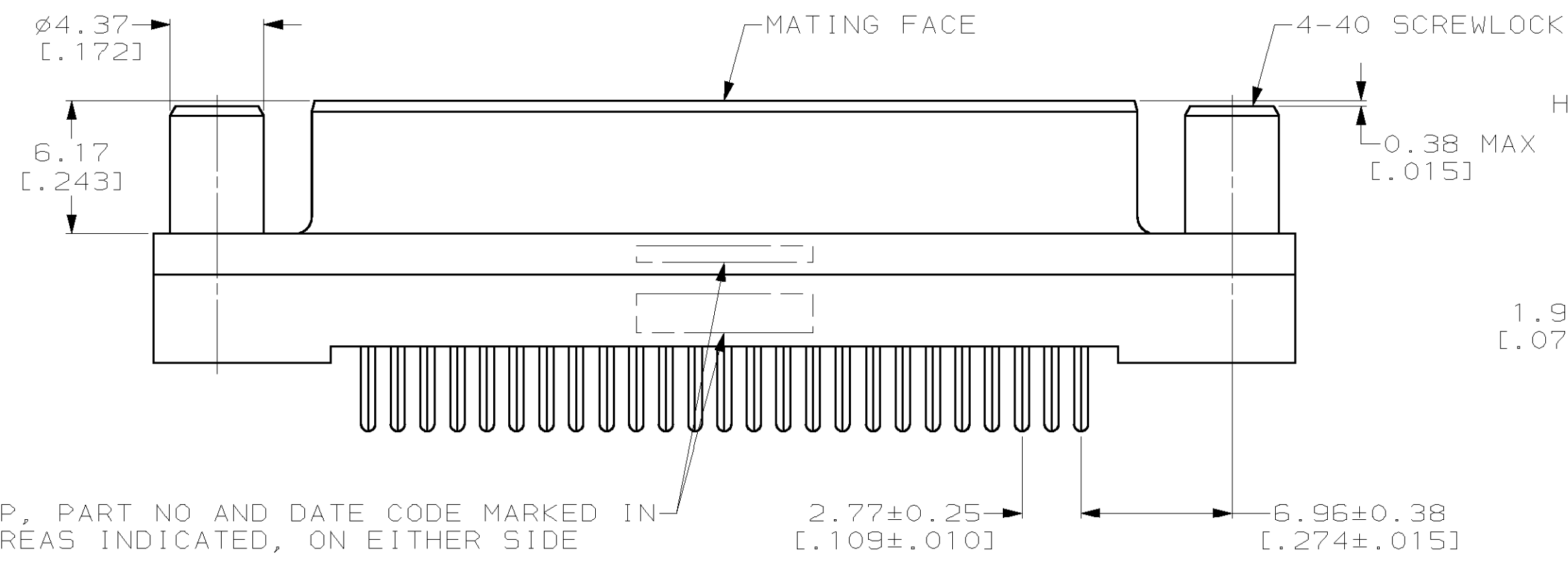

AMP, PART NO AND DATE CODE MARKED IN AREAS INDICATED, ON EITHER SIDE

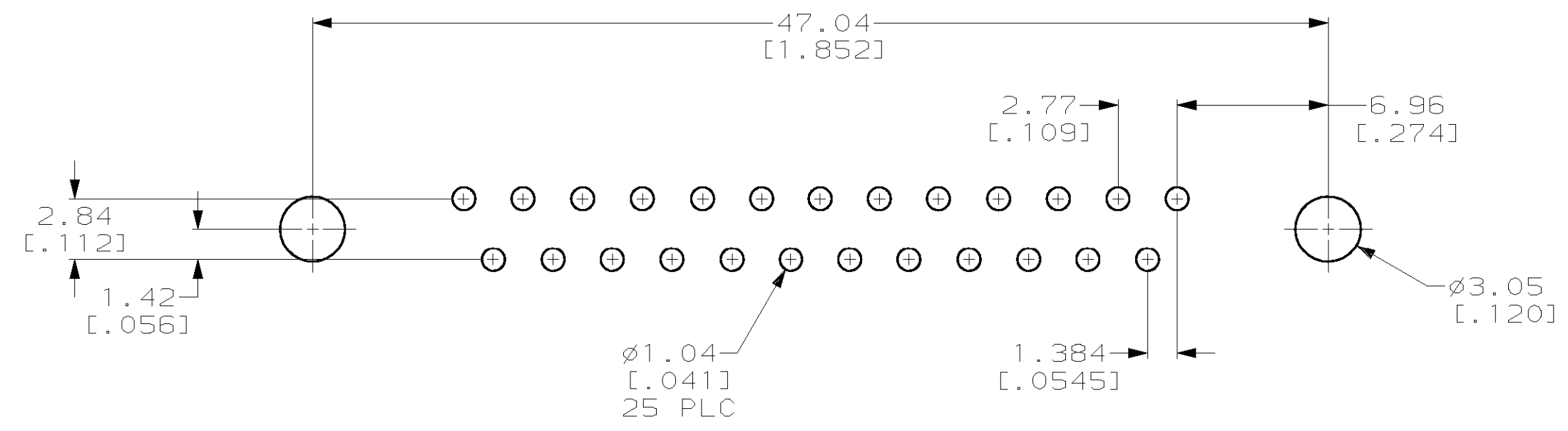

RECOMMENDED PC BOARD MOUNTING DIMENSIONS

COPYRIGHT 2001 TYCO ELECTRONICS CORP ALL RIGHT RESERVED

788833-1
PART NUMBER

THIS DRAWING IS A CONTROLLED DOCUMENT.		DWN J.GERACE 13JUL01	AMP Incorporated Harrisburg, PA 17105-3608
DIMENSIONS: mm (INCHES)		CHK J.KOPPENHEFFER 13JUL01	
TOLERANCES UNLESS OTHERWISE SPECIFIED:		APVD S.GOOD 13JUL01	
0 PLC ±- 1 PLC ±- 2 PLC ±0.13(.005) 3 PLC ±- 4 PLC ±- ANGLES ±2°		NAME RECEPTACLE ASSEMBLY, SIZE 3, 25 POS, VERTICAL, AMPLIMITE™ HD-20	
MATERIAL	FINISH	PRODUCT SPEC 108-40025	APPLICATION SPEC
		SIZE	CAGE CODE
		WEIGHT	DRAWING NO
		CUSTOMER DRAWING	RESTRICTED TO
		SCALE 4:1	SHEET 1 OF 1
			REV 0

788833

单击下面可查看定价，库存，交付和生命周期等信息

[>>TE Connectivity\(泰科\)](#)