

REVISIONS				
P.	LTN	DESCRIPTION	DATE	OWN APVD
B		REVISED PER ECO-18-008361	29MAY2018	CJV EDB
C		REVISED PER ECO-18-009057	12JUN2018	MS EB
D		REVISED PER ECO-18-013395	12SEP2018	CJV EDB
F		REVISED PER ECO-20-002354	05DEC2019	ES SH

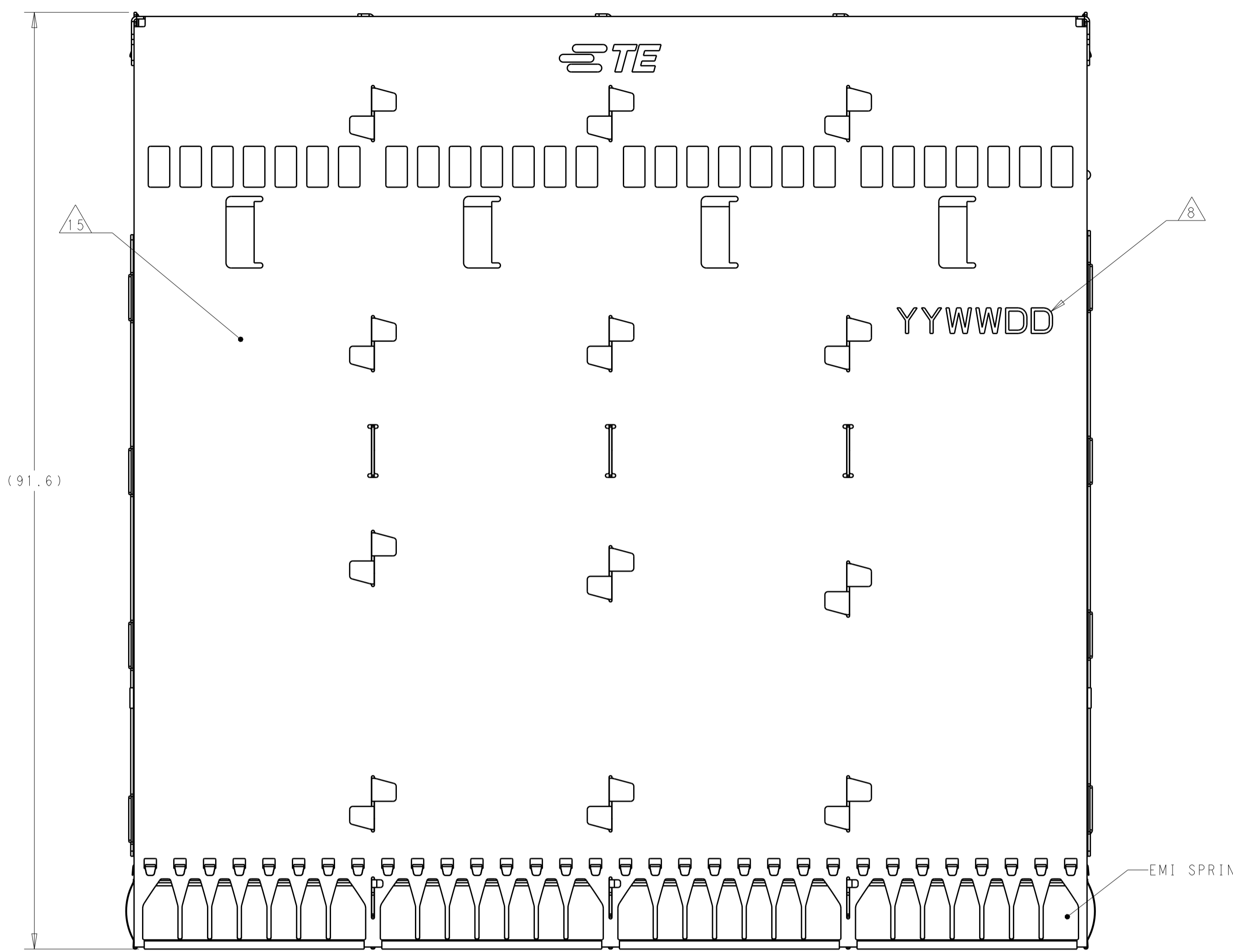

2315853-1 AS SHOWN

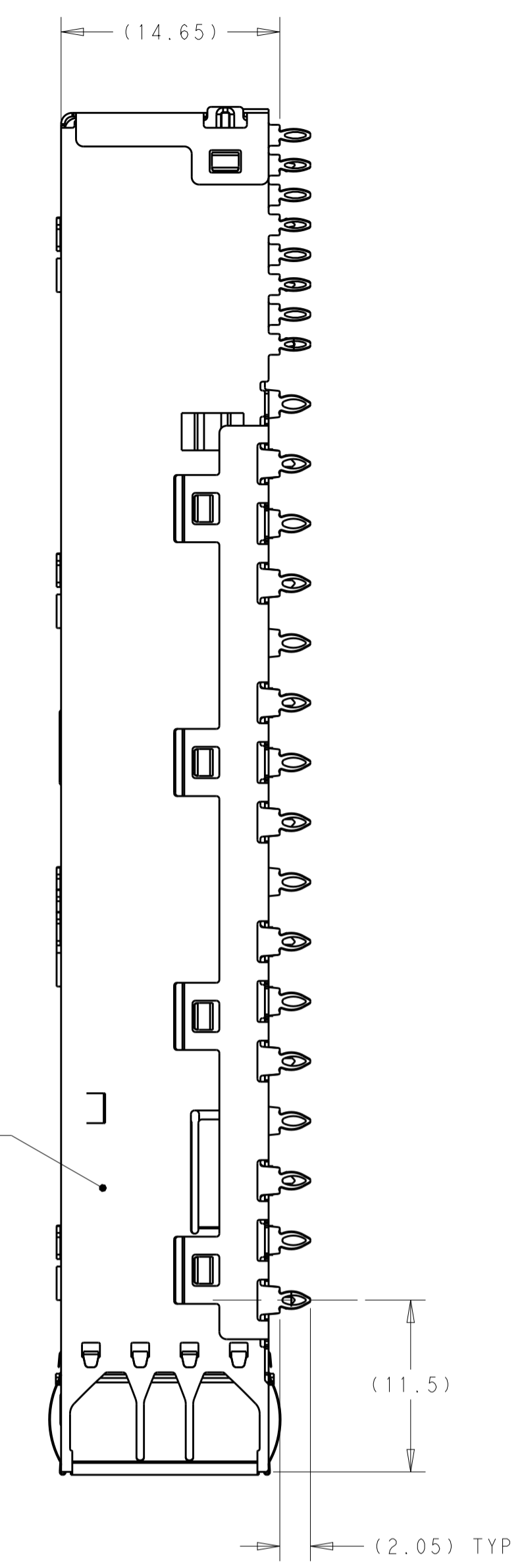

- 1 CAGE ASSEMBLY- 0.25mm THICK STAINLESS STEEL.
EMI SPRING- COPPER ALLOY.
LIGHT PIPE- CLEAR POLYCARBONATE.
LIGHT PIPE ORGANIZER- POLYCARBONATE.
LIGHT PIPE BRACKET- STAINLESS STEEL.
- 2 FINISH:
EMI SPRING- 1.27um NICKEL PLATING OVER ALL.
- 3. MATES WITH OSFP MSA COMPLIANT TRANSCEIVERS.
- 4 DATUM AND BASIC DIMENSION ESTABLISHED BY CUSTOMER.
- 5. MINIMUM PC BOARD THICKNESS:
SINGLE SIDE = 1.5MM
DOUBLE SIDE = 2.10MM
- 6 PADS AND VIAS CHASSIS GROUND.
- 7 REFERENCE APPLICATION SPEC 114-XXXX, HOLE A, FOR RECOMMENDED DRILL HOLE DIAMETER AND PLATING THICKNESS.
- 8 DATE CODE MARKED IN APPROXIMATE AREA.
- 9 LIGHT PIPE ASSEMBLY SHOWN ASSEMBLED TO CAGE ASSEMBLY FOR REFERENCE. LIGHT PIPE ASSEMBLY IS SHIPPED UNASSEMBLED FROM CAGE ASSEMBLY.
- 10 LED PLACEMENT AREA FOR 4 LIGHT PIPE DASH NUMBERS.
- 11 LED PLACEMENT AREA FOR 2 LIGHT PIPE DASH NUMBERS.
- 12 LED PLACEMENT AREA FOR 1 LIGHT PIPE DASH NUMBERS.
- 13 ASSEMBLY NOT COMPATIBLE WITH LIGHT PIPES.
- 14 ASSEMBLY COMPATIBLE WITH LIGHT PIPES.
- 15 PART NUMBER MARKED IN APPROXIMATE AREA.

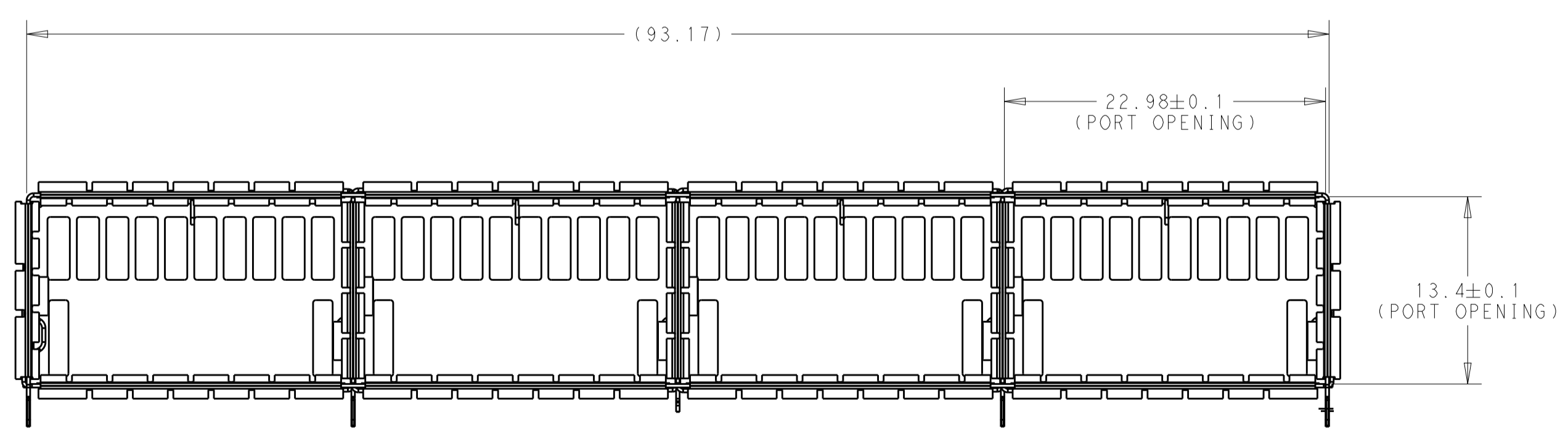

OBSOLETE	DESCRIPTION	PART NUMBER
4	WITH EMI SPRINGS	4-2315853-3
4	WITH EMI SPRINGS	4-2315853-1
2	WITH EMI SPRINGS	2-2315853-3
2	WITH EMI SPRINGS	2-2315853-1
1	WITH EMI SPRINGS	1-2315853-3
1	WITH EMI SPRINGS	1-2315853-1
14	WITH EMI SPRINGS	2315853-5
13	WITHOUT EMI SPRINGS	2315853-4
OBSOLETE	13 0 WITH EMI SPRINGS	2315853-3
OBSOLETE	13 0 WITHOUT EMI SPRINGS	2315853-2
OBSOLETE	13 0 WITH EMI SPRINGS	2315853-1
	LIGHT PIPES PER PORT	

THIS DRAWING IS A CONTROLLED DOCUMENT. OWN: ANDY XIE 07MAR2017
 CHK: SEAN HAN 07MAR2017
 APVD: SEAN HAN 07MAR2017

STE TE Connectivity

NAME: CAGE ASSEMBLY, 1X4, OSFP
 PRODUCT SPEC: 108-60117
 APPLICATION SPEC: 114-130009

SIZE: A1 CAGE CODE: - DRAWING NO: C=2315853
 WEIGHT: -
 CUSTOMER DRAWING

SCALE: 3:1 SHEET 1 OF 7 REV F

REVISIONS				
P.	LTN.	DESCRIPTION	DATE	OWN. APVD.
-	-	SEE SHEET 1	-	-

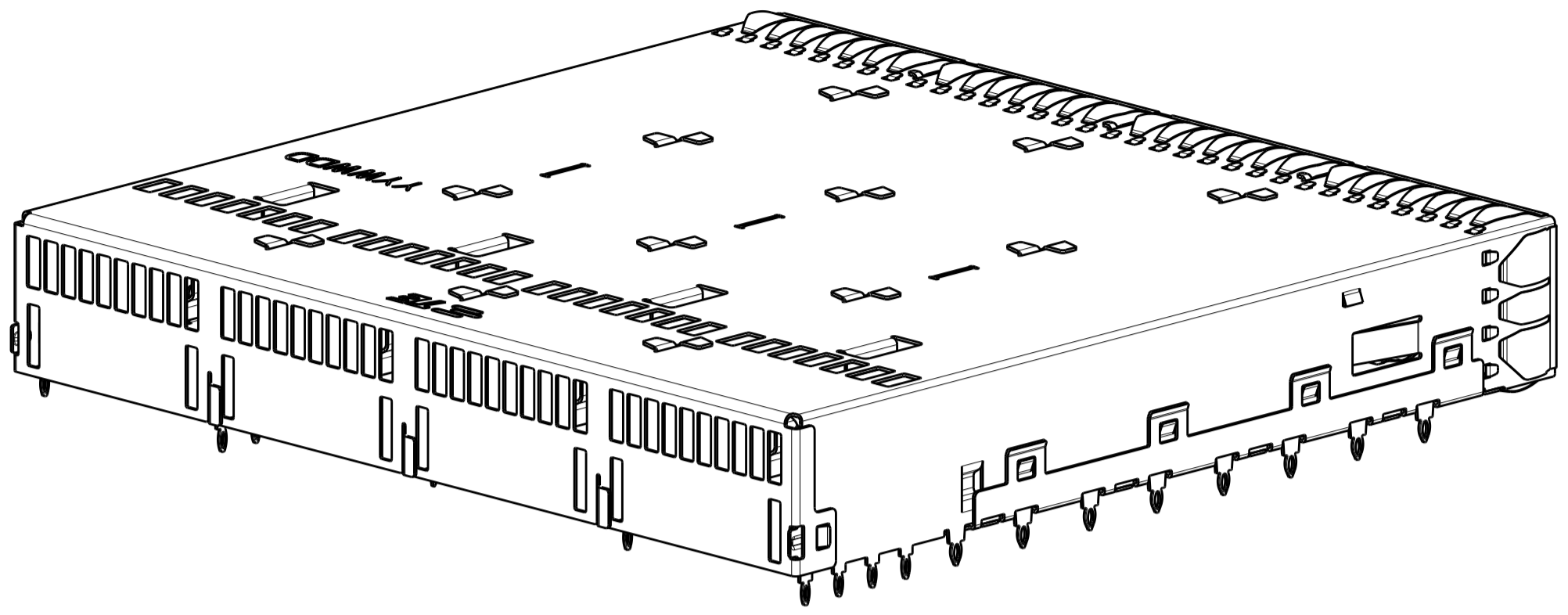

2315853-1
SCALE 2:1

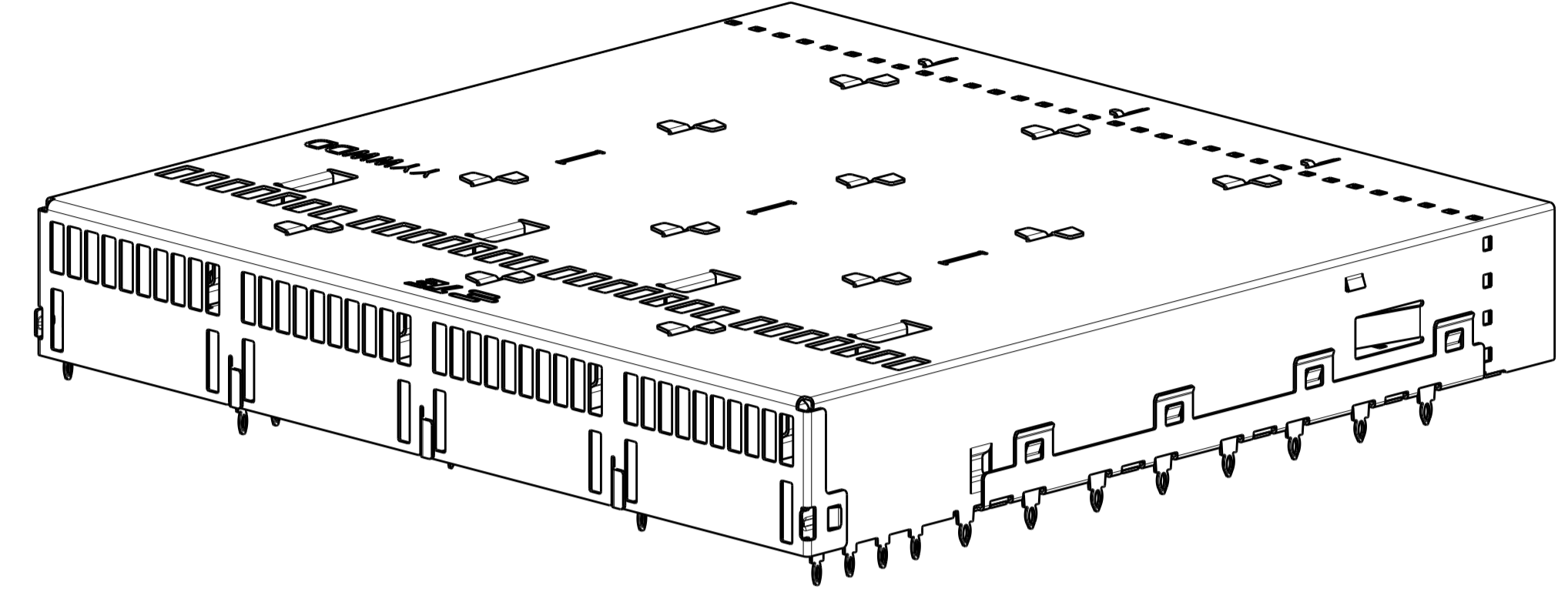

2315853-2
SCALE 2:1

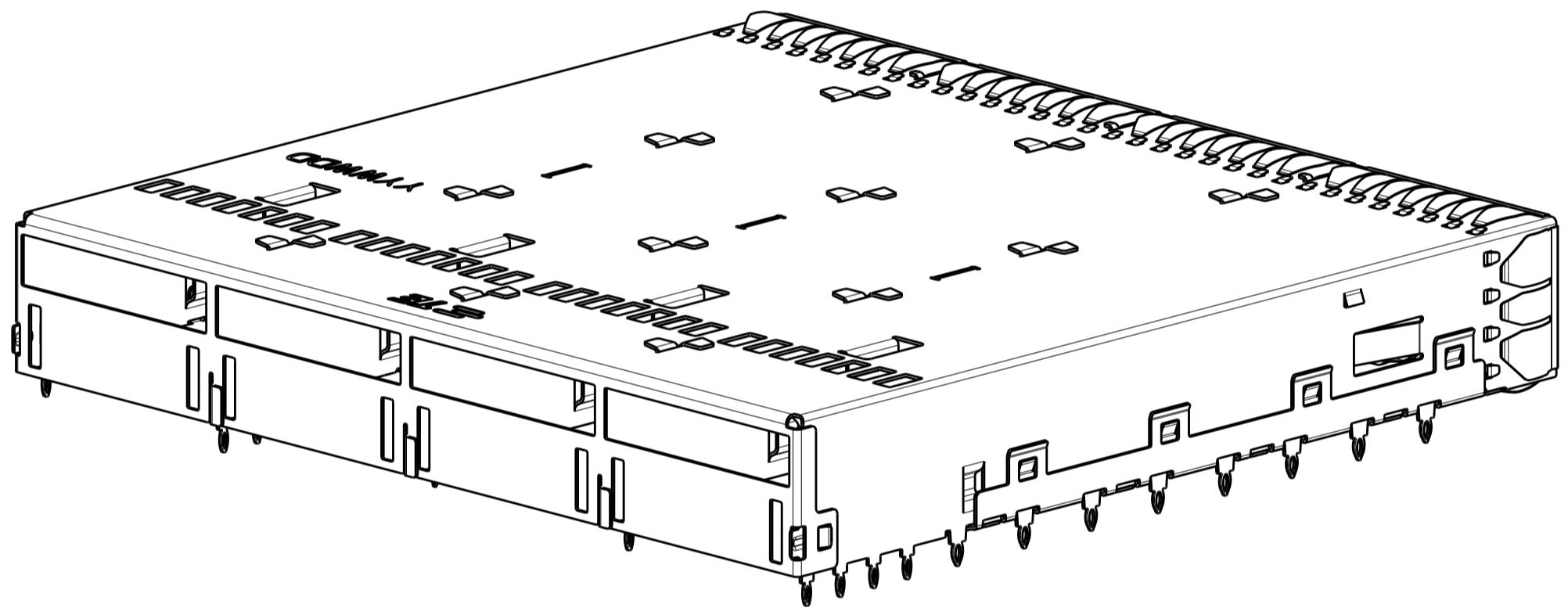

2315853-3
SCALE 2:1

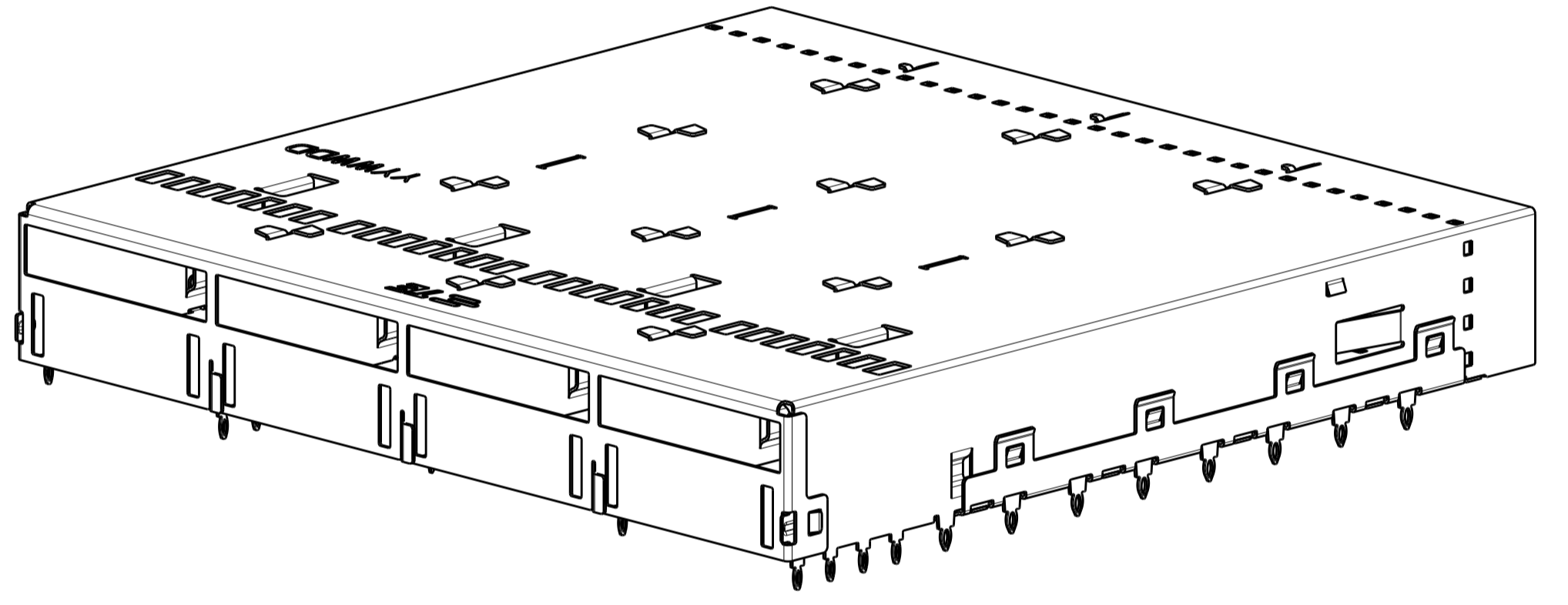

2315853-4
SCALE 2:1

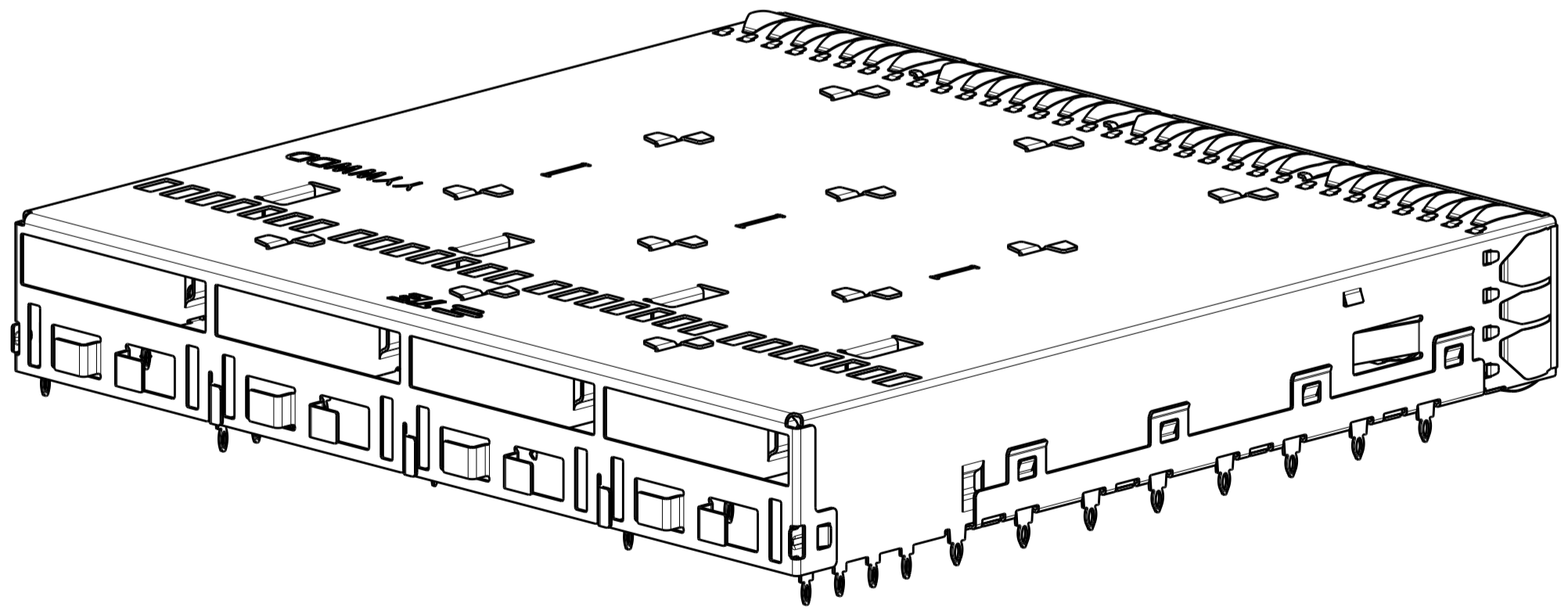

2315853-5
SCALE 2:1

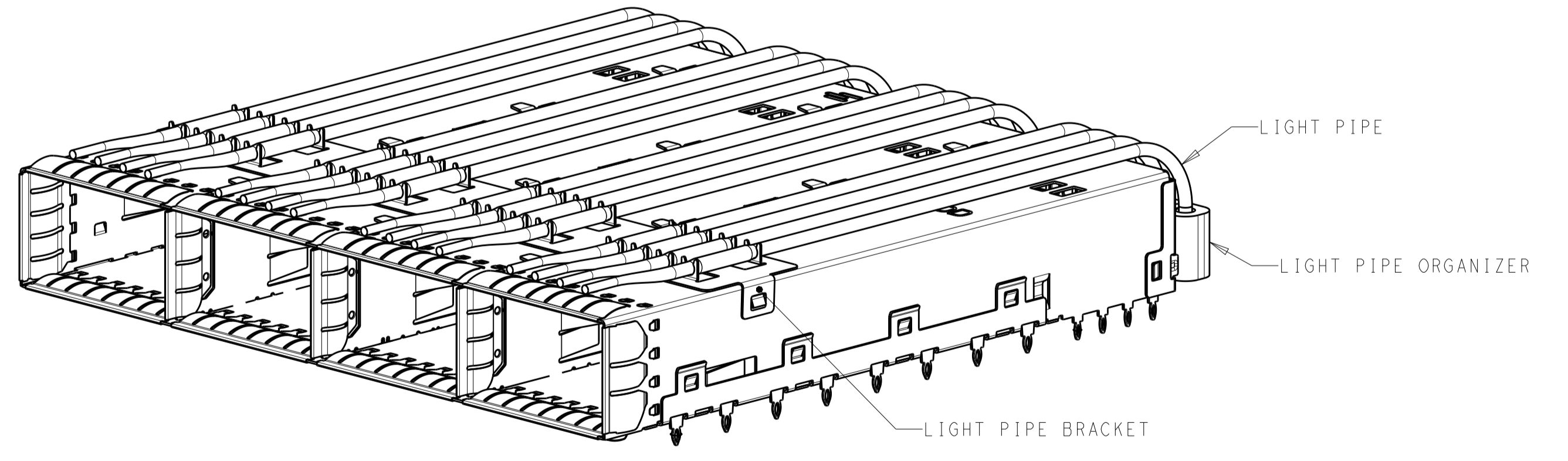

4-2315853-1 AND 4-2315853-3
SCALE 2:1

THIS DRAWING IS A CONTROLLED DOCUMENT.		OWN: ANDY XIE 07MAR2017	TE Connectivity
DIMENSIONS: mm		CHK: SEAN HAN 07MAR2017	
TOLERANCES UNLESS OTHERWISE SPECIFIED:		APVD: SEAN HAN 07MAR2017	NAME: CAGE ASSEMBLY, 1X4, OSFP
0 PLC ±0.25	1 PLC ±0.15	PRODUCT SPEC: 108-60117	SIZE: A1
3 PLC ±0.10	4 PLC ±0.10	APPLICATION SPEC: 114-130009	CAGE CODE: C=2315853
ANGLES ±0.10	FINISH	WEIGHT	RESTRICTED TO: -
MATERIAL		CUSTOMER DRAWING	SCALE: 3:1 SHEET 2 OF 7 REV F

REVISIONS				
P.	LTN	DESCRIPTION	DATE	OWN APVD
-	-	SEE SHEET 1	-	-

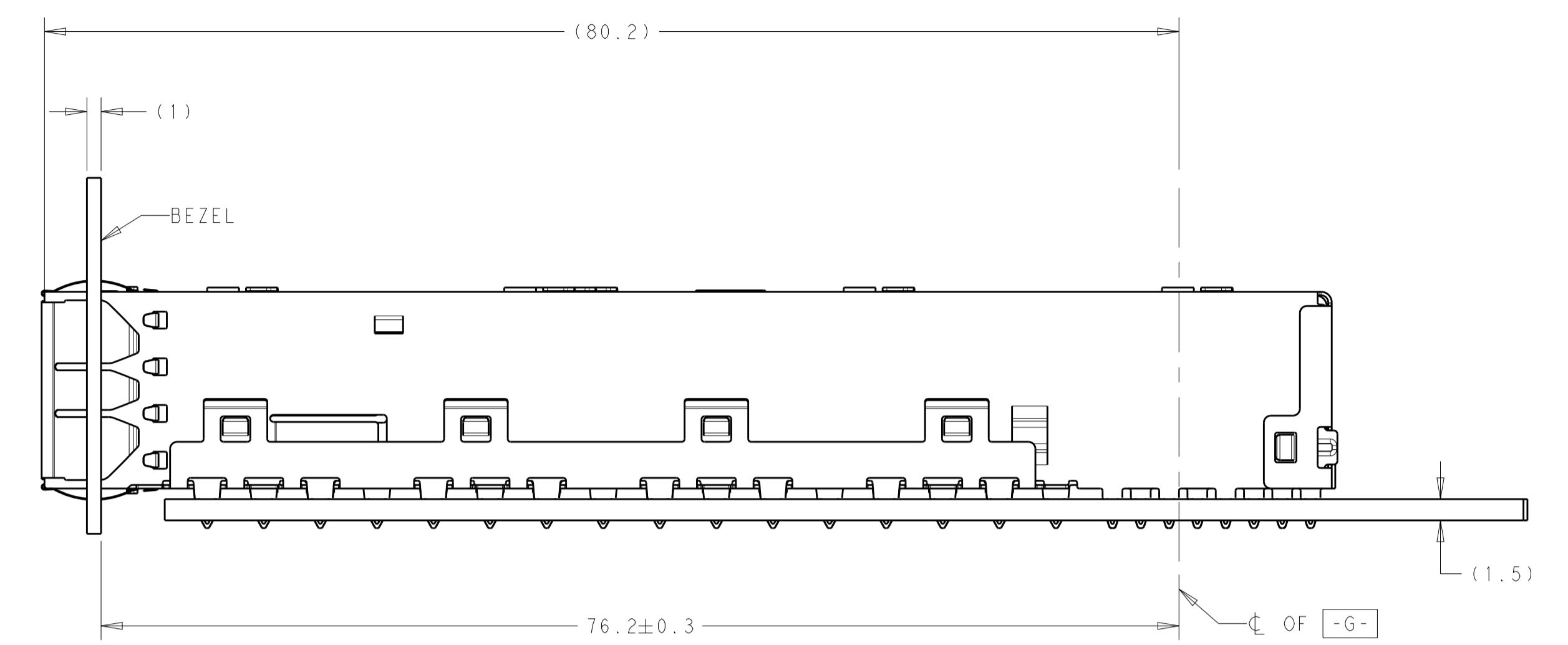
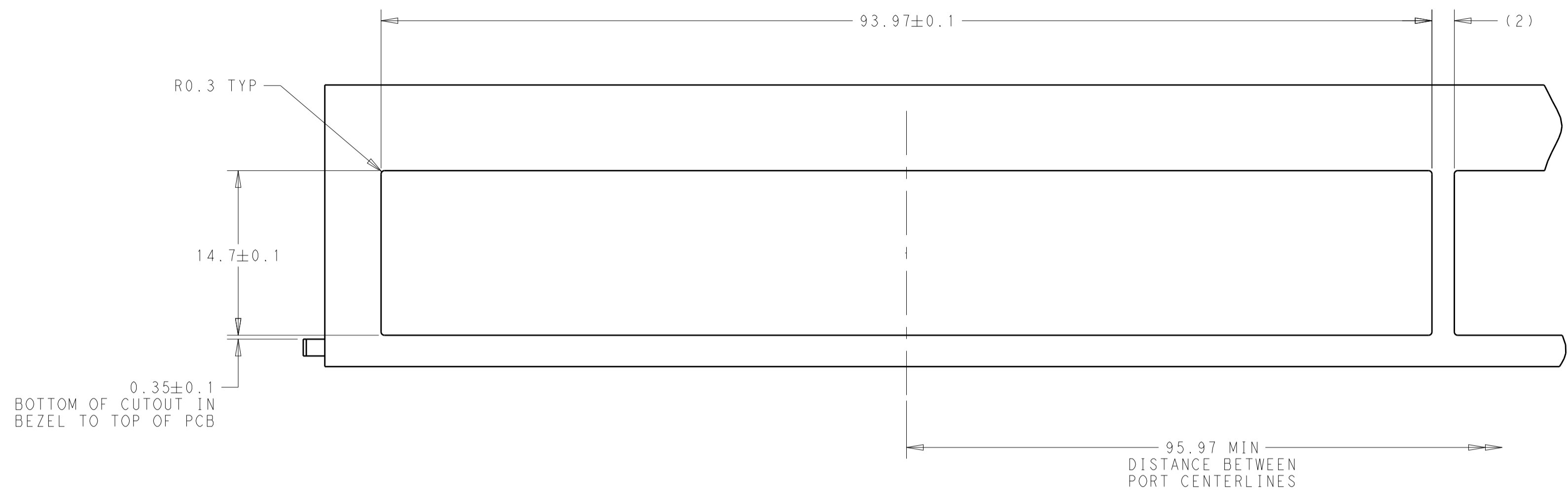

SINGLE SIDE MOUNTING

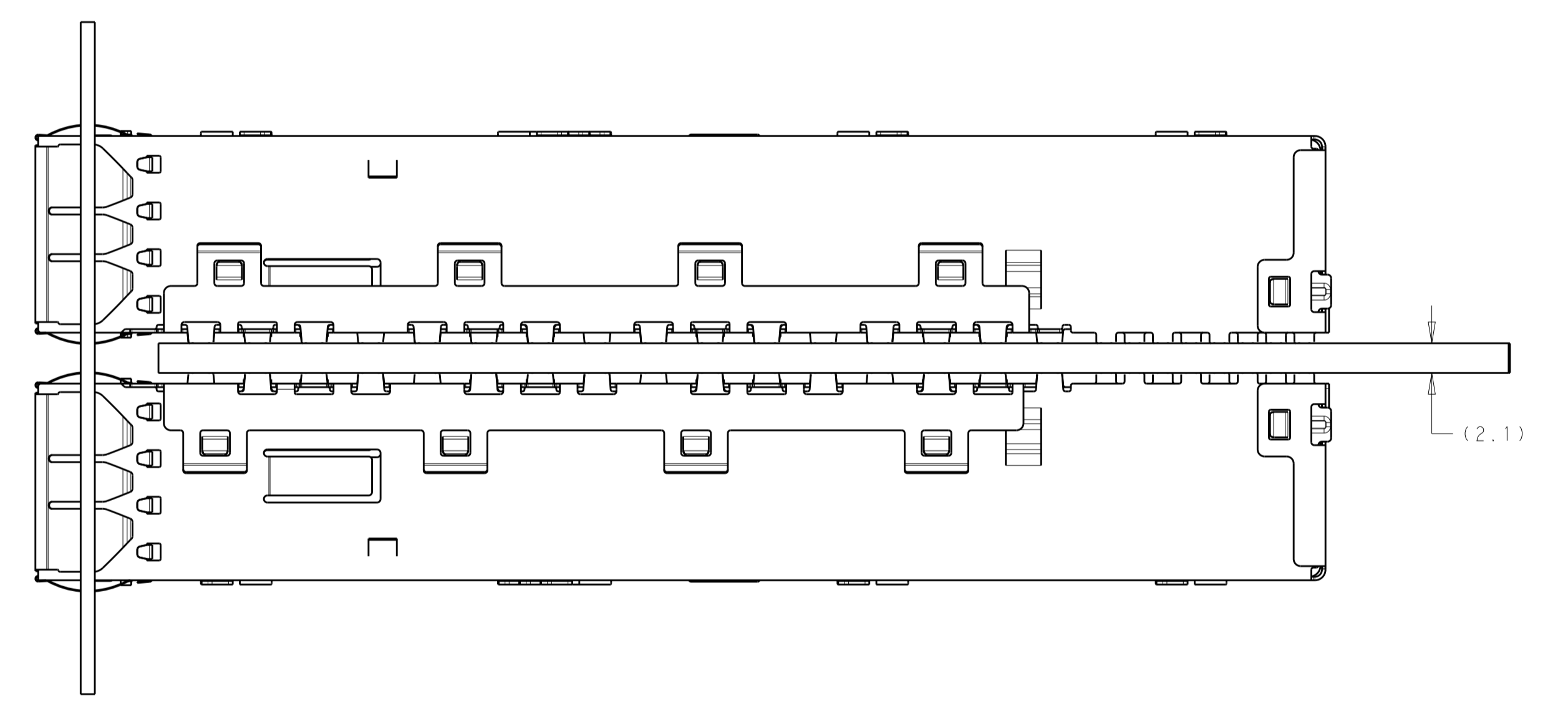
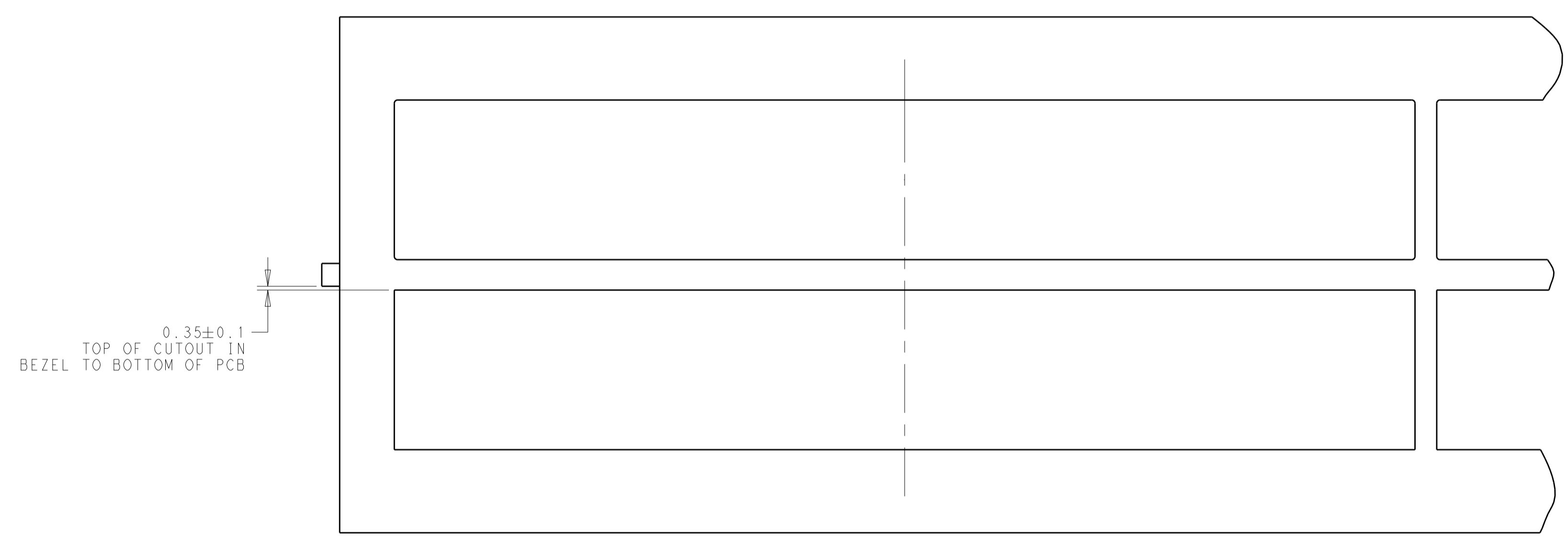

BELLY TO BELLY MOUNTING
 SAME AS SINGLE SIDE
 EXCEPT AS NOTED

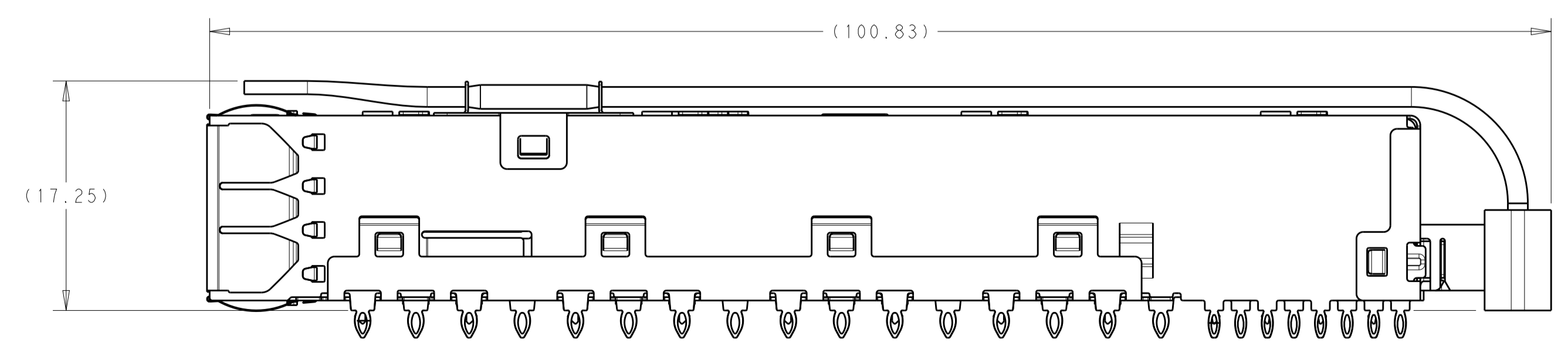

THIS DRAWING IS A CONTROLLED DOCUMENT.		OWN: ANDY XIE 07MAR2017	TE Connectivity
DIMENSIONS: mm		CHK: SEAN HAN 07MAR2017	
TOLERANCES UNLESS OTHERWISE SPECIFIED:		APVD: SEAN HAN 07MAR2017	NAME: CAGE ASSEMBLY, 1X4, OSFP
0 PLC ±	1 PLC ±0.25	PRODUCT SPEC	SIZE: A1
2 PLC ±0.15	3 PLC ±0.10	APPLICATION SPEC	CAGE CODE: -
4 PLC ±	ANGLES ±	114-130009	DRAWING NO: C=2315853
MATERIAL: -	FINISH: -	WEIGHT: -	RESTRICTED TO: -
CUSTOMER DRAWING			SCALE: 3:1 SHEET 3 OF 7 REV F

REVISIONS				
P.	LTH	DESCRIPTION	DATE	APVD
-	-	SEE SHEET 1	-	-

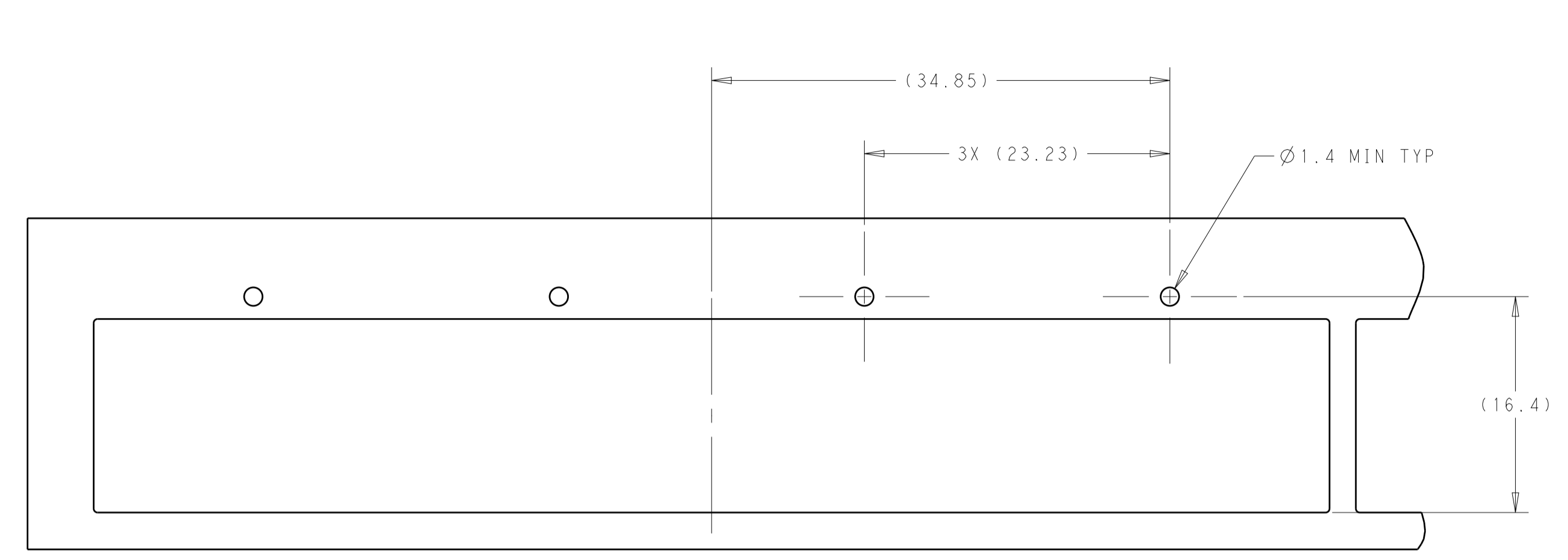

BEZEL LAYOUT FOR SINGLE LIGHT PIPE
SINGLE SIDE

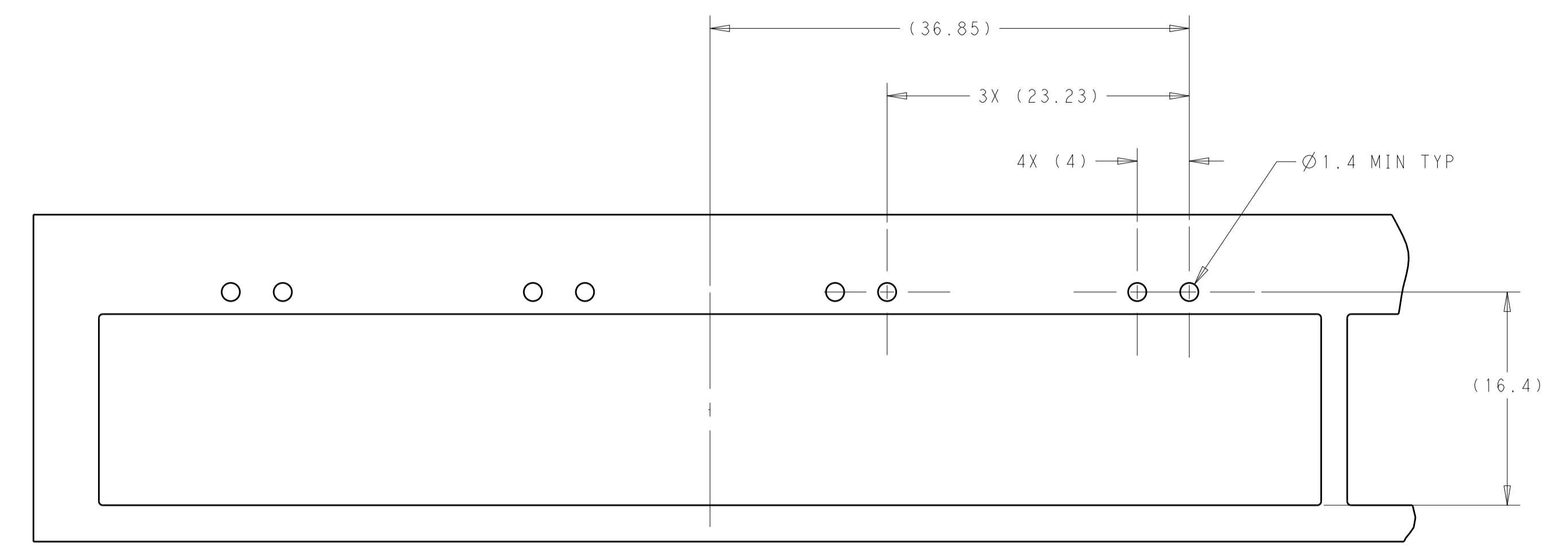

BEZEL LAYOUT FOR DOUBLE LIGHT PIPE
SINGLE SIDE

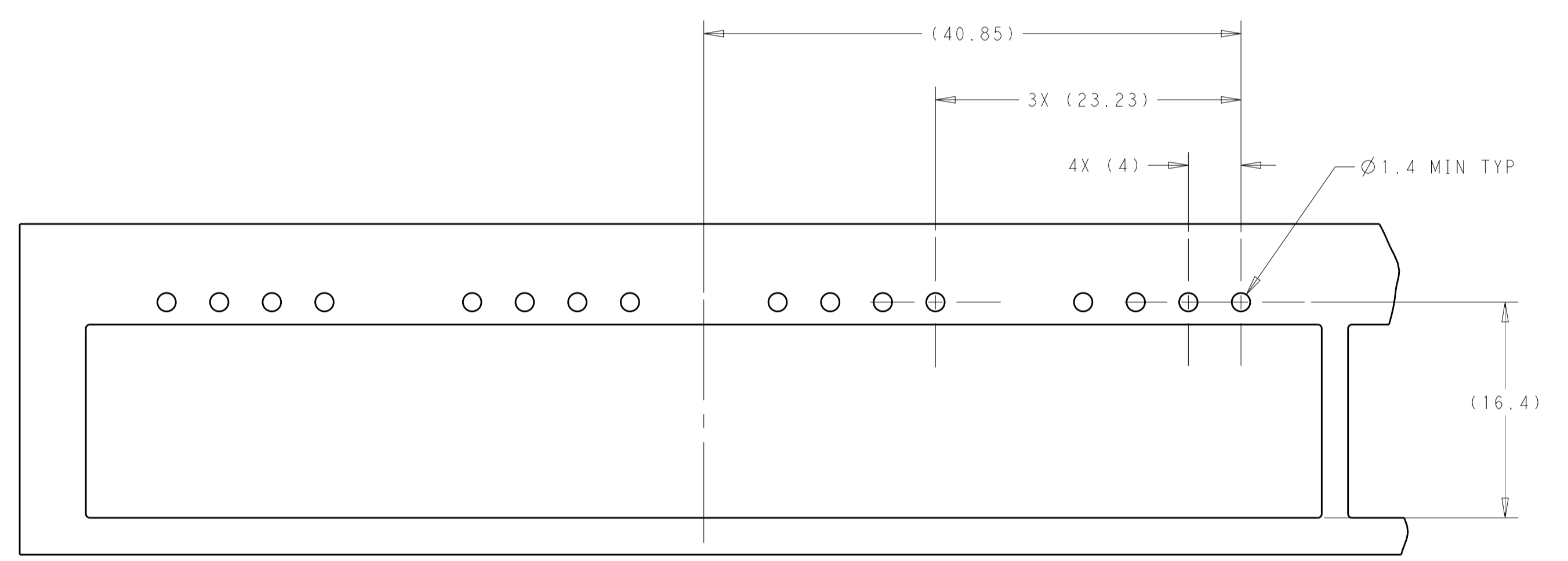

BEZEL LAYOUT FOR QUAD LIGHT PIPE
SINGLE SIDE

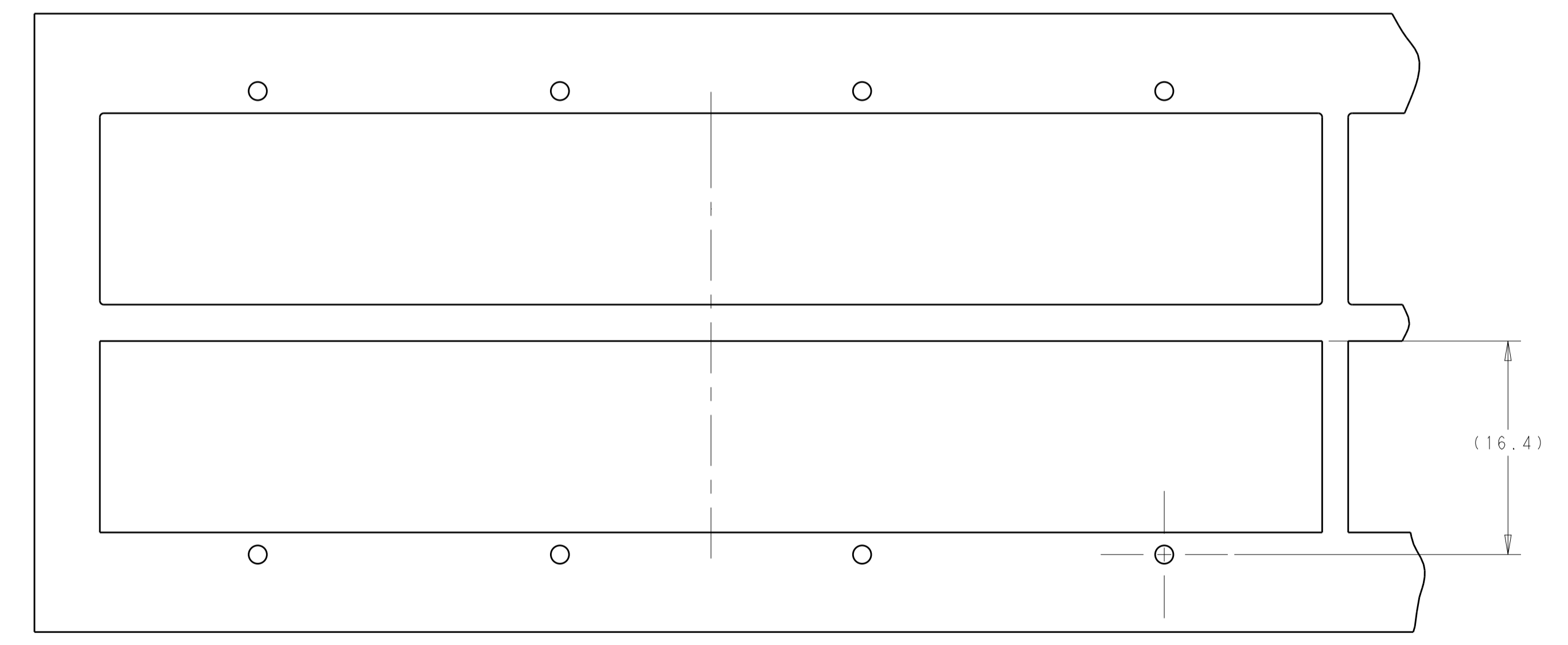

BEZEL LAYOUT FOR LIGHT PIPES
BELLY TO BELLY
SIMILAR TO SINGLE SIDE
EXCEPT WHERE NOTED

THIS DRAWING IS A CONTROLLED DOCUMENT.		OWN: ANDY XIE 07MAR2017	TE Connectivity
DIMENSIONS: mm		CHK: SEAN HAN 07MAR2017	
TOLERANCES UNLESS OTHERWISE SPECIFIED:		APVD: SEAN HAN 07MAR2017	NAME: CAGE ASSEMBLY, 1X4, OSFP
0 PLC ±0.25	1 PLC ±0.15	PRODUCT SPEC: 108-60117	SIZE: A1
2 PLC ±0.10	3 PLC ±0.10	APPLICATION SPEC: 114-130009	CAGE CODE: -
4 PLC ±0.10	ANGLES ±0.10	WEIGHT: -	DRAWING NO: C=2315853
MATERIAL: -	FINISH: -	CUSTOMER DRAWING	RESTRICTED TO: -
SCALE: 3:1		SHEET 4 OF 7 REV F	

REVISIONS				
P.	LTN	DESCRIPTION	DATE	APVD
-	-	SEE SHEET 1	-	-

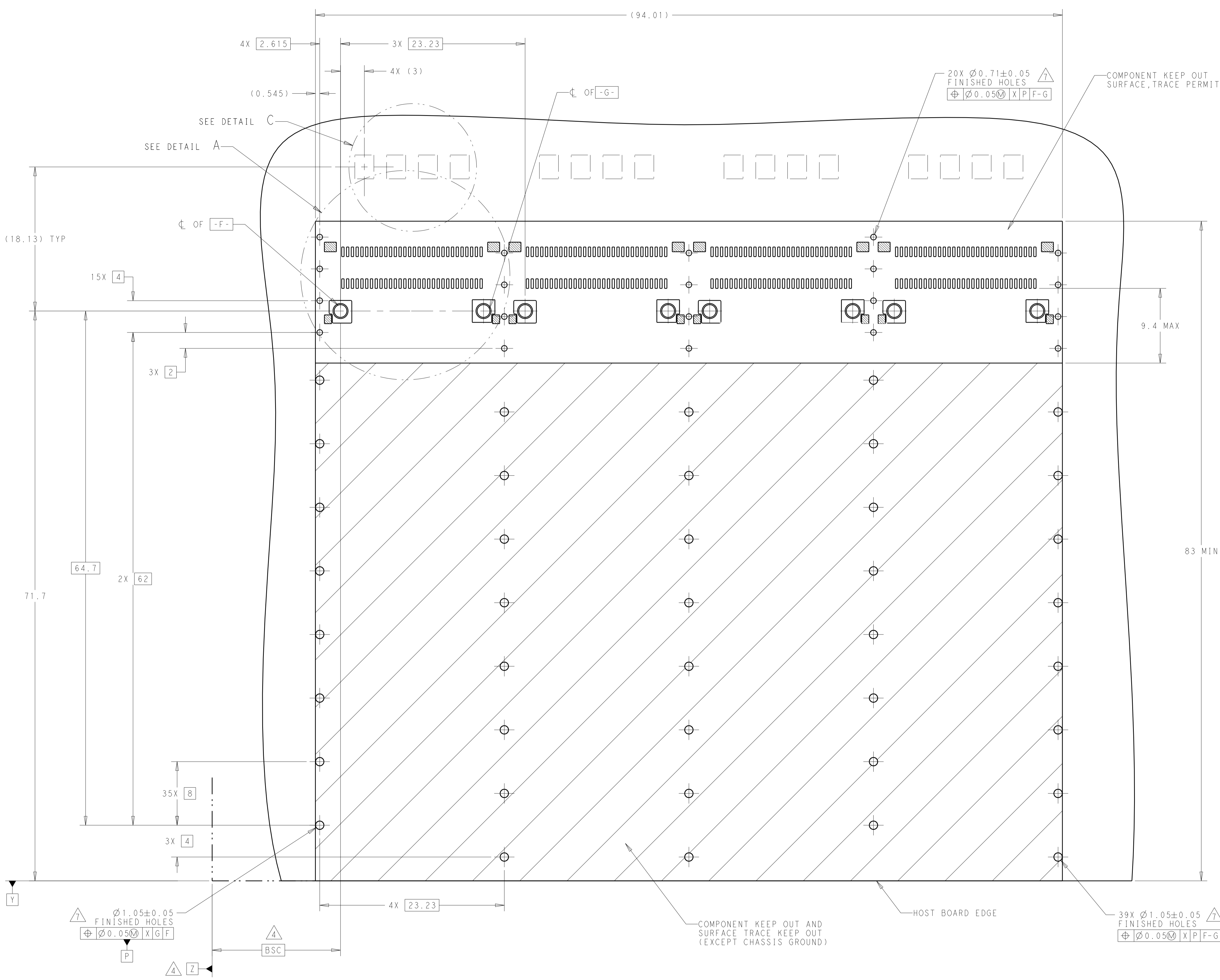

RECOMMENDED PCB LAYOUT
SINGLE SIDED APPLICATION
SCALE 4:1

THIS DRAWING IS A CONTROLLED DOCUMENT.		OWN: ANDY XIE 07MAR2017	 TE Connectivity
DIMENSIONS: mm		CHK: SEAN HAN 07MAR2017	
TOLERANCES UNLESS OTHERWISE SPECIFIED:		APVD: SEAN HAN 07MAR2017	NAME: CAGE ASSEMBLY, 1X4, OSFP
0 PLC	±0.25	PRODUCT SPEC	SIZE: A1
2 PLC	±0.15	108-60117	CAGE CODE: -
3 PLC	±0.10	APPLICATION SPEC	DRAWING NO: C=2315853
4 PLC	±0.10	114-130009	RESTRICTED TO: -
ANGLES	±0.10	WEIGHT: -	SCALE: 3:1
MATERIAL: -	FINISH: -	CUSTOMER DRAWING	SHEET 5 of 7
			REV F

REVISIONS				
P.	LTN.	DESCRIPTION	DATE	OWN. APVD.
-	-	SEE SHEET 1	-	-

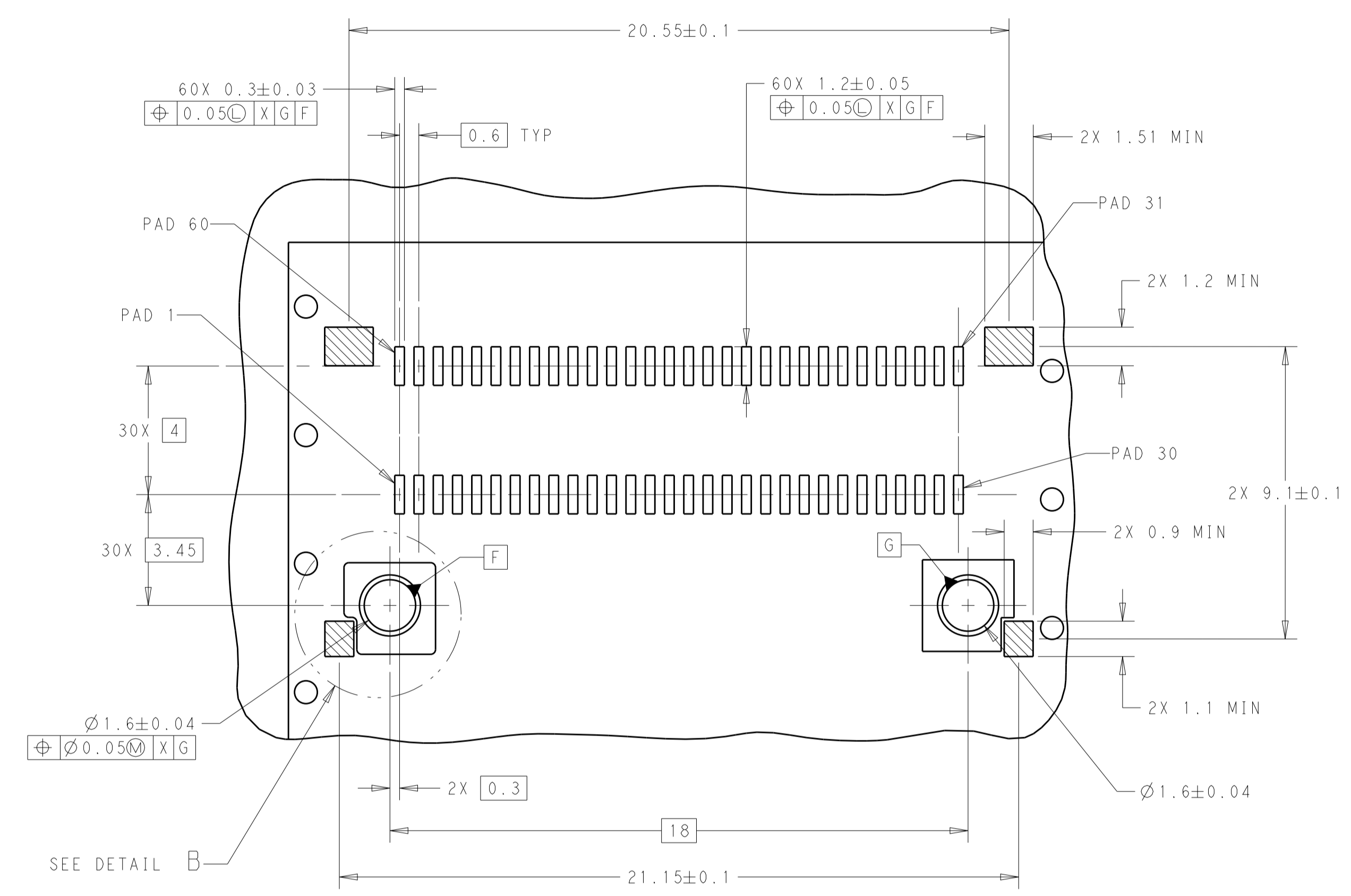

4X INDIVIDUALLY
 DETAIL A
 SCALE 8:1

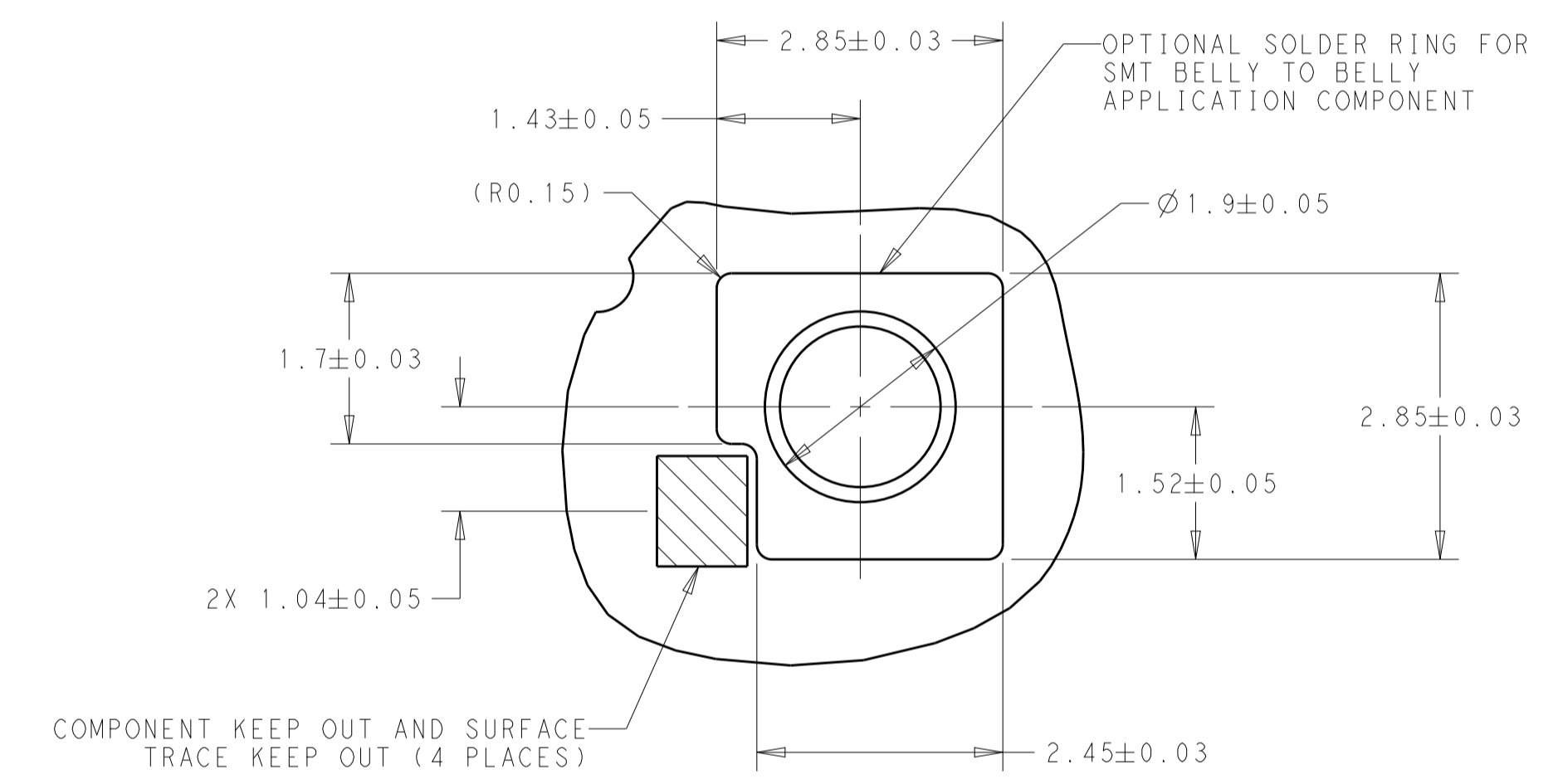

DETAIL B
 SCALE 16:1

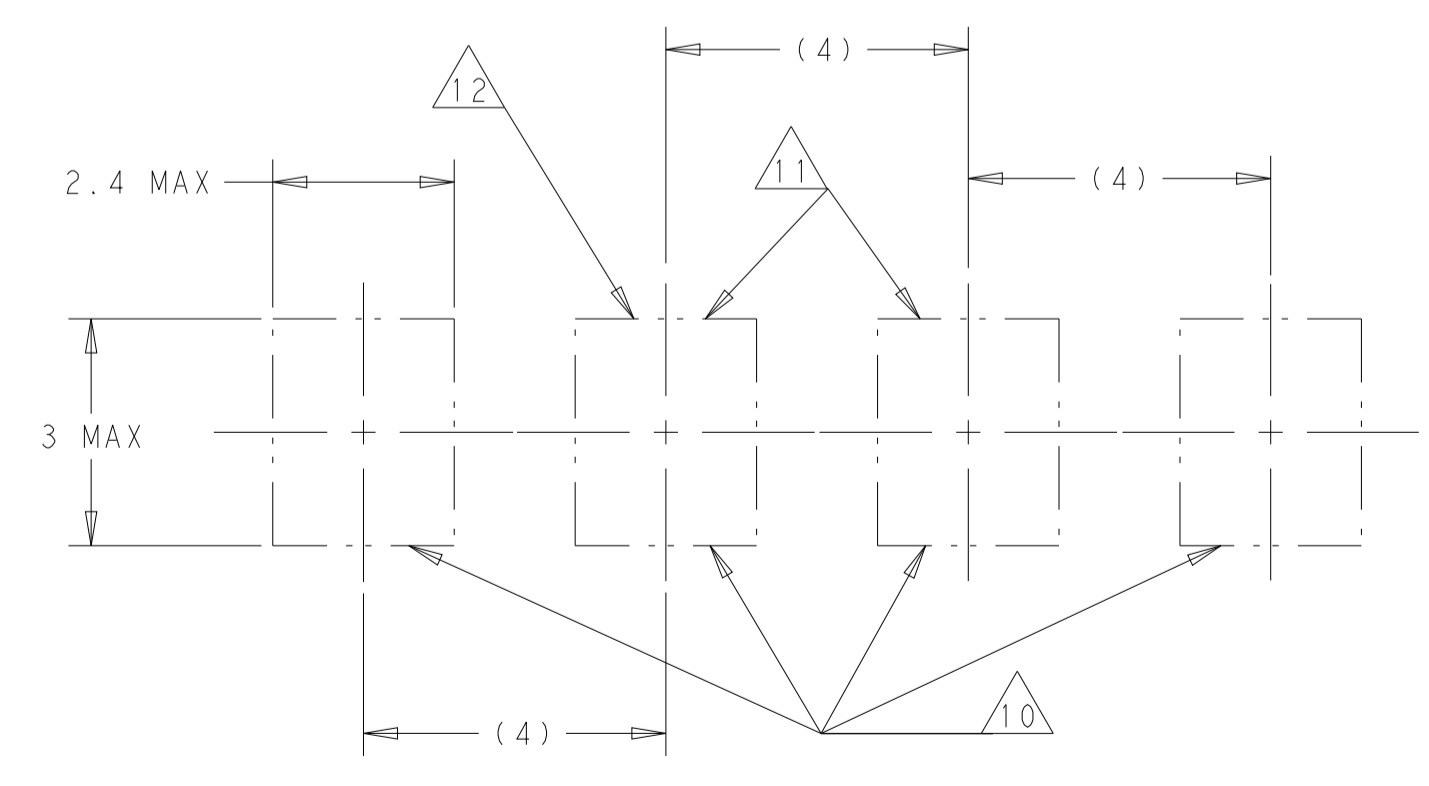

DETAIL C
 SCALE 10:1

THIS DRAWING IS A CONTROLLED DOCUMENT.		OWN: ANDY XIE 07MAR2017	TE Connectivity
DIMENSIONS: mm		CHK: SEAN HAN 07MAR2017	
TOLERANCES UNLESS OTHERWISE SPECIFIED:		APVD: SEAN HAN 07MAR2017	NAME: CAGE ASSEMBLY, 1X4, OSFP
0 PLC ±	1 PLC ±0.25	PRODUCT SPEC	SIZE: A1
2 PLC ±0.15	3 PLC ±0.10	108-60117	CAGE CODE: -
4 PLC ±	ANGLES ±	APPLICATION SPEC	DRAWING NO: -
MATERIAL: -	FINISH: -	114-130009	RESTRICTED TO: -
CUSTOMER DRAWING		WEIGHT: -	SCALE: 3:1
		114-130009	SHEET: 6 OF 7
		©=2315853	REV: F

REVISIONS				
P.	LTH	DESCRIPTION	DATE	APVD
-	-	SEE SHEET 1	-	-

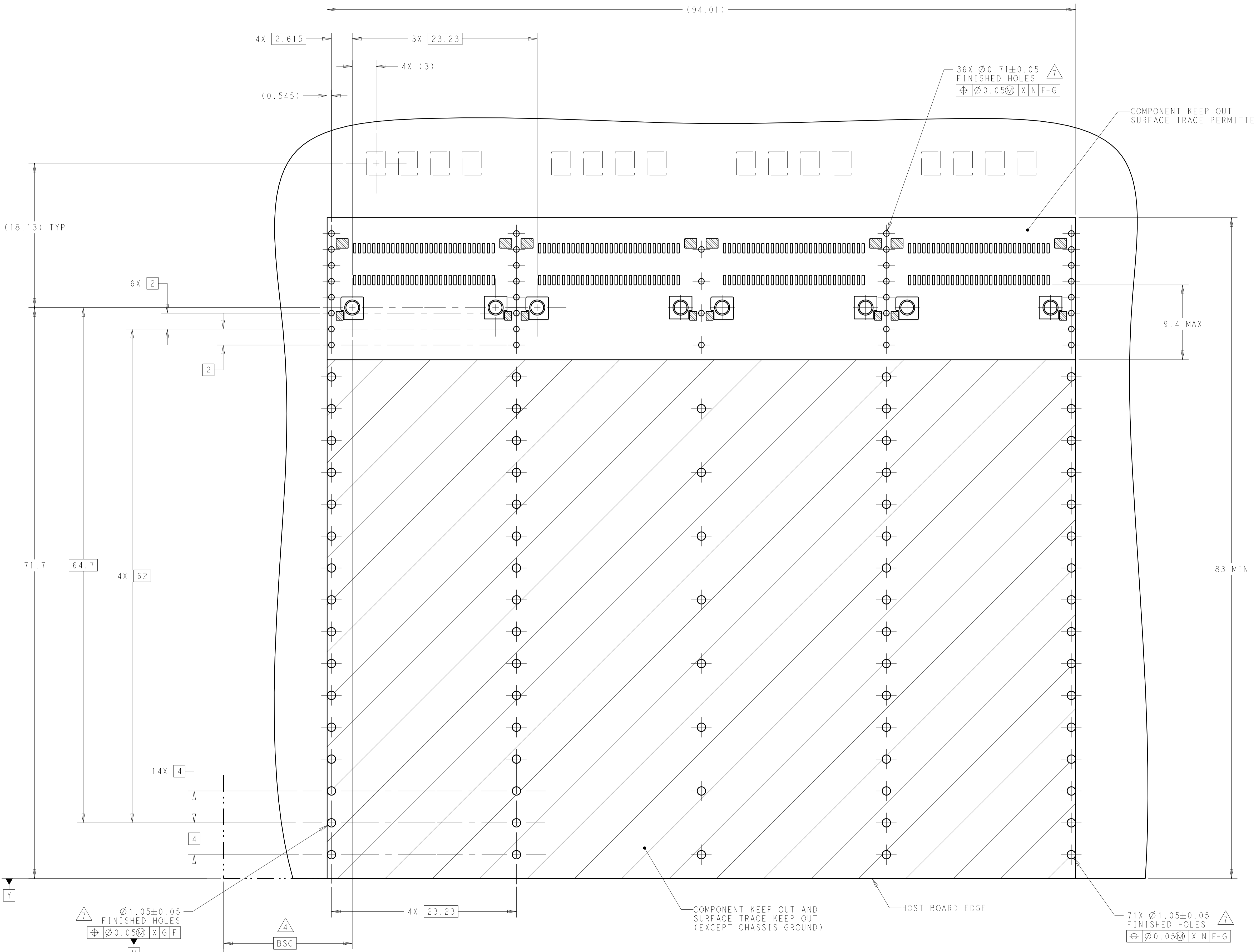

RECOMMENDED PCB LAYOUT
BELLY TO BELLY APPLICATION
SCALE 4:1

THIS DRAWING IS A CONTROLLED DOCUMENT.		OWN: ANDY XIE 07MAR2017	TE Connectivity
DIMENSIONS: mm		CHK: SEAN HAN 07MAR2017	
TOLERANCES UNLESS OTHERWISE SPECIFIED:		APVD: SEAN HAN 07MAR2017	NAME: CAGE ASSEMBLY, 1X4, OSFP
0 PLC	±0.25	PRODUCT SPEC	SIZE: A1
2 PLC	±0.15	APPLICATION SPEC	CAGE CODE: -
3 PLC	±0.10	114-130009	DRAWING NO: C=2315853
4 PLC	±0.05	114-130009	RESTRICTED TO: -
ANGLES	±0.10	WEIGHT: -	SCALE: 3:1
MATERIAL: -	FINISH: -	CUSTOMER DRAWING	SHEET 7 OF 7
			REV: F

单击下面可查看定价，库存，交付和生命周期等信息

[>>TE Connectivity\(泰科\)](#)