

THIS DRAWING IS UNPUBLISHED. RELEASED FOR PUBLICATION  
 © COPYRIGHT - By - ALL RIGHTS RESERVED.

LOC		DIST		REVISIONS			
P	LTR	DESCRIPTION		DATE	DWN	APVD	
CM	00	F4		REVISED PER ECO-11-004820	11MAR11	RK HMR	

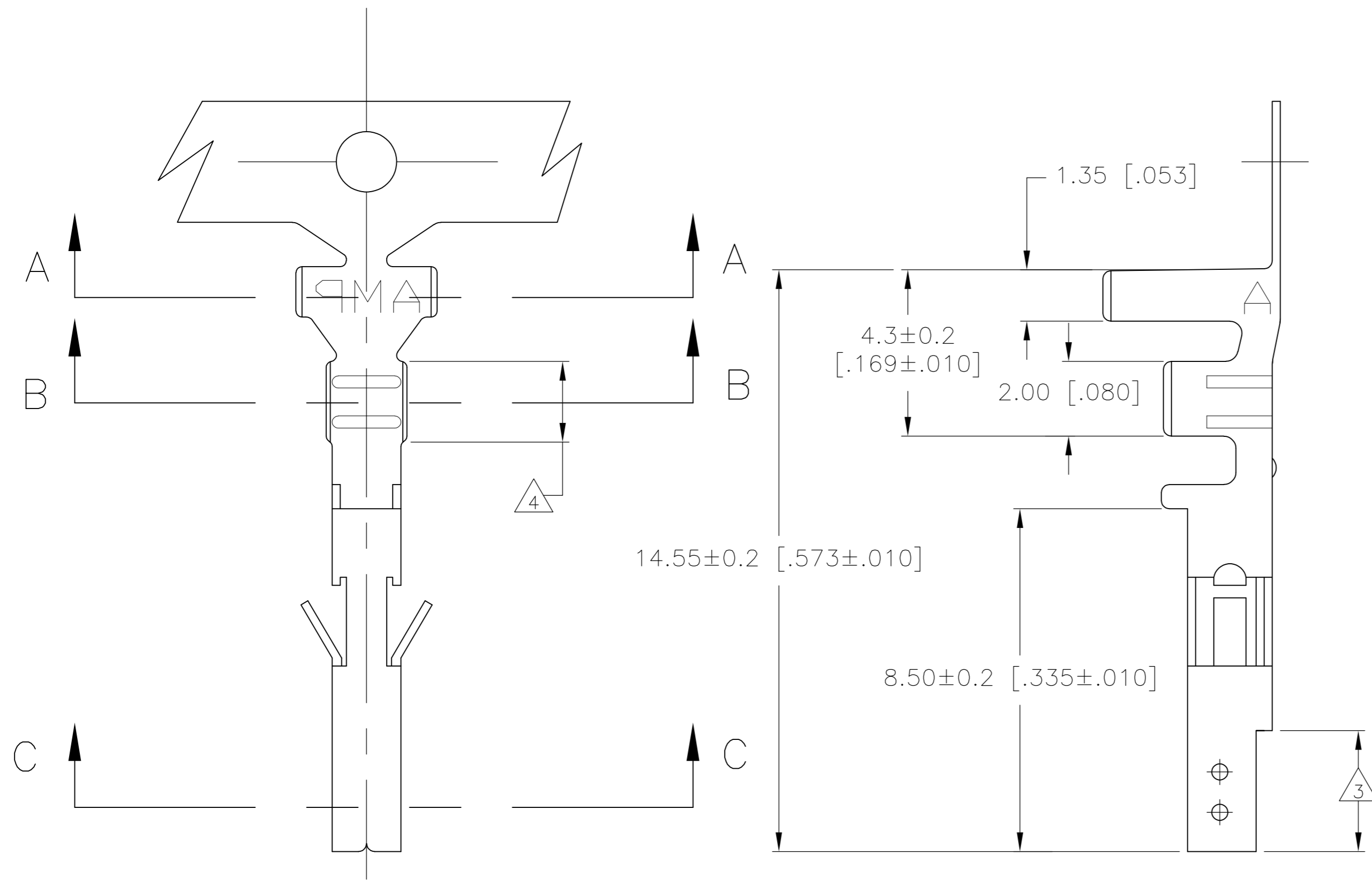

- 1 WIRE RANGE: 0.13–0.32mm<sup>2</sup> (26–22 AWG).
- 2 INSULATION RANGE: 1.20–1.75 DIA.
- 3 FINISH: 0.76 MIN GOLD OVER 1.27μm MIN NICKEL REQUIRED ON INNER SURFACE, PERMITTED ON OUTER SURFACE.
- 4 FINISH: 2.54μm MIN PRE-TIN ON ALL SURFACES IN THIS AREA.
- 5 FINISH: 2.54μm MINIMUM PRE-TIN ALL OVER.

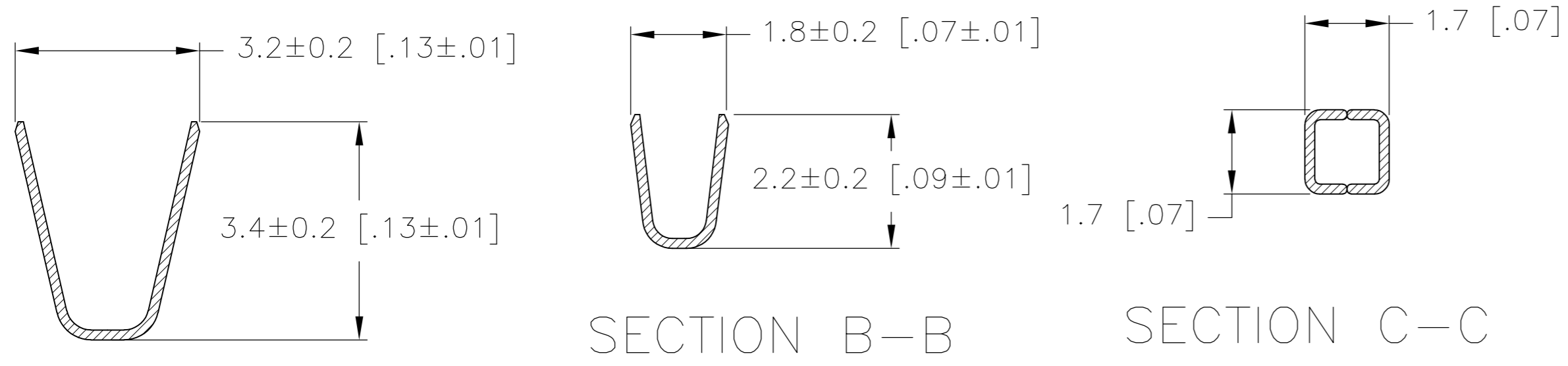

GOLD	3 4	PHOS. BRZ.	794958-4
PRE-TIN	5	PHOS. BRZ.	794958-3
GOLD	3 4	BRASS	794958-2
PRE-TIN	5	BRASS	794958-1
FINISH:		MATERIAL:	PART NO.

THIS DRAWING IS A CONTROLLED DOCUMENT.		DWN	10-SEP-2001	TE Connectivity	
DIMENSIONS: mm [INCHES]		S. HAMM	10-SEP-2001	NAME: S. HAMM	
TOLERANCES UNLESS OTHERWISE SPECIFIED:		D. COLEY	10-SEP-2001		
0 PLC ±		APVD	10-SEP-2001	NAME: D. COLEY	
1 PLC ± 0.15 [.006]		D. COLEY	10-SEP-2001		
2 PLC ± 0.10 [.004]		PRODUCT SPEC		TERMINAL SOCKET VAL-U-LOK(TM)	
3 PLC ± 0.050 [.0020]		APPLICATION SPEC		SIZE	CAGE CODE
4 PLC ±				A2	00779
ANGLES ±				DRAWING NO	RESTRICTED TO
FINISH				C=794958	-
MATERIAL		WEIGHT		SCALE	SHEET
				10:1	1 of 1
		CUSTOMER DRAWING		REV	F4

**METRIC**

单击下面可查看定价，库存，交付和生命周期等信息

[>>TE Connectivity\(泰科\)](#)