

THIS DRAWING IS UNPUBLISHED. RELEASED FOR PUBLICATION  
 © COPYRIGHT - By TYCO ELECTRONICS CORPORATION. ALL RIGHTS RESERVED.

LOC	DIST	REVISIONS			
P	LTR	DESCRIPTION	DATE	DWN	APVD
AF	50	F	REVISE PER ECR-13-013738	15FEB2014	GRZ JL

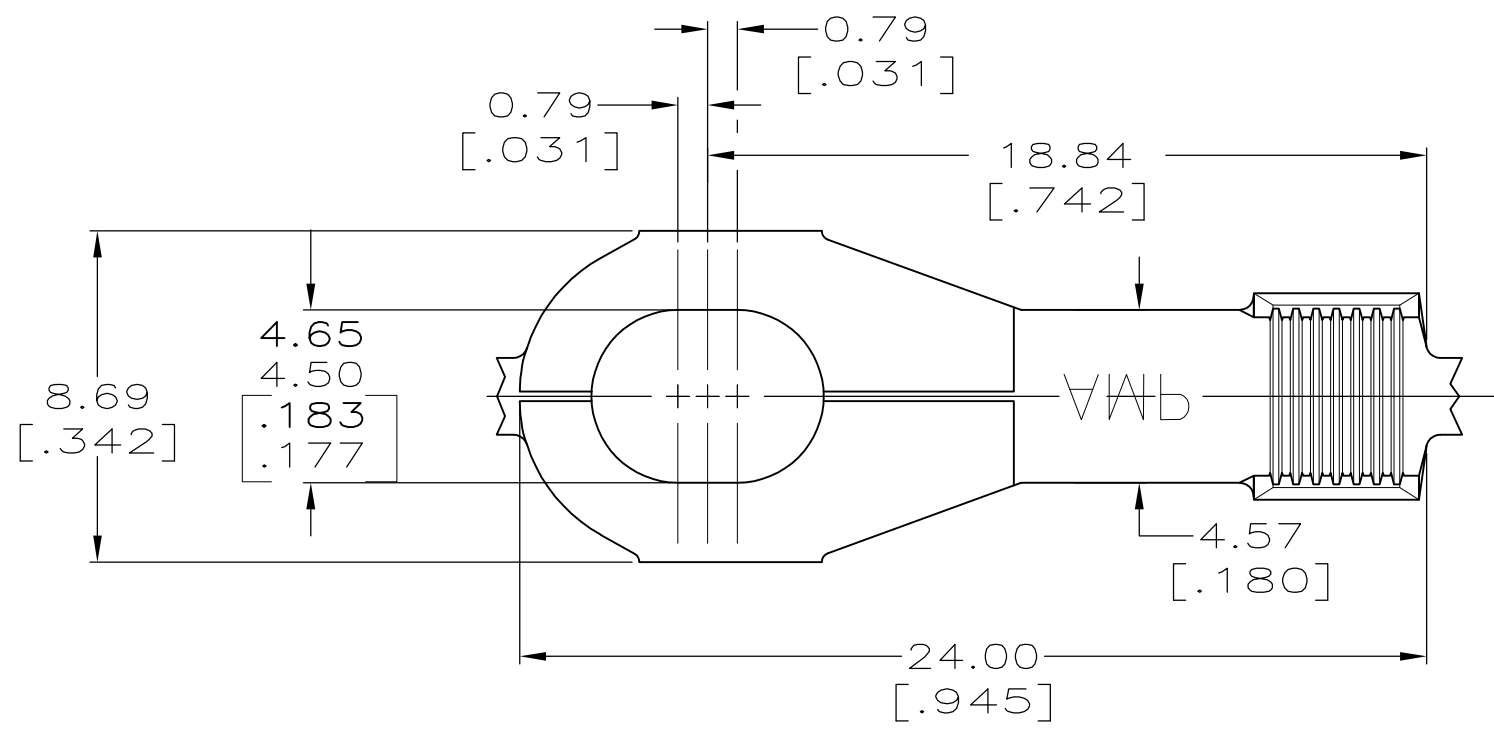

- 1 CONTINUOUS STRIP ON REEL.
- 2 SERRATION DETAIL APPLIES ONLY AT STRAIGHT PORTION ON SIDE OF BARREL.

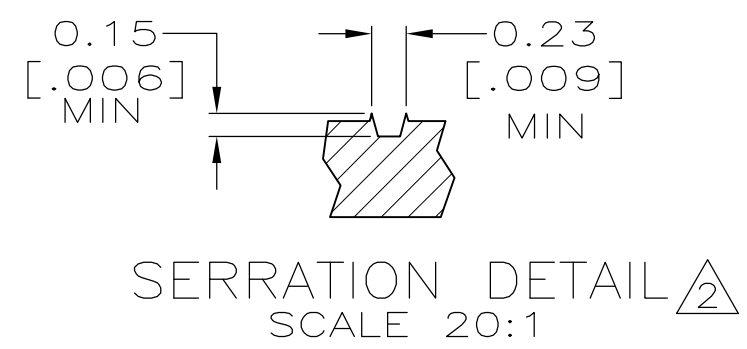
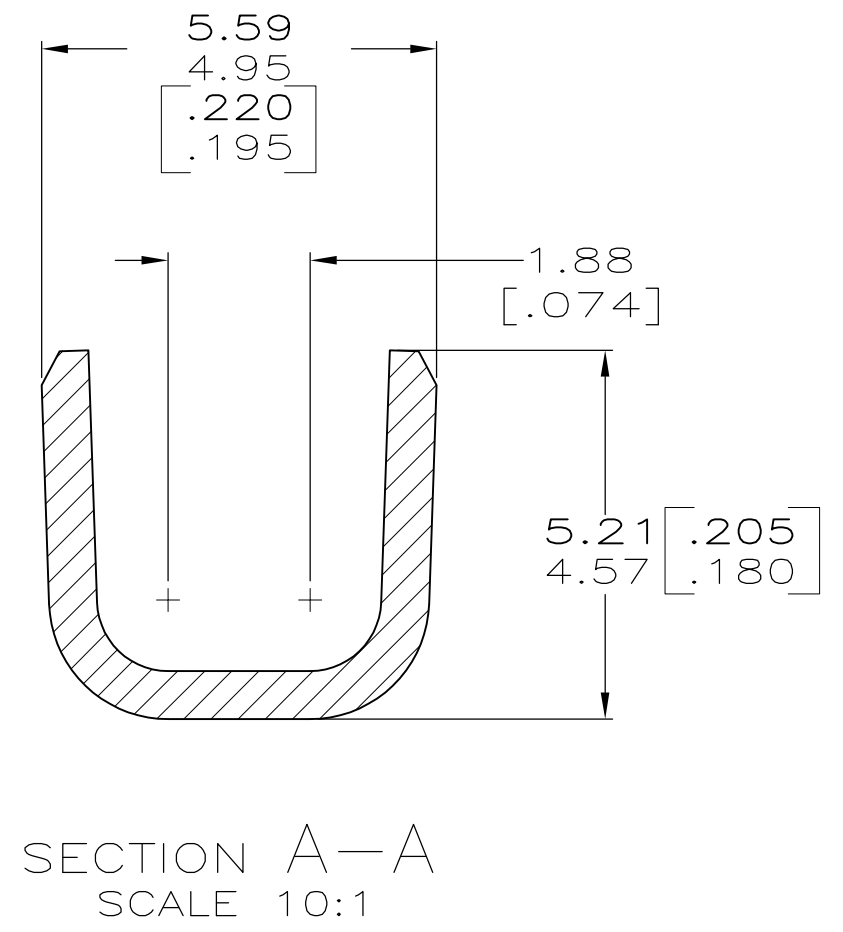
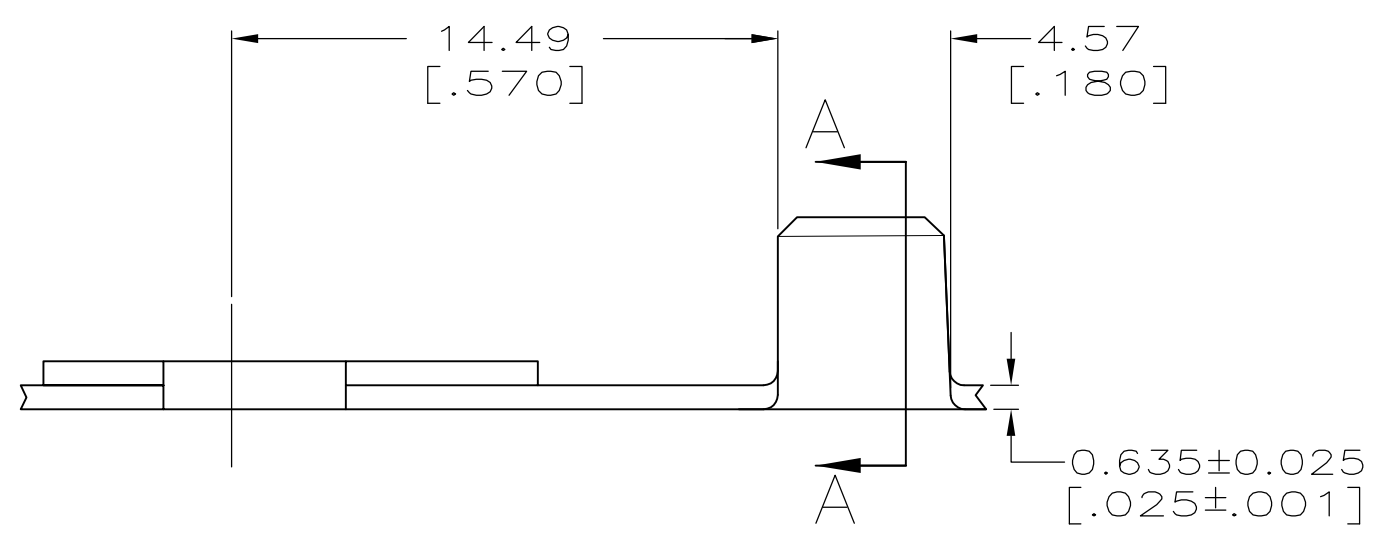

14-12 AWG OR (2) 15 AWG	62755-1
WIRE RANGE	PART NUMBER

THIS DRAWING IS A CONTROLLED DOCUMENT.		DWN 14APR1999 PHILLIP M FORTNEY	TE Connectivity	
DIMENSIONS: mm		CHK 14APR1999 JEFF R RUTH		
TOLERANCES UNLESS OTHERWISE SPECIFIED:		APVD 14APR1999 JEREMY DUNCAN	NAME RING,AMPLIVAR	
0 PLC ± -		PRODUCT SPEC	SIZE	
1 PLC ± -		APPLICATION SPEC	CAGE CODE	
2 PLC ± 0.25[.010]		WEIGHT	DRAWING NO	
3 PLC ± -		CUSTOMER DRAWING	RESTRICTED TO	
4 PLC ± -		SCALE 5:1	SHEET 1 OF 1	
ANGLES ± -		SCALE 5:1	REV F	
FINISH -		SCALE 5:1	REV F	
MATERIAL BRASS		SCALE 5:1	REV F	

单击下面可查看定价，库存，交付和生命周期等信息

[>>TE Connectivity\(泰科\)](#)