

		REVISIONS				LOC	DIST
P	F	ZONE	LTR	DESCRIPTION	DATE	APPROVED	
		F	REV PER	0600-6036-96	CT	10-97	GA

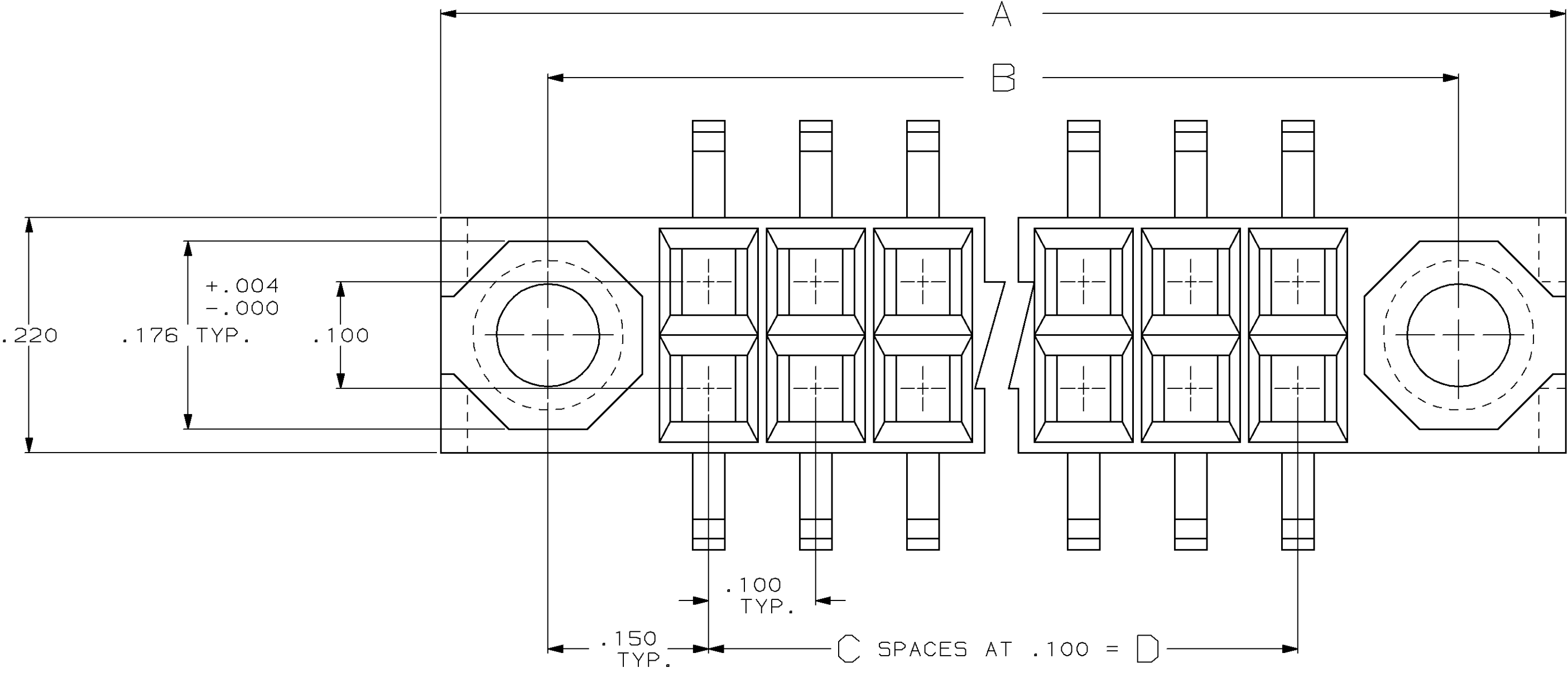

- △ HOUSING MATERIAL: POLYPHENYLENE SULFIDE, 40% GLASS
- △ CONTACT MATERIAL: PHOSPHOR BRONZE, TEMPER HARD, PER QQ-B-750, COMPOSITION: A.
- △ CONTACT FINISH: .000030 GOLD MIN. PER MIL-G-45204, TYPE II, CLASS 0, GRADE C, IN CONTACT AREA ONLY OVER .000050 MIN. NICKEL UNDERPLATE ALL OVER PER QQ-N-290, CLASS 1, GRADE N/A, GOLD FLASH OVER BALANCE OF CONTACT BOX STRUCTURE. .000300 MIN. REFLOWED TIN-LEAD ON SOLDER LEAD, PER MIL-P-81728.
- △ SOLDER LEAD FOOT FORM MUST PASS SOLDERABILITY PER MIL-STD-202, METHOD 208 E.
- △ GAS PLASMA CONDITION MOUNTING LUG TO CIRCUIT SURFACE FOR ADHESIVE RETENTION, PER PHILLIPS CHEMICAL TSM-283.

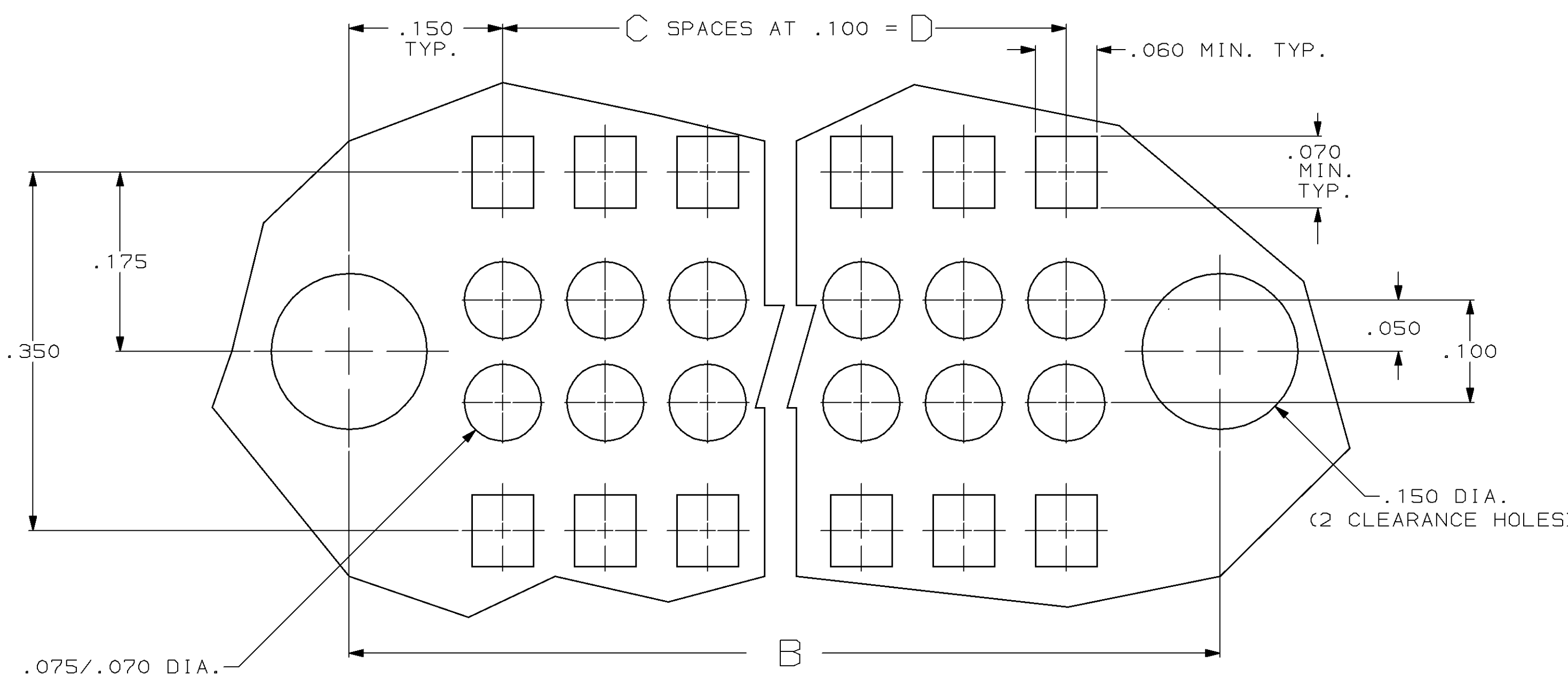
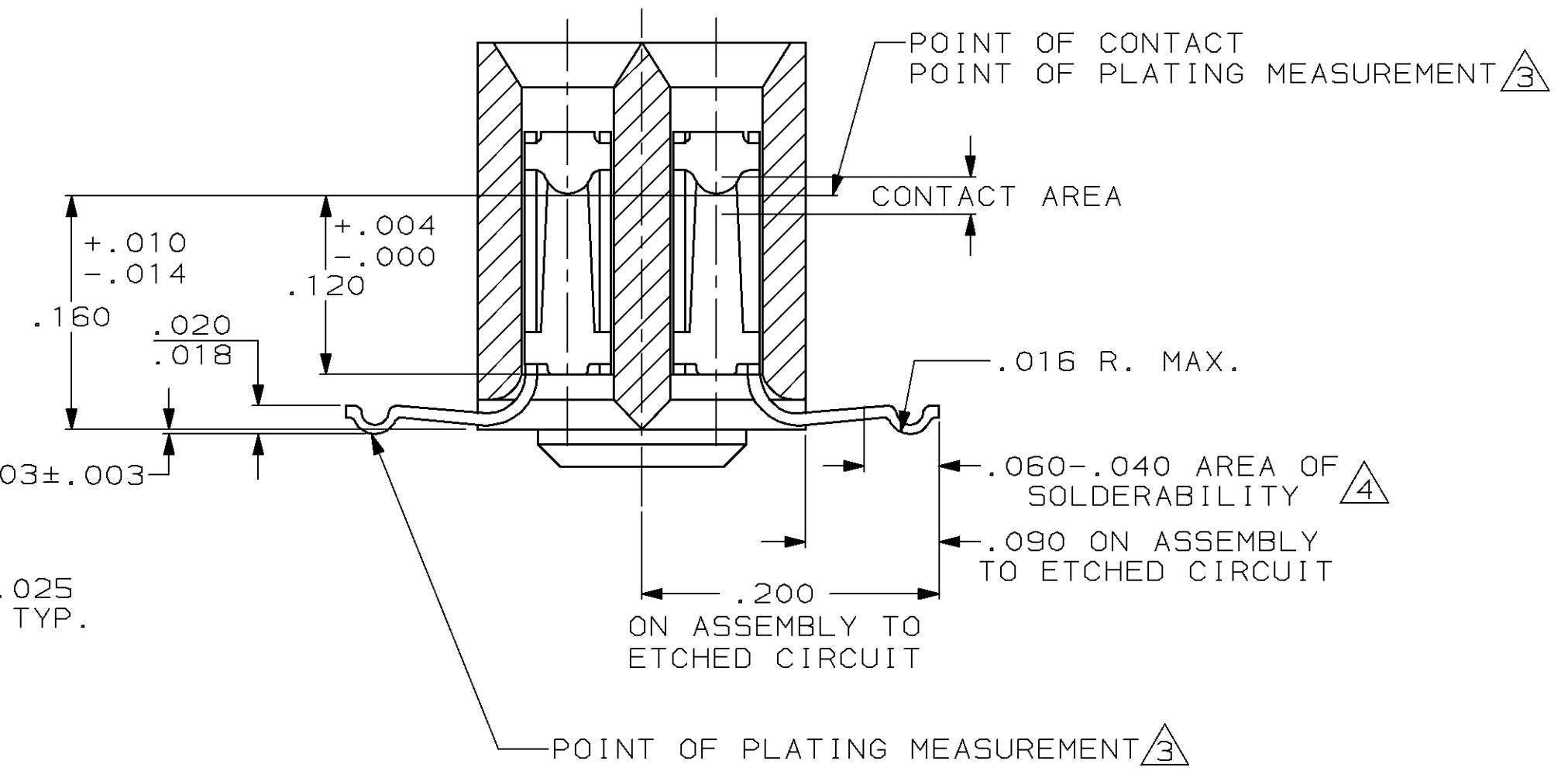
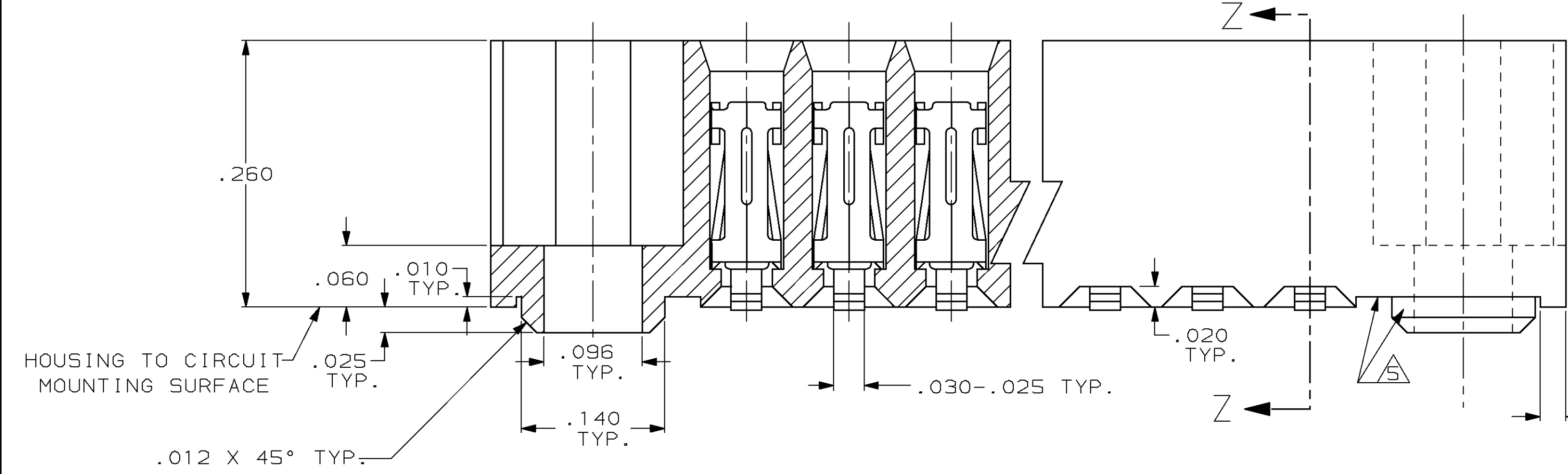

RECOMMENDED ETCHED CIRCUIT LAYOUT  
 DIMENSIONS & TOLERANCES IN ACCORDANCE WITH ANSI/IPC-D-300 G, TYPE 1, CLASS C

D	C	B	A	POS.	PART NUMBER
2.900	29	3.200	3.400	60	
2.800	28	3.100	3.300	58	
2.700	27	3.000	3.200	56	
2.600	26	2.900	3.100	54	
2.500	25	2.800	3.000	52	
2.400	24	2.700	2.900	50	
2.300	23	2.600	2.800	48	
2.200	22	2.500	2.700	46	
2.100	21	2.400	2.600	44	
2.000	20	2.300	2.500	42	
1.900	19	2.200	2.400	40	
1.800	18	2.100	2.300	38	
1.700	17	2.000	2.200	36	
1.600	16	1.900	2.100	34	
1.500	15	1.800	2.000	32	3034286-2
1.400	14	1.700	1.900	30	3034286-1
1.300	13	1.600	1.800	28	
1.200	12	1.500	1.700	26	534286-9
1.100	11	1.400	1.600	24	
1.000	10	1.300	1.500	22	
.900	9	1.200	1.400	20	
.800	8	1.100	1.300	18	
.700	7	1.000	1.200	16	
.600	6	.900	1.100	14	
.500	5	.800	1.000	12	
.400	4	.700	.900	10	

UNLESS OTHERWISE SPECIFIED DIMENSIONS ARE IN INCHES. TOLERANCES ON: DECIMALS ±.005 ANGLES ±	CONTRACT NO	AMP INCORPORATED Harrisburg, Pa. NAME AMPMODU MOD IV RECEPTACLE ASSY., SURFACE MOUNT .100 X .100 ☐ WITH BOTTOM ENTRY .260 HIGH		
	DR 12/18/86 D.L. HOFFMAN			
	CHK 3/19/92 R. BENDORF			
	APPD 3/19/92 R. BENDORF			
MATERIAL	APPD 3/19/92 R. BENDORF	SIZE	FSCM NO	DRAWING NO
FINISH	DSGN APPD	<b>D</b>	00779	534286
	OTHER APPD	SCALE	10:1	SHEET 1 of 1

单击下面可查看定价，库存，交付和生命周期等信息

[>>TE Connectivity\(泰科\)](#)