

THIS DRAWING IS UNPUBLISHED. RELEASED FOR PUBLICATION
 © COPYRIGHT 1963 BY TYCO ELECTRONICS CORPORATION. ALL RIGHTS RESERVED.

LOC	DIST	REVISIONS			
P	LTR	DESCRIPTION	DATE	DWN	APVD
AF	50	J1	REDRAWN PER ECR-07-029463	6DEC07	MF DD

- 1 CONTINUOUS STRIP ON REELS.
- 2 WIRE RANGE: 0.8-2.0mm² [#18-#14] AWG.

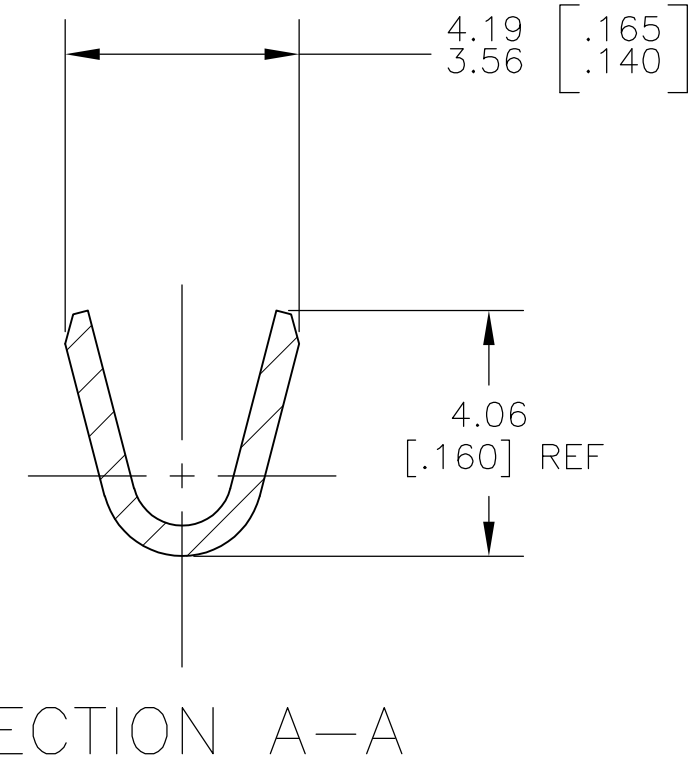
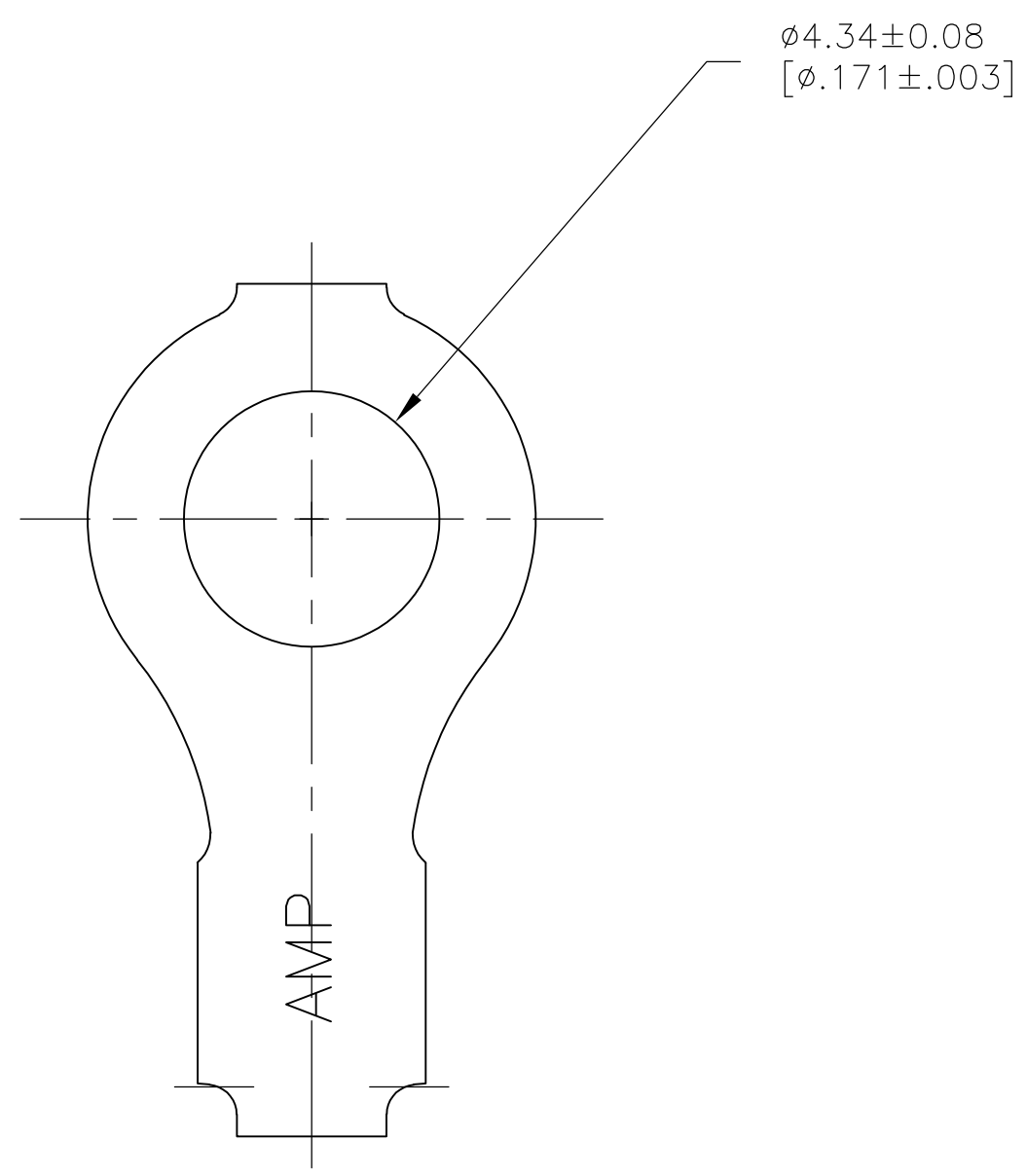
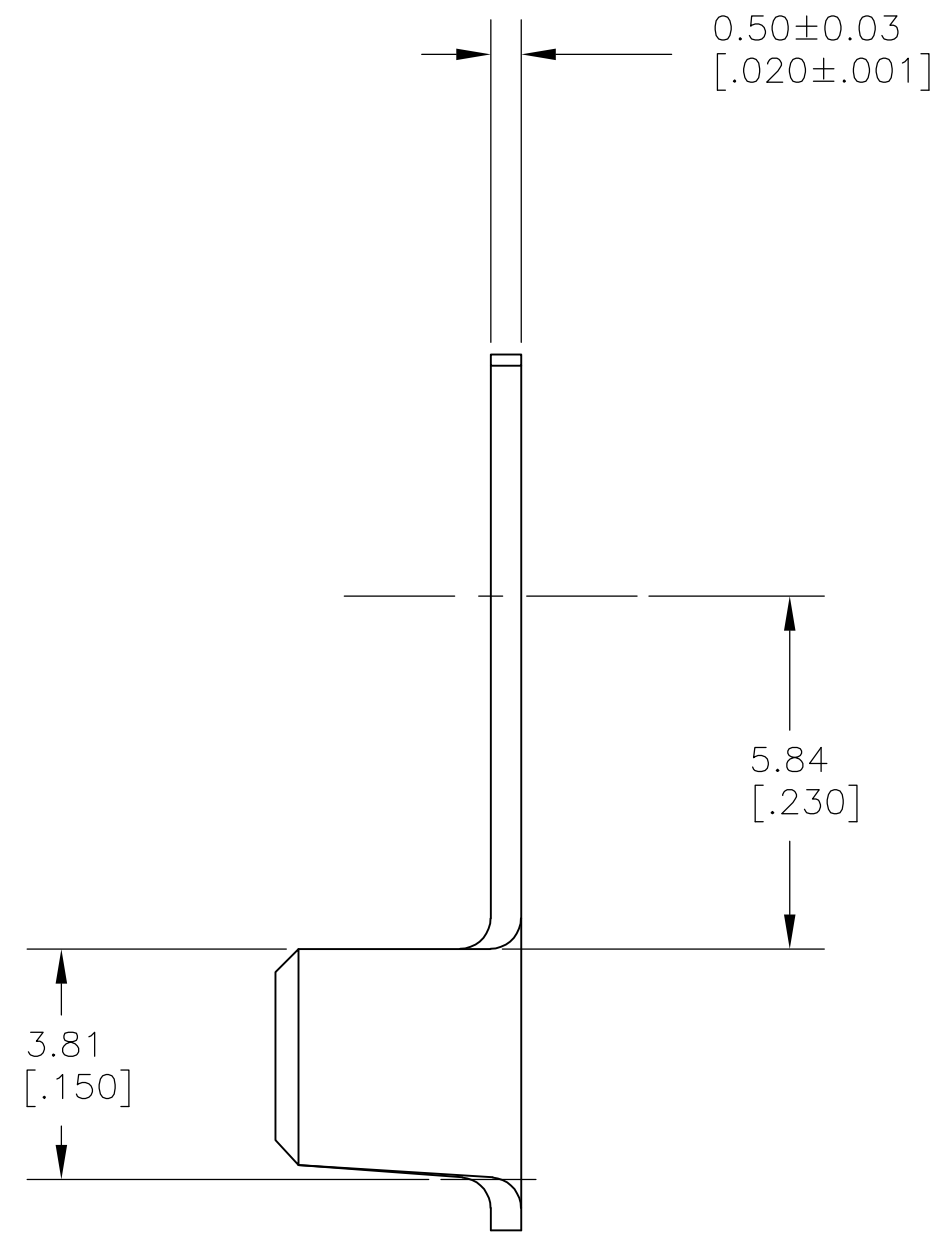
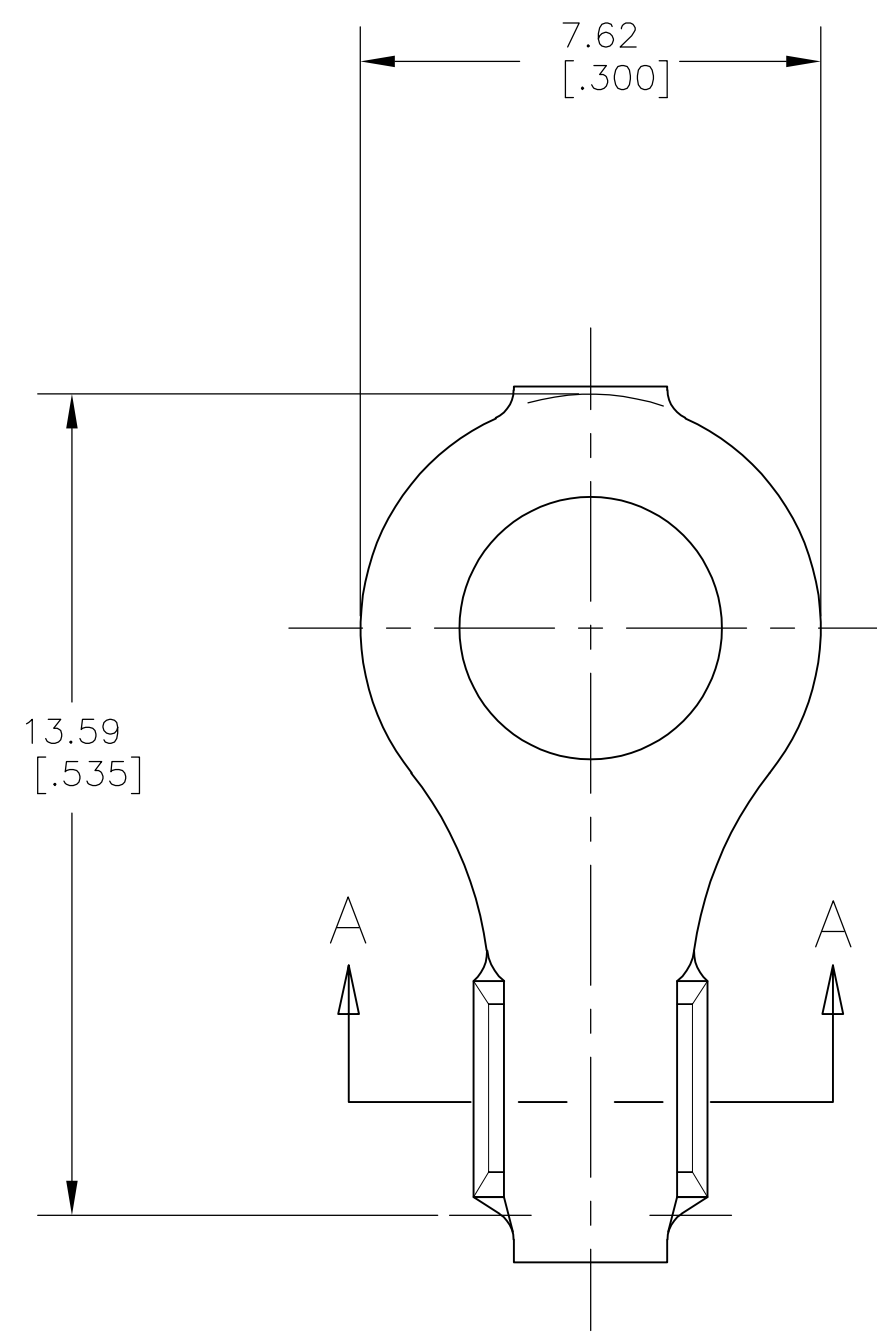

40594
PART NUMBER

THIS DRAWING IS A CONTROLLED DOCUMENT.		DWN 23OCT2007 MICHAEL S. FEHER	Tyco Electronics Corporation Harrisburg, PA 17105-3608	
DIMENSIONS: mm [INCHES]		CHK 23OCT2007 DONALD F. DECKER	NAME TERMINAL, RING NUMBER 8 STUD SIZE M4 METRIC	
TOLERANCES UNLESS OTHERWISE SPECIFIED: 0 PLC ± - 1 PLC ± - 2 PLC ± - 3 PLC ± 0.38 [.015] 4 PLC ± - ANGLES ± 1°		APVD 23OCT2007 DONALD F. DECKER	RESTRICTED TO	
MATERIAL 082 BRASS	FINISH TIN PLATE	PRODUCT SPEC -	SIZE A2	CAGE CODE 00779
CUSTOMER DRAWING		WEIGHT -	DRAWING NO C=40594	SCALE 8:1
		SHEET 1 of 1		REV J1

单击下面可查看定价，库存，交付和生命周期等信息

[>>TE Connectivity\(泰科\)](#)