

THIS DRAWING IS UNPUBLISHED. RELEASED FOR PUBLICATION 20
 © COPYRIGHT 20 BY TYCO ELECTRONICS CORPORATION. ALL RIGHTS RESERVED.

LOC		DIST		REVISIONS			
P	LTR	DESCRIPTION	DATE	DWN	APVD		
	A	PRELIMINARY	17JAN2007	SW	SH		
	B	REVISED ECO-07-001975	25JAN2007	SW	SH		
	C	REVISED PER ECO-07-005280	07MAR2007	SS	SH		
	D	REVISED ECO-07-022170	01OCT2007	SW	FD		

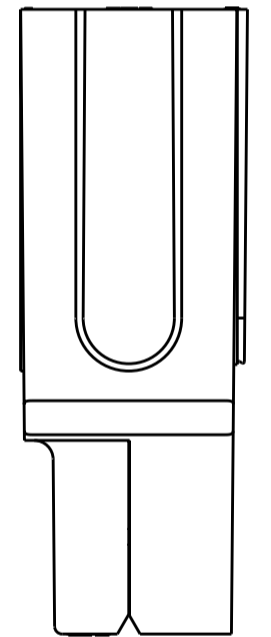
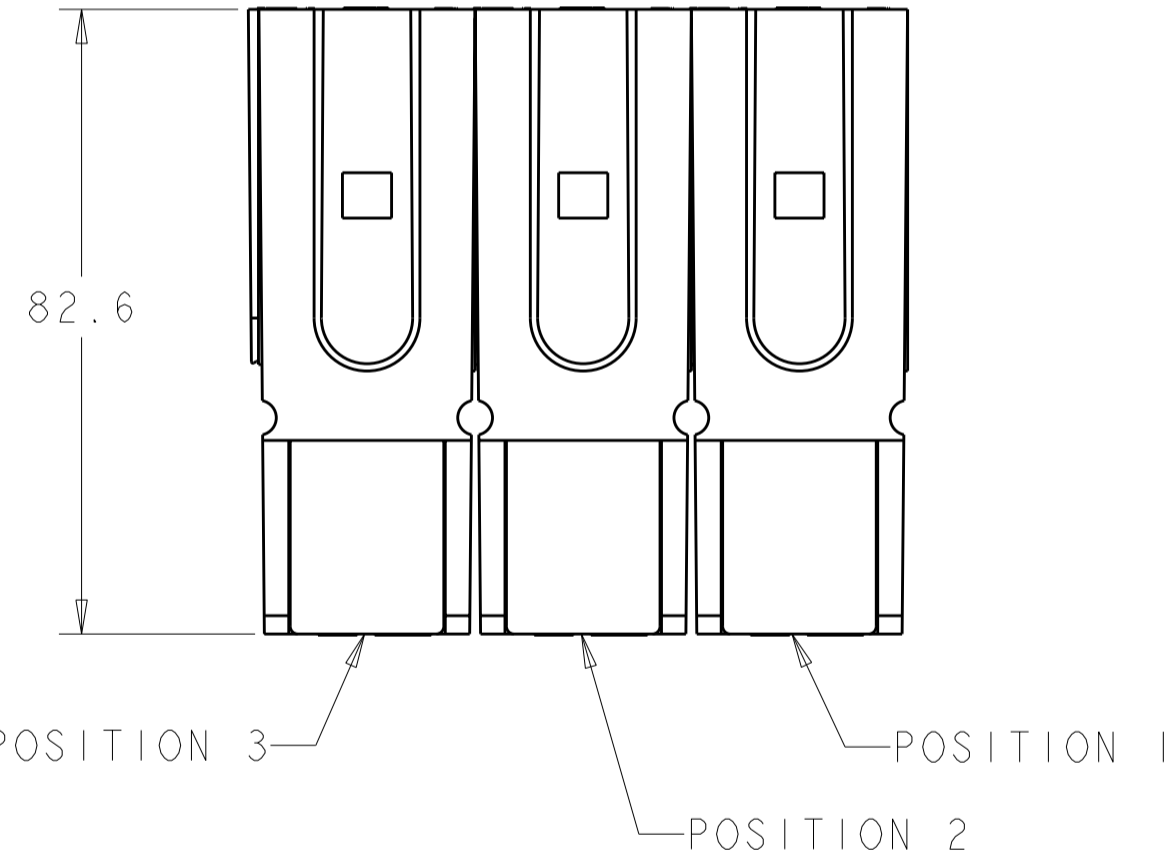
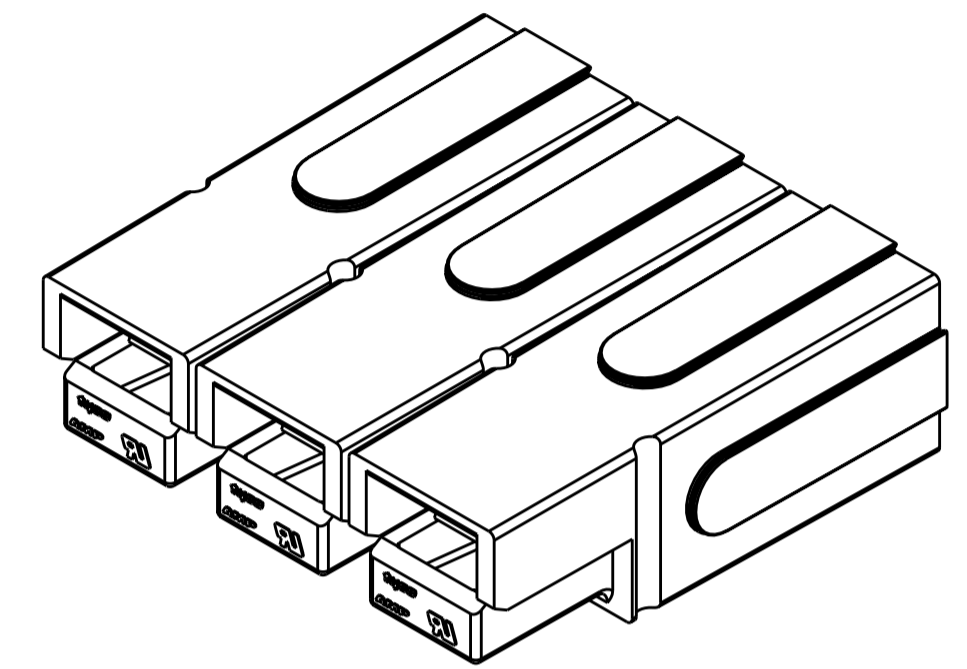
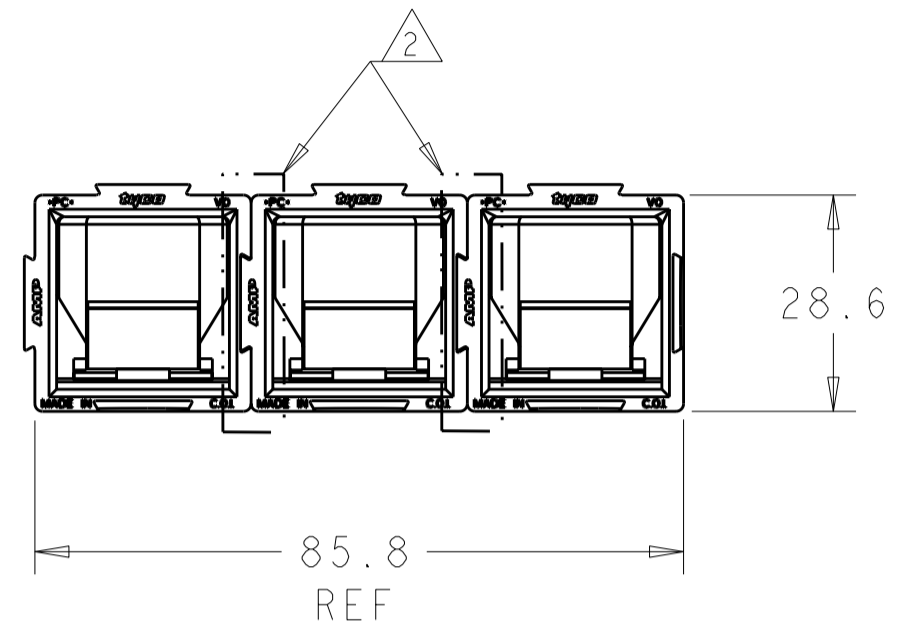

- ① MATERIAL AND FINISH:
HOUSING - POLYCARBONATE, COLOR: SEE TABLE
SPRING - STAINLESS STEEL
- ② ULTRASONICALLY WELDED IN AREA INDICATED.

2, 3	2	POSN 1	1	1986002-2
POSN 1	1	2, 3	2	1986002-1
POSN	QTY	POSN	QTY	PART NUMBER
RED		BLUE		
HOUSING SUBASSEMBLY				

THIS DRAWING IS A CONTROLLED DOCUMENT FOR TYCO ELECTRONICS CORPORATION IT IS SUBJECT TO CHANGE AND THE CONTROLLING ENGINEERING ORGANIZATION SHOULD BE CONTACTED FOR THE LATEST REVISION.		DWN S. WELDON 17JAN2007	Tyco Electronics Harrisburg, PA 17105-3608															
DIMENSIONS: mm		CHK S. HEADER 17JAN2007	NAME CONNECTOR ASSEMBLY, ULTRASONICALLY WELDED, AMP POWER SERIES 180															
TOLERANCES UNLESS OTHERWISE SPECIFIED:		APVD S. HEADER 17JAN2007																
<table border="0"> <tr><td>0 PLC</td><td>±0</td></tr> <tr><td>1 PLC</td><td>±0</td></tr> <tr><td>2 PLC</td><td>±0</td></tr> <tr><td>3 PLC</td><td>±0</td></tr> <tr><td>4 PLC</td><td>±0</td></tr> <tr><td>ANGLES</td><td>±</td></tr> <tr><td>FINISH</td><td></td></tr> </table>		0 PLC	±0	1 PLC	±0	2 PLC	±0	3 PLC	±0	4 PLC	±0	ANGLES	±	FINISH		PRODUCT SPEC -	SIZE A200779	DRAWING NO C-1986002
0 PLC	±0																	
1 PLC	±0																	
2 PLC	±0																	
3 PLC	±0																	
4 PLC	±0																	
ANGLES	±																	
FINISH																		
MATERIAL	-	APPLICATION SPEC -	RESTRICTED TO -															
CUSTOMER DRAWING		WEIGHT -	SCALE 1:1	SHEET 1 OF 1														

单击下面可查看定价，库存，交付和生命周期等信息

[>>TE Connectivity\(泰科\)](#)