

THIS DRAWING AND THE INFORMATION SET FORTH HERE-ON ARE THE PROPERTY OF TYCO ELECTRONICS CORPORATION, AND ARE TO BE HELD IN TRUST AND CONFIDENCE. PUBLICATION, DUPLICATION, DISCLOSURE, OR USE FOR ANY PURPOSE NOT EXPRESSLY AUTHORIZED IN WRITING BY TYCO ELECTRONICS CORPORATION IS PROHIBITED.

REVISIONS			
LTR	DESCRIPTION	DATE	APPROVED
A	REVISED PER ECN T-17686	92/Aug/12	J.B.
B	PER ECO-10-004081	FEB-25-2010	M.HIGGY

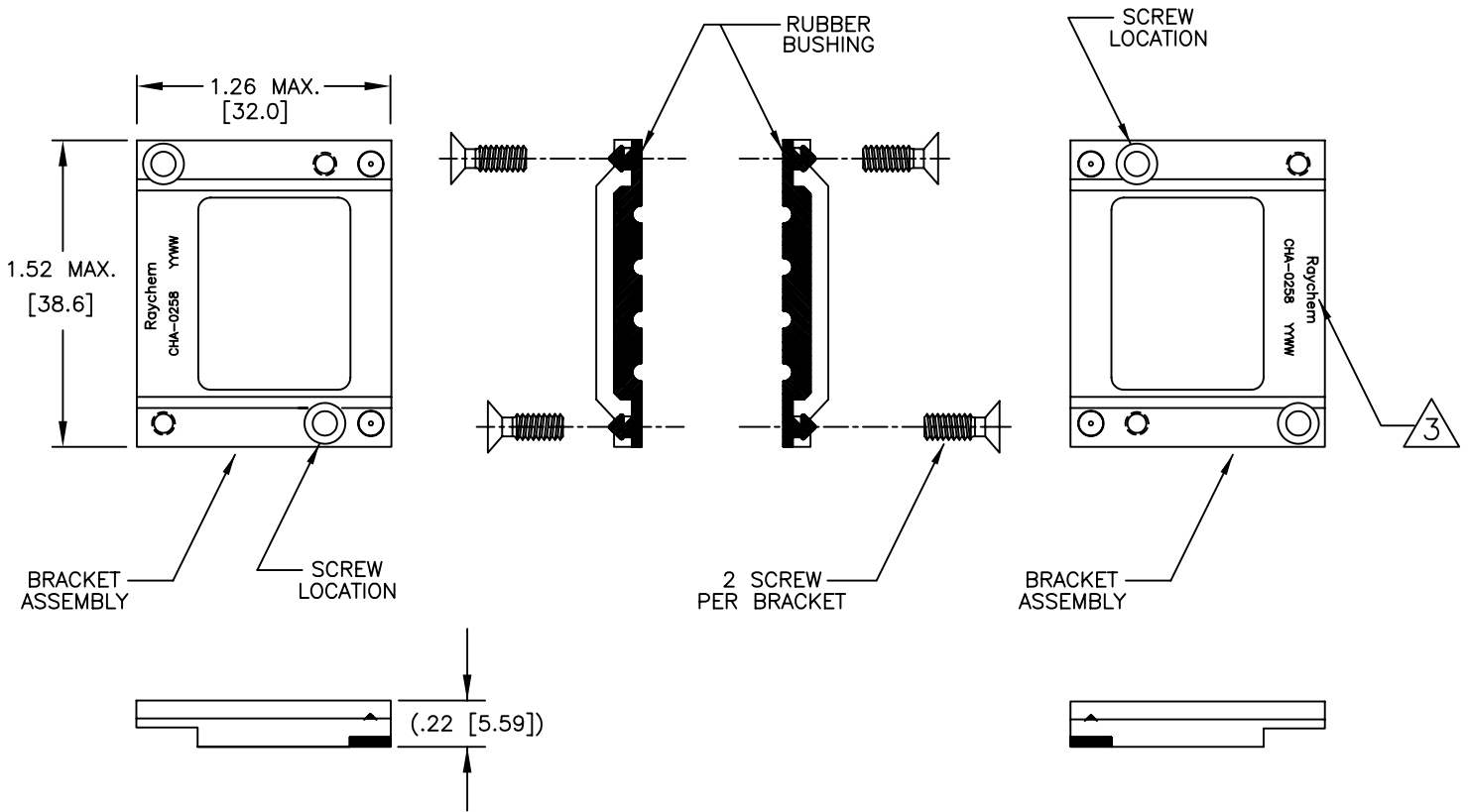

NOTES:

- MATERIAL:  
 BRACKET: ALUMINUM PER 6061-T6  
 RUBBER BUSHING: 70 SHORE FLUOROSILICONE WITH OIL RESISTANT, PER MIL-R-25988.  
 SCREW: CHROMIUM NICKEL 302 STAINLESS AISI 302 STAINLESS

- FINISH:  
 BRACKET: CADMIUM PLATE PER ES-22260  
 SCREW: CADMIUM PLATE PER ES-22266

- 3 RAYCHEM PART NUMBER AND DATE CODE MARKED APPROXIMATELY AS SHOWN.
- THIS ASSEMBLY CONTAINS (2) BRACKET ASSEMBLY AND FOUR (4) SCREWS.
- PACKAGE PER MIL-R-130.

If this document is printed it becomes uncontrolled. Check for the latest revision

©2010 Tyco Electronics Corporation. All rights reserved.

CUSTOMER DRAWING

UNLESS OTHERWISE SPECIFIED DIMENSIONS ARE IN INCHES. METRIC DIMENSIONS ARE IN BRACKETS.	DRAWN	ZS.O.	FEB/19/2010		Raychem Interconnect 300 Constitution Drive Menlo Park, CA 94025 U.S.A		
	CHECKED						
	APPROVED			TITLE	BRACKET, STRAIN RELIEF MTCR, ASSEMBLY		
	APPROVED	M.HIGGY	FEB/19/2010				
DECIMALS .XXX ± .XX ±	mm mm		CAD NAME	CHA-0258	SIZE	A	
ANGLES .X — ± —	THIRD ANGLE PROJECTION				CAGE CODE:	06090	
WEIGHT: 15.01g (0.033 Lbs) MAXIMUM.					DWG. NO.	CHA-0258	
						REV	B
						SHEET 1 OF 1	

单击下面可查看定价，库存，交付和生命周期等信息

[>>TE Connectivity\(泰科\)](#)