

THIS DRAWING IS UNPUBLISHED. RELEASED FOR PUBLICATION  
 © COPYRIGHT - By - ALL RIGHTS RESERVED.

REVISIONS				
P	LTR	DESCRIPTION	DATE	APVD
B		UPDATE PER ECO-16-002588	24 FEB 16	CAS CAS

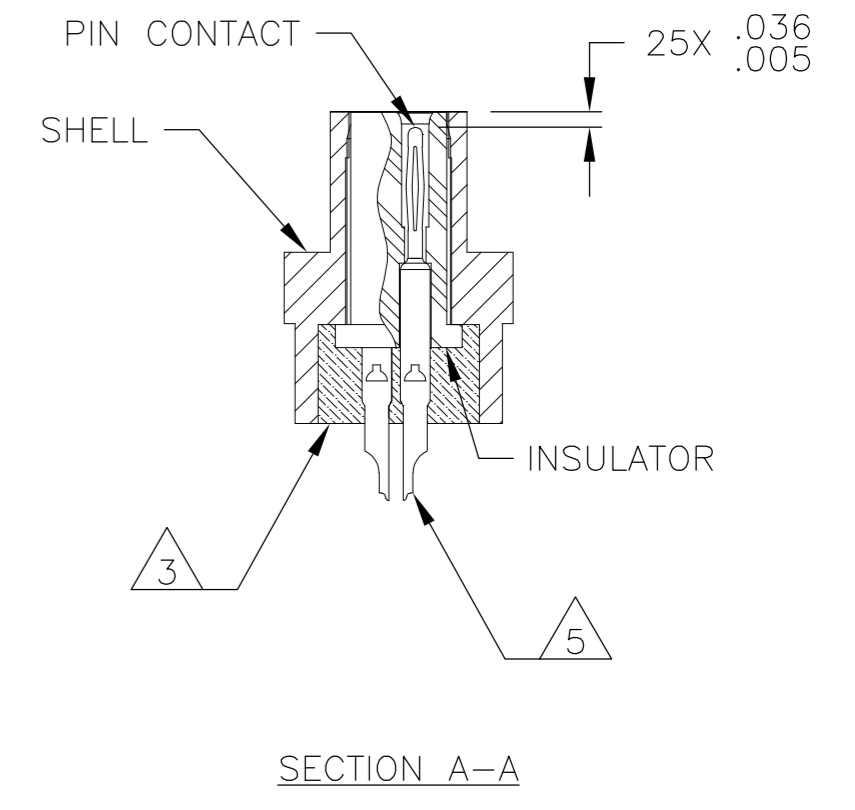
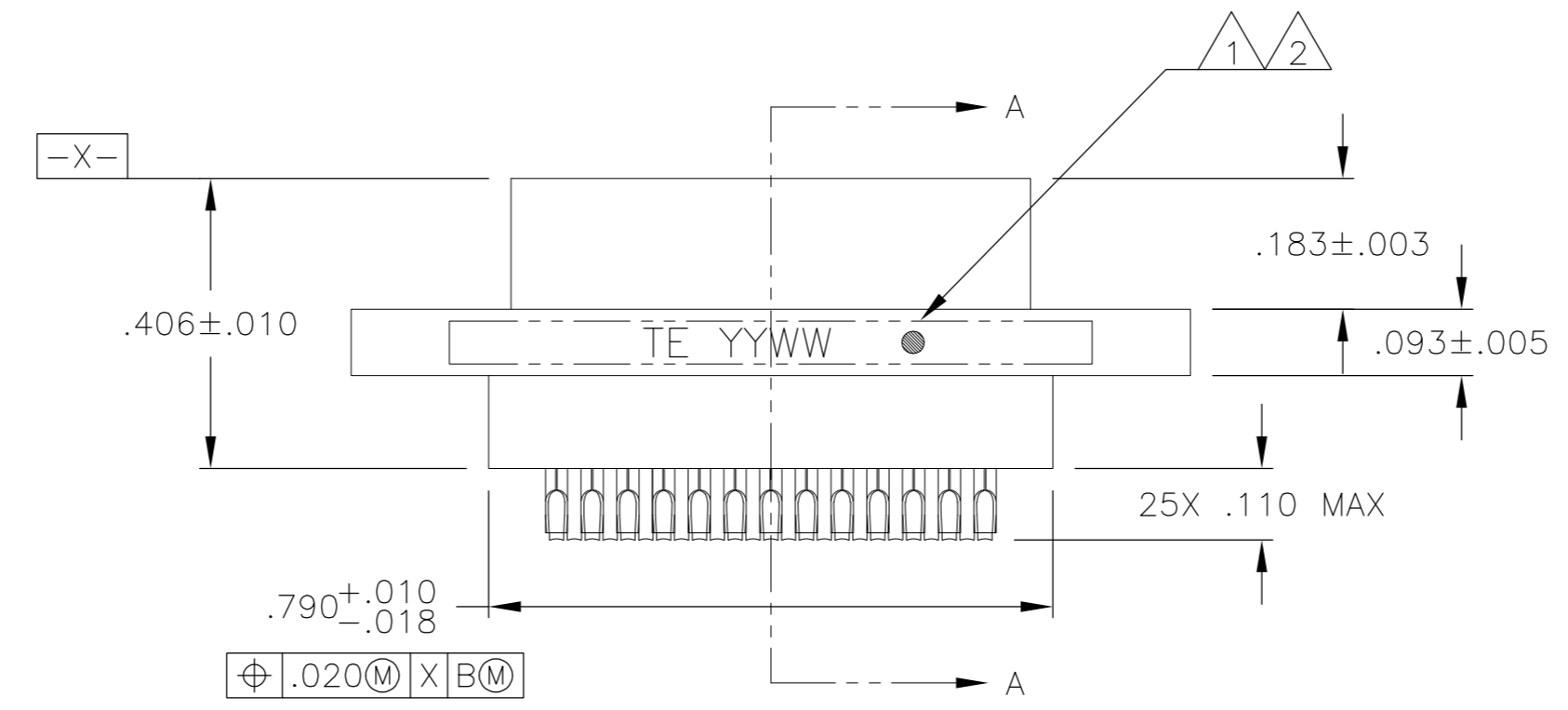
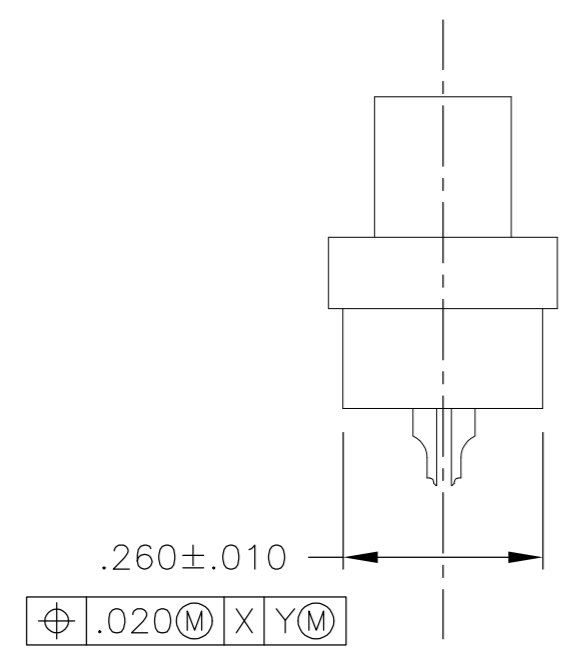
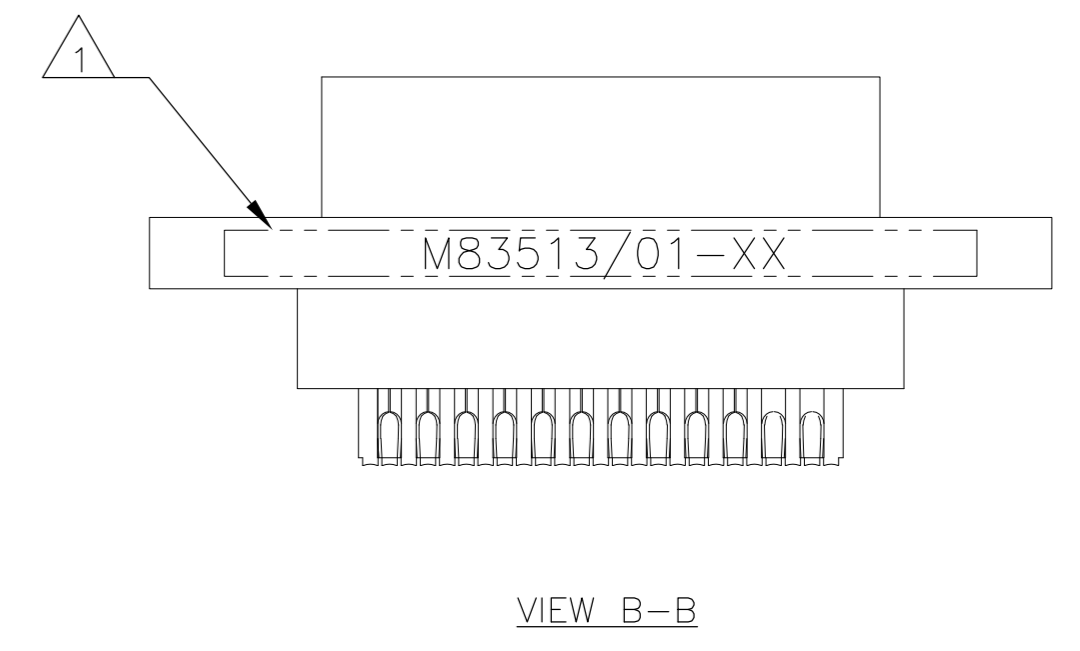
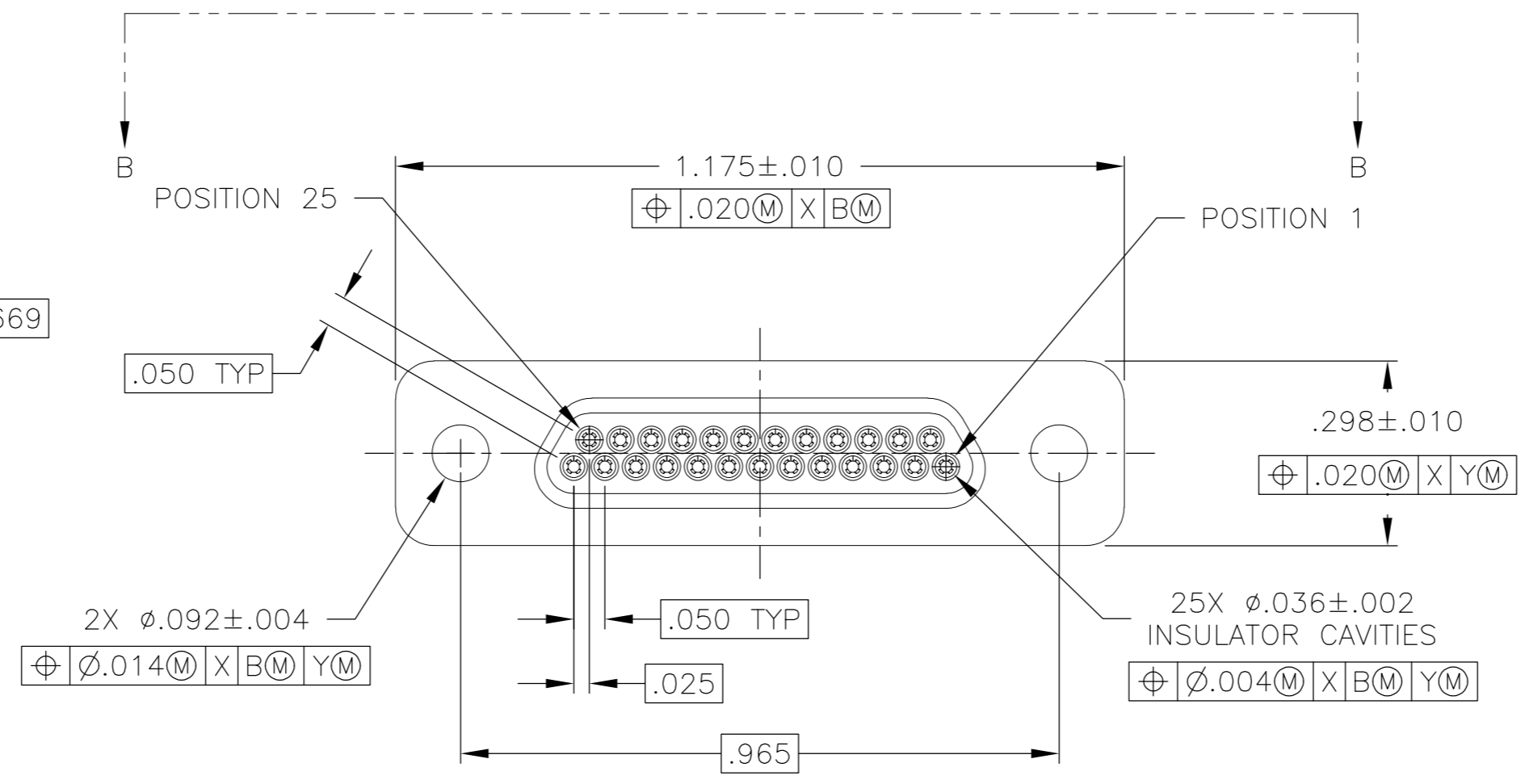
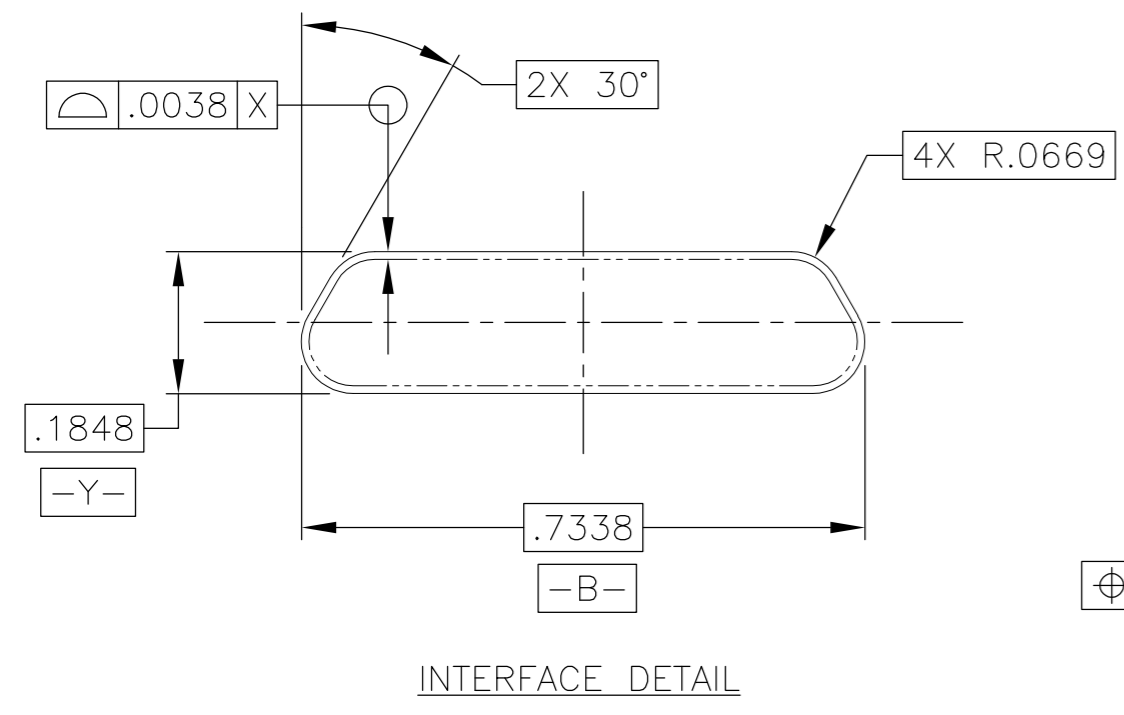

- 1 CONNECTOR SHALL BE MARKED IN ACCORDANCE WITH METHOD I OF MIL-STD-1285. MARKING SHALL CONTAIN THE MILITARY PIN, CAGE CODE (OR TE), AND DATE CODE. EXAMPLE: M83513/01-XX TE YYWW (WHERE XX IS PART OF THE PIN SHOWN IN THE "MIL-DTL-83513" COLUMN OF THE PART NUMBER TABLE, AND YYWW IS THE DATE CODE). FOR THE SIZE 25 PLUG, THE MARKING MUST BE PRINTED ON BOTH SIDES OF THE FLANGE. TEXT HEIGHT SHALL BE .035 INCH MINIMUM.
- 2 POSITION 1 SHALL BE INDICATED BY AN IDENTIFIABLE MARK, LOCATED APPROXIMATELY AS SHOWN ON THE POSITION 1 SIDE OF THE CONNECTOR FLANGE. THIS MARK SHALL BE INCLUDED AS PART OF THE PART MARKING INFORMATION.
- 3 EPOXY ENCAPSULATION. EPOXY MAY WICK .050 INCH MAX FOR SOLDER CUPS.
- 4 ALL DIMENSIONS AND REQUIREMENTS ARE PER MIL-DTL-83513/1
- 5 CHAMFER ON SOLDER POTS ARE PARALLEL WITH THE SIDE OF CONNECTOR WITHIN  $10^\circ$

THIS DRAWING IS A CONTROLLED DOCUMENT.		DWN B. ROMANCHUK 03 SEP 08		
DIMENSIONS: INCHES		CHK M. STORRY 03 SEP 08		
TOLERANCES UNLESS OTHERWISE SPECIFIED:		NAME PLUG ASSEMBLY, MICRO-D PER MIL-DTL-83513/01, MCKS SERIES, 25 POSITION		
		PRODUCT SPEC		
MATERIAL SEE NOTES		APPLICATION SPEC		
FINISH		WEIGHT		
		SCALE 4:1 SHEET 1 of 2 REV B		
		CUSTOMER DRAWING		



单击下面可查看定价，库存，交付和生命周期等信息

[>>TE Connectivity\(泰科\)](#)