

THIS DRAWING IS UNPUBLISHED. RELEASED FOR PUBLICATION 20
 © COPYRIGHT 20 BY - ALL RIGHTS RESERVED.

| LOC | DIST | REVISIONS | | | | | |
|-----|------|-----------|-----|-----------------|-----------|-----|------|
| GP | 00 | P | LTR | DESCRIPTION | DATE | DWN | APVD |
| | | 6 | | UPDATE | 25JUN2013 | JY | AC |
| | | A | | INITIAL RELEASE | 16DEC2014 | JY | MC |

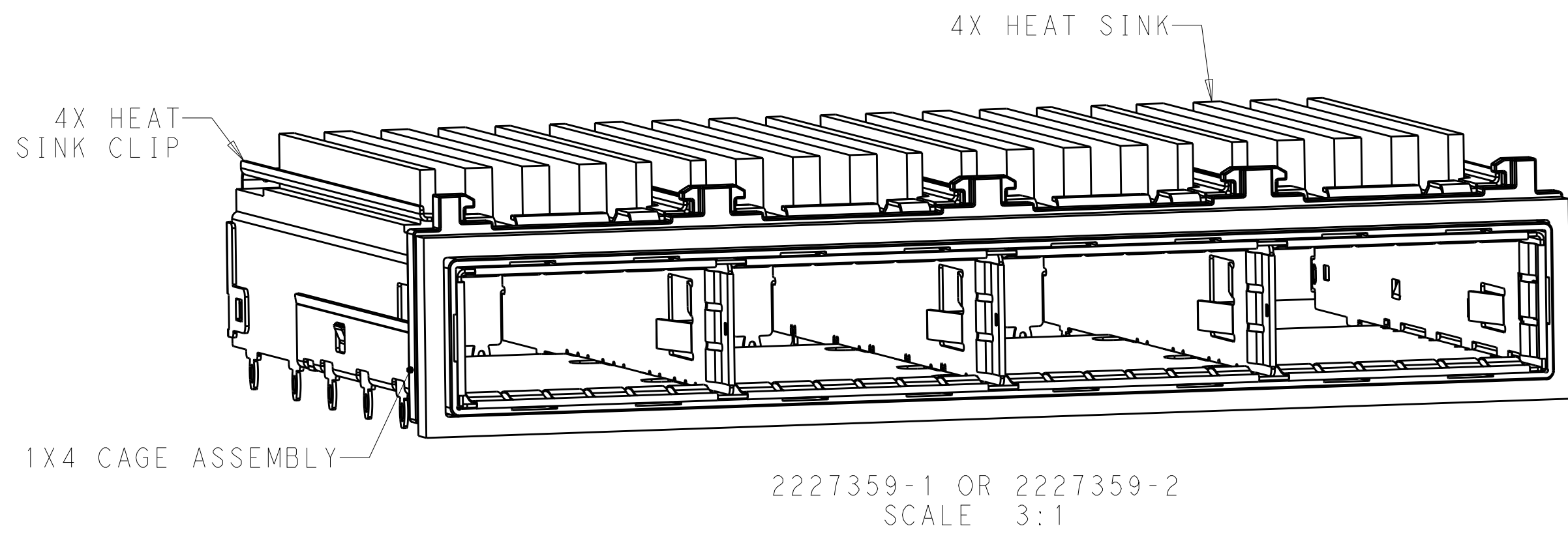

- COMPONENTS
 CAGE ASSEMBLY: NICKEL-SILVER ALLOY
 HEAT SINK: ALUMINUM/NICKEL PLATE
 HEAT SINK CLIP: STAINLESS STEEL
 EMI SPRING: COPPER ALLOY/TIN PLATE
 FRONT FLANGE: STAINLESS STEEL
 EMI GASKET: SILVER PLATED URETHANE

- REFERENCE APPLICATION SPECIFICATION 114-32046 FOR RECOMMENDED DRILL HOLE DIAMETER AND PLATING THICKNESS
- DATUM AND BASIC DIMENSION ESTABLISHED BY CUSTOMER WITH MODULE INSERTED IN CAGE
- HEAT SINKS, HEAT SINK CLIPS ARE SHIPPED ASSEMBLED ON CAGE

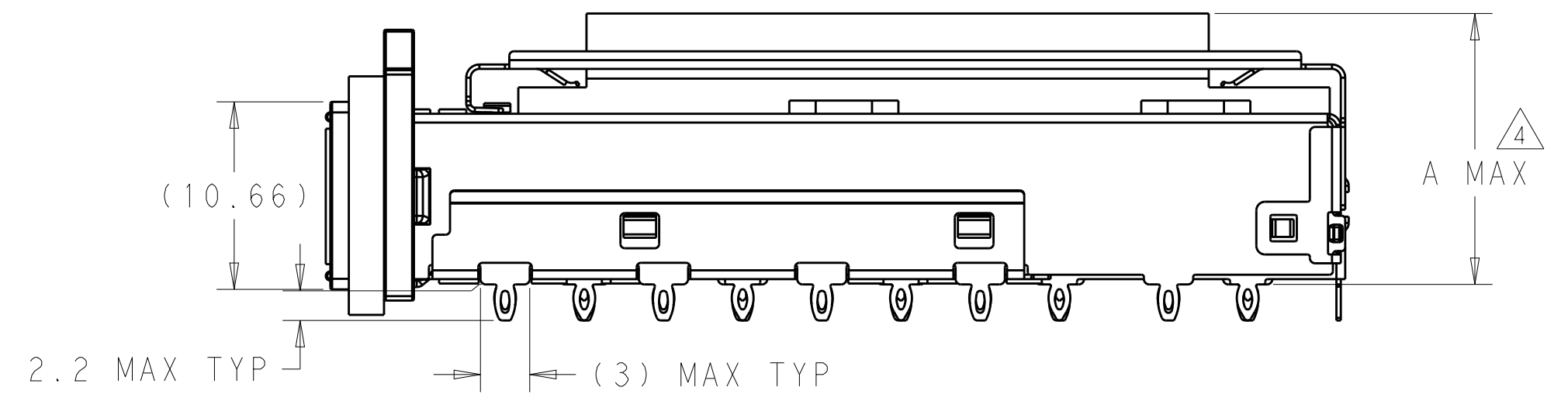
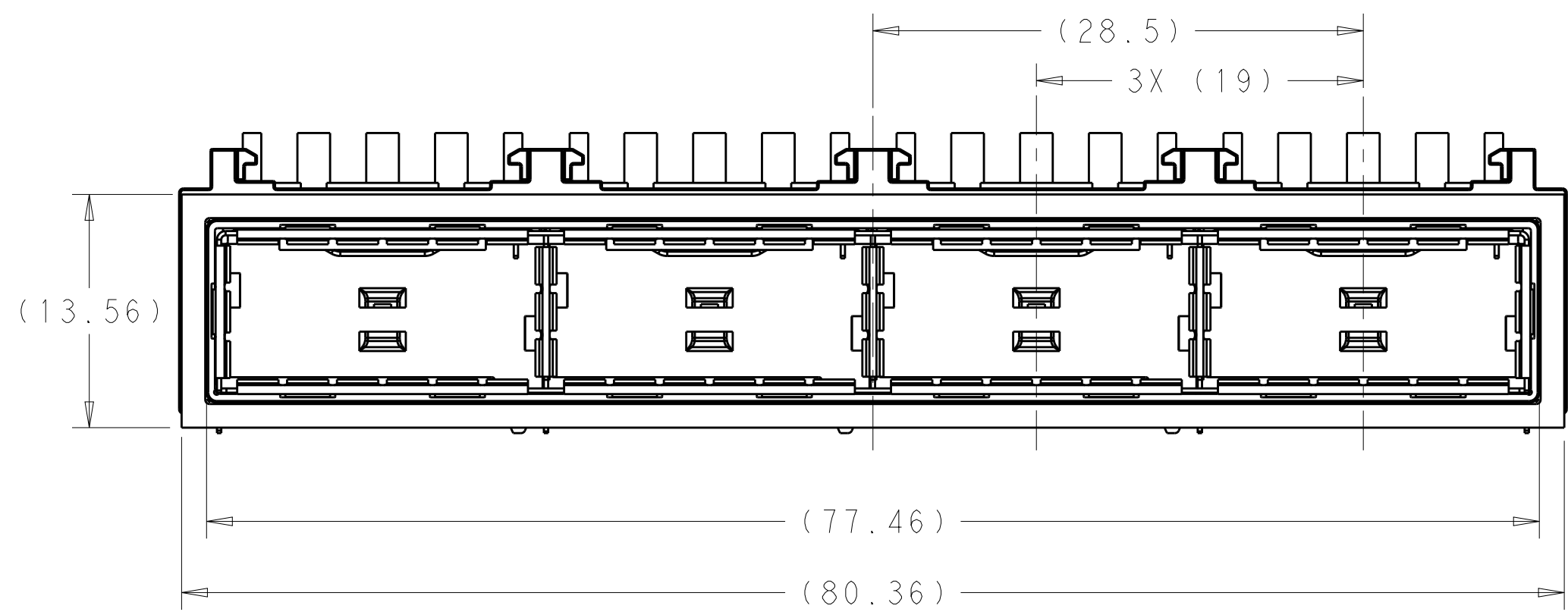

| | |
|-------|-------------|
| 18.61 | 2227359-2 |
| 16.66 | 2227359-1 |
| DIM A | PART NUMBER |

| | | | | |
|--|-----------|------------------------------------|---|--------------------|
| THIS DRAWING IS A CONTROLLED DOCUMENT. | | DWN M.E. COWHER 10OCT2012 | STE TE Connectivity | |
| DIMENSIONS: mm | | CHK M.D. MORRISON 10OCT2012 | | |
| TOLERANCES UNLESS OTHERWISE SPECIFIED: | | APVD M.D. MORRISON 10OCT2012 | NAME RECEPTACLE ASSEMBLY, THRU BEZEL, 1X4, QSF28 | |
| 0 PLC ± | 1 PLC ± | PRODUCT SPEC 108-19428 | SIZE A2 | CAGE CODE 00779 |
| 2 PLC ± | 3 PLC ± | APPLICATION SPEC | DRAWING NO C-2227359 | RESTRICTED TO |
| 4 PLC ± | ANGLES ± | WEIGHT | SCALE 3:1 | SHEET 1 OF 5 |
| FINISH | SEE NOTES | Customer Drawing | REV A | |

THIS DRAWING IS UNPUBLISHED. RELEASED FOR PUBLICATION 20
 © COPYRIGHT 20 BY - ALL RIGHTS RESERVED.

| LOC | DIST | REVISIONS | | | | | |
|-----|------|-----------|-----|-------------|------|-----|------|
| GP | 00 | P | LTR | DESCRIPTION | DATE | DWN | APVD |
| | | - | | SEE SHEET 1 | | | |

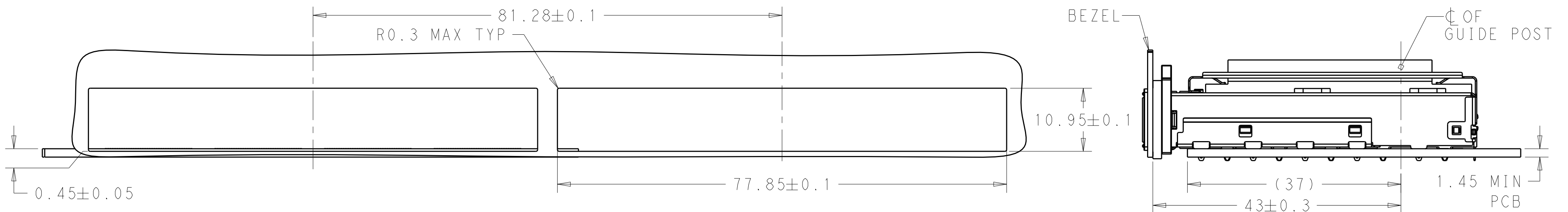

SHOWN IN SINGLE SIDE
 BEZEL/PCB CONFIGURATION
 SCALE 2:1

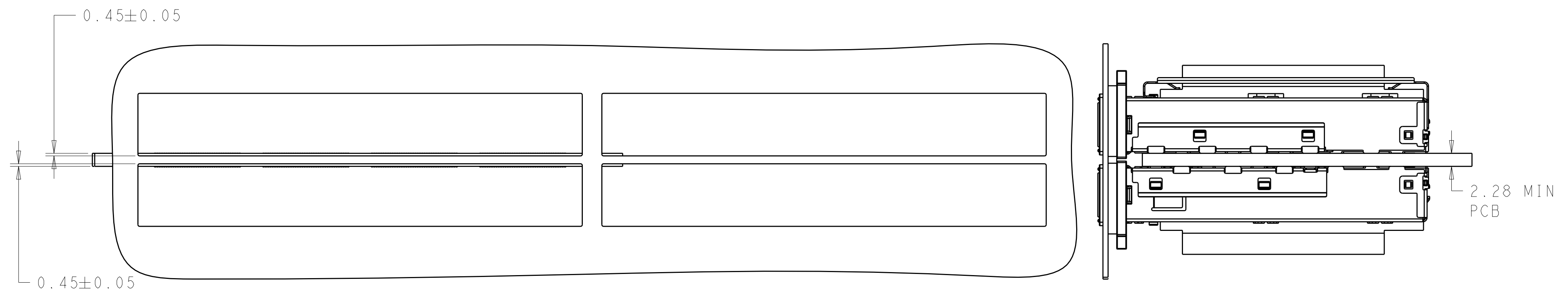

SHOWN IN BELLY TO BELLY
 BEZEL/PCB CONFIGURATION
 SAME AS ABOVE, EXCEPT AS SHOWN
 SCALE 2:1

| | | | | |
|--|-----------|-------------------------------------|---|-------------------------|
| THIS DRAWING IS A CONTROLLED DOCUMENT. | | DWN M. E. COWHER 10OCT2012 | TE Connectivity | |
| DIMENSIONS: mm | | CHK M. D. MORRISON 10OCT2012 | | |
| TOLERANCES UNLESS OTHERWISE SPECIFIED: | | APVD M. D. MORRISON 10OCT2012 | NAME RECEPTACLE ASSEMBLY, THRU BEZEL, 1X4, QSFP28 | |
| 0 PLC ± | 1 PLC ± | PRODUCT SPEC 108-19428 | SIZE A200779 | DRAWING NO C-2227359 |
| 2 PLC ± | 3 PLC ± | APPLICATION SPEC | RESTRICTED TO | |
| 4 PLC ± | ANGLES ± | WEIGHT | SCALE 3:1 SHEET 2 OF 5 REV A | |
| MATERIAL | FINISH | Customer Drawing | | |
| SEE NOTES | SEE NOTES | | | |

THIS DRAWING IS UNPUBLISHED. RELEASED FOR PUBLICATION 20
COPYRIGHT 20 BY - ALL RIGHTS RESERVED.

| LOC | DIST | REVISIONS | | | | | |
|-----|------|-----------|-----|-------------|------|-----|------|
| GP | 00 | P | LTR | DESCRIPTION | DATE | DWN | APVD |
| | | - | | SEE SHEET 1 | | | |

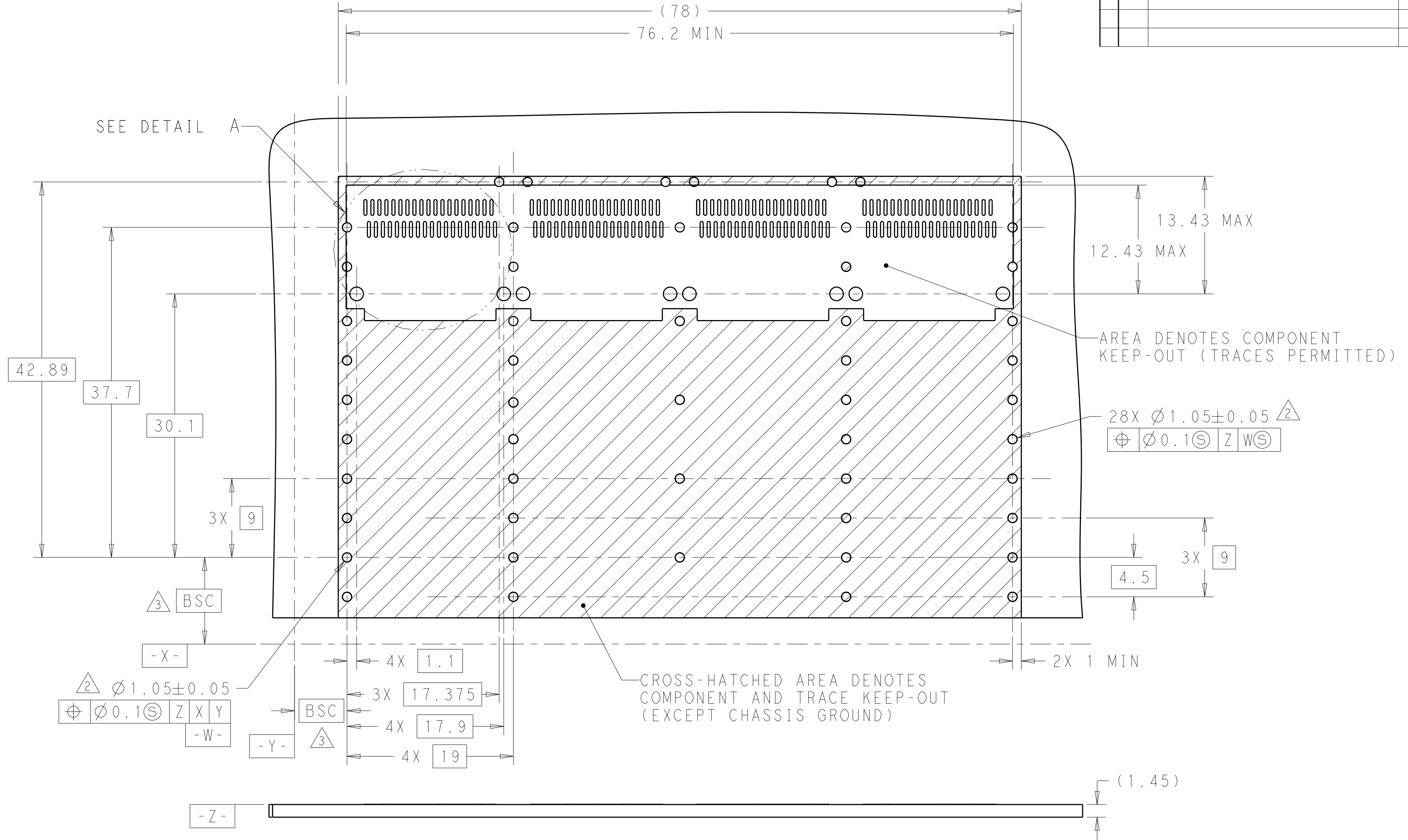

RECOMMENDED PCB LAYOUT
SINGLE SIDE MOUNTED CONFIGURATION
SCALE 3:1

| | | | | |
|---|--|-------------------------------------|--|--------------------|
| THIS DRAWING IS A CONTROLLED DOCUMENT. | | DWN M. E. COWHER 10OCT2012 |  TE Connectivity | |
| DIMENSIONS: mm | | CHK M. D. MORRISON 10OCT2012 | | |
| TOLERANCES UNLESS OTHERWISE SPECIFIED: | | APVD M. D. MORRISON 10OCT2012 | NAME RECEPTACLE ASSEMBLY, THRU BEZEL, 1X4, QSF28 | |
| 0 PLC ± 1 PLC ± 2 PLC ± 3 PLC ± 4 PLC ± ANGLES ± FINISH ± | | PRODUCT SPEC 108-19428 | SIZE A2 | CAGE CODE 00779 |
| MATERIAL SEE NOTES | | APPLICATION SPEC | DRAWING NO C-2227359 | RESTRICTED TO - |
| WEIGHT - | | Customer Drawing | SCALE 3:1 | SHEET 3 OF 5 |
| | | | REV A | |

THIS DRAWING IS UNPUBLISHED. RELEASED FOR PUBLICATION 20
 © COPYRIGHT 20 BY - ALL RIGHTS RESERVED.

| LOC | DIST | REVISIONS | | | | | |
|-----|------|-----------|-----|-------------|------|-----|------|
| GP | 00 | P | LTR | DESCRIPTION | DATE | DWN | APVD |
| | | - | | SEE SHEET 1 | | | |

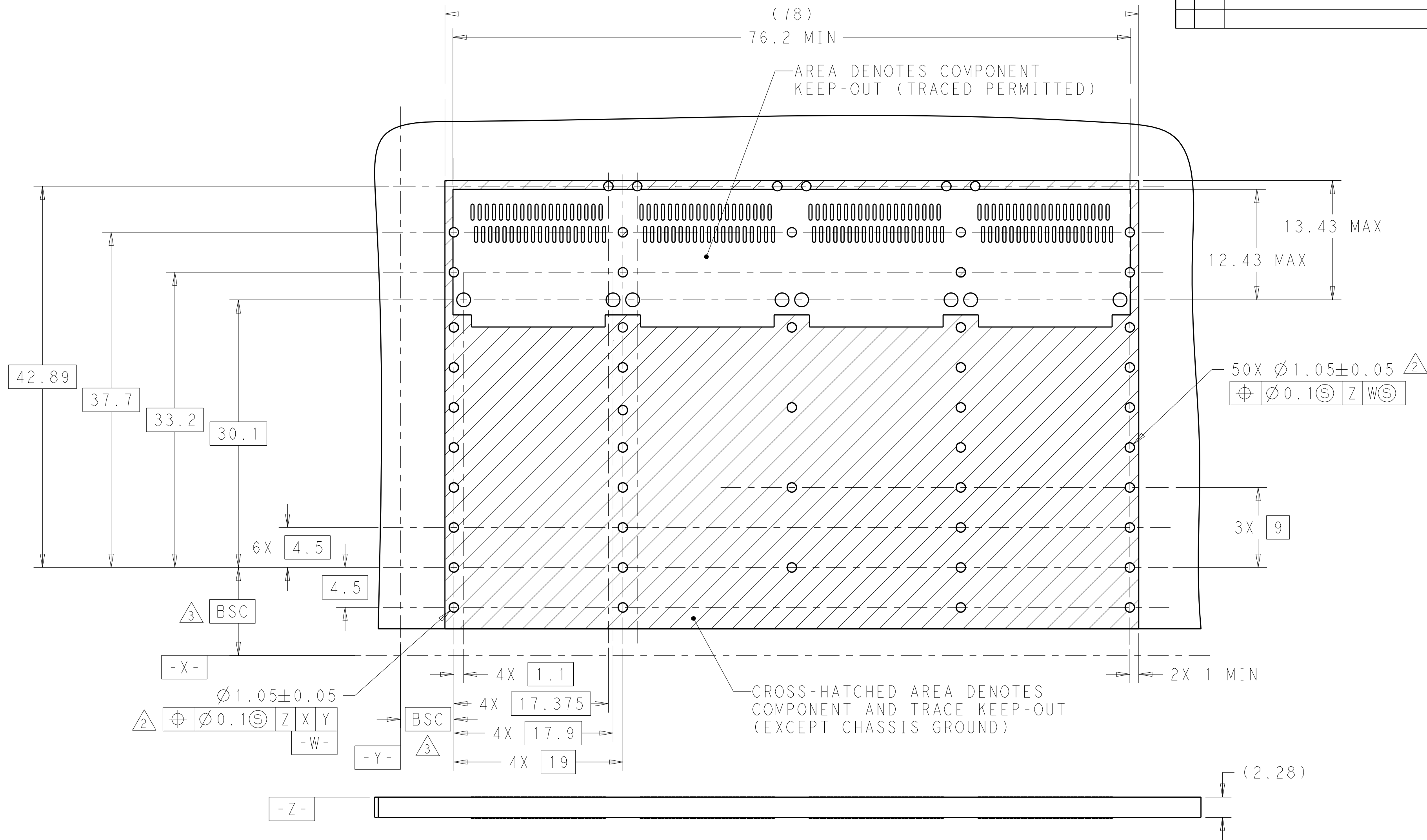

RECOMMENDED PCB LAYOUT
 BELLY TO BELLY MOUNTED CONFIGURATION
 SCALE 3:1

| | | | |
|---|--|---|---------------------|
| THIS DRAWING IS A CONTROLLED DOCUMENT. | | DWN M. E. COWHER 10OCT2012 | TE Connectivity |
| DIMENSIONS: mm | | CHK M. D. MORRISON 10OCT2012 | |
| TOLERANCES UNLESS OTHERWISE SPECIFIED: | | APVD M. D. MORRISON 10OCT2012 | |
| 0 PLC ± 1 PLC ± 2 PLC ± 3 PLC ± 4 PLC ± ANGLES ± FINISH ± | | PRODUCT SPEC 108-19428 APPLICATION SPEC - WEIGHT - | |
| MATERIAL | | NAME RECEPTACLE ASSEMBLY, THRU BEZEL, 1X4, QSF28 | |
| SEE NOTES | | SIZE A200779 | |
| SEE NOTES | | DRAWING NO C-2227359 | |
| Customer Drawing | | RESTRICTED TO - | |
| SCALE 3:1 | | SHEET 4 OF 5 | |
| | | REV A | |

THIS DRAWING IS UNPUBLISHED. RELEASED FOR PUBLICATION 20
 © COPYRIGHT 20 BY - ALL RIGHTS RESERVED.

| LOC | DIST | REVISIONS | | | | | |
|-----|------|-----------|-----|-------------|------|-----|------|
| GP | 00 | P | LTR | DESCRIPTION | DATE | DWN | APVD |
| | | - | | SEE SHEET 1 | - | - | - |
| | | | | | | | |
| | | | | | | | |

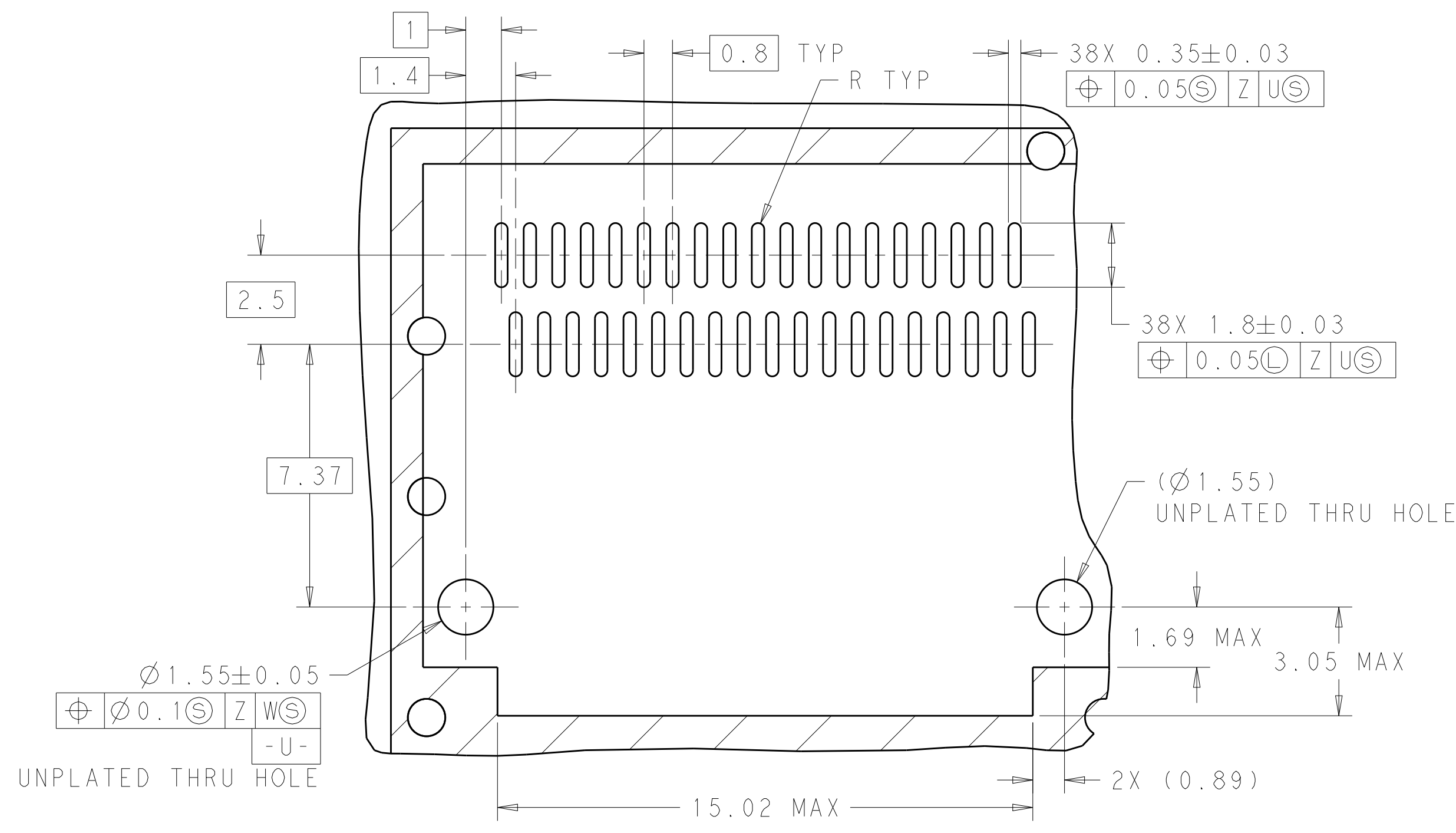

DETAIL A
 RECOMMENDED CONNECTOR LAYOUT
 (APPLIES TO ALL PCB LAYOUTS)
 4X INDIVIDUALLY
 SCALE 8:1

| | | | | |
|---|--|-------------------------------------|---|-------------------------|
| THIS DRAWING IS A CONTROLLED DOCUMENT. | | DWN M. E. COWHER 10OCT2012 |  TE Connectivity | |
| DIMENSIONS: mm | | CHK M. D. MORRISON 10OCT2012 | | |
| TOLERANCES UNLESS OTHERWISE SPECIFIED: | | APVD M. D. MORRISON 10OCT2012 | NAME RECEPTACLE ASSEMBLY, THRU BEZEL, 1X4, QSFP28 | |
| 0 PLC ± 1 PLC ± 2 PLC ± 3 PLC ± 4 PLC ± ANGLES ± FINISH ± | | PRODUCT SPEC 108-19428 | SIZE A200779 | DRAWING NO C-2227359 |
| MATERIAL SEE NOTES | | WEIGHT - | RESTRICTED TO - | SCALE 3:1 |
| SEE NOTES | | Customer Drawing | SHEET 5 | OF 5 |
| | | | REV A | |

单击下面可查看定价，库存，交付和生命周期等信息

[>>TE Connectivity\(泰科\)](#)