

THIS DRAWING IS UNPUBLISHED. / DIFFUSION RESTREINTE  
 RELEASED FOR PUBLICATION / LIBRE A LA DIFFUSION  
 2013  
 ALL RIGHTS RESERVED. / TOUS DROITS RESERVES

REVISIONS					
P	LTR	DESCRIPTION MODIFICATIONS	DATE	DWN DESS.	APVD APP.
C		UPDATE 3D VIEW OF COMPONENT "B"	10AUG2011	PF s	JD r
D		ADDED POSSIBLE FORMS IN SLIDER	08NOV2017	ASB	SA
E		CORRECTION IN ZONE A4 AND B2	20FEB2018	ASB	SA
F		ADDED NOTE IN ZONE B1	23OCT2018	ASB	GKT

FORMES POSSIBLES DANS ETRIER  
 POSSIBLE FORMS IN SLIDER



DETAIL A  
 SCALE 3:1

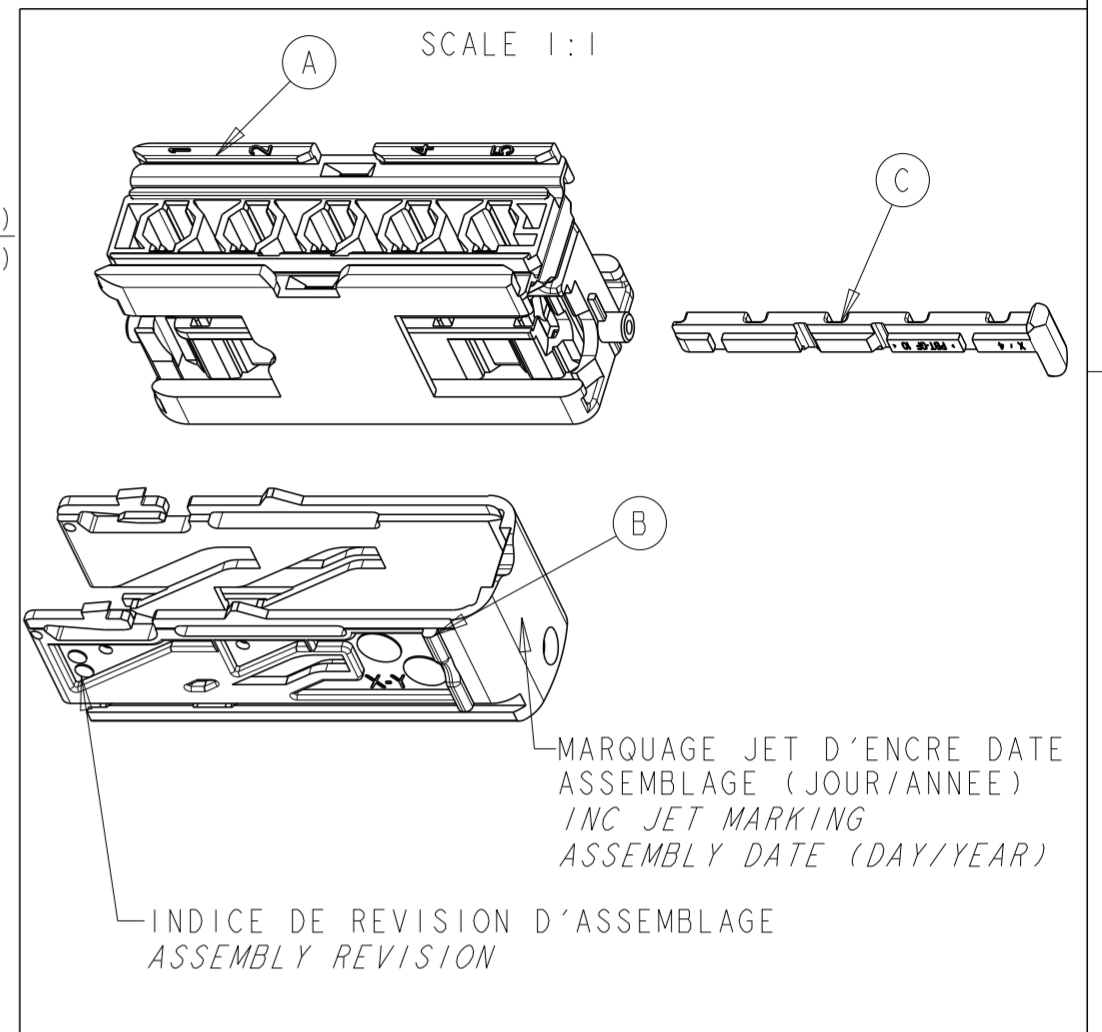
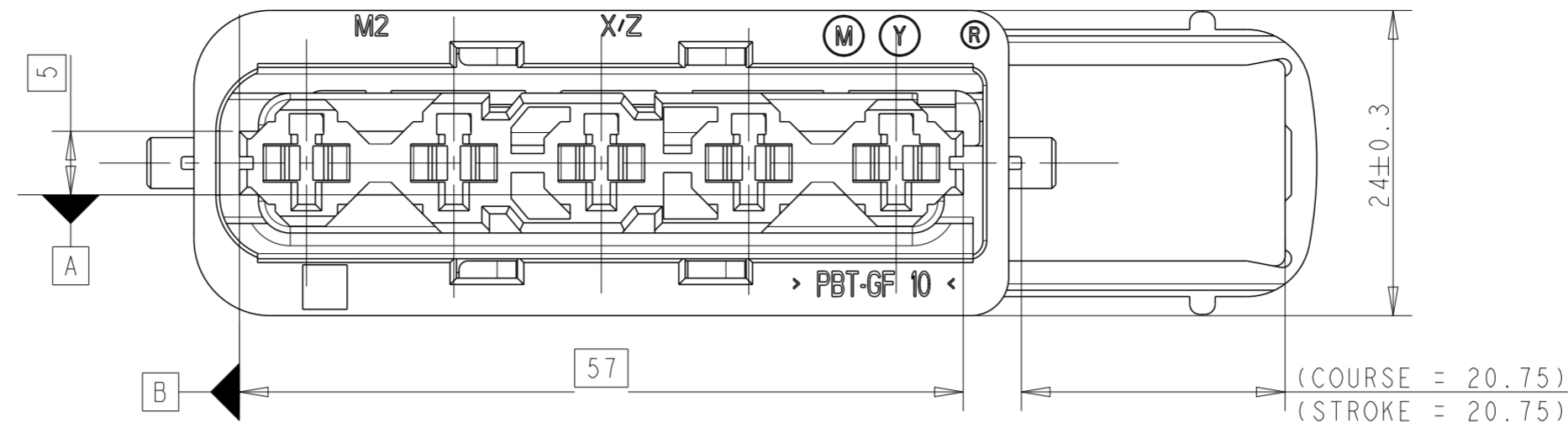

SECTION B-B

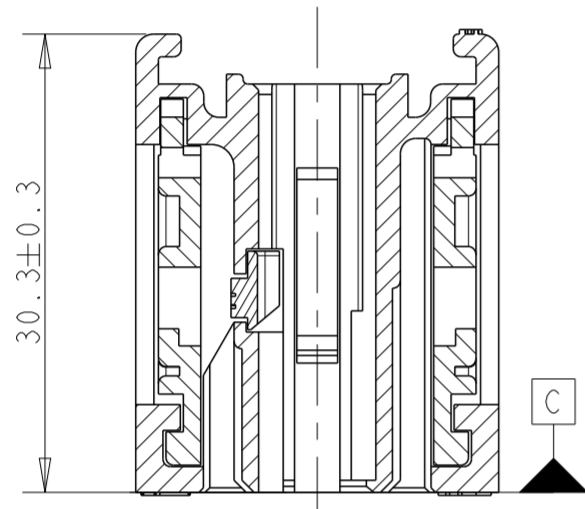

SECTION 1-1

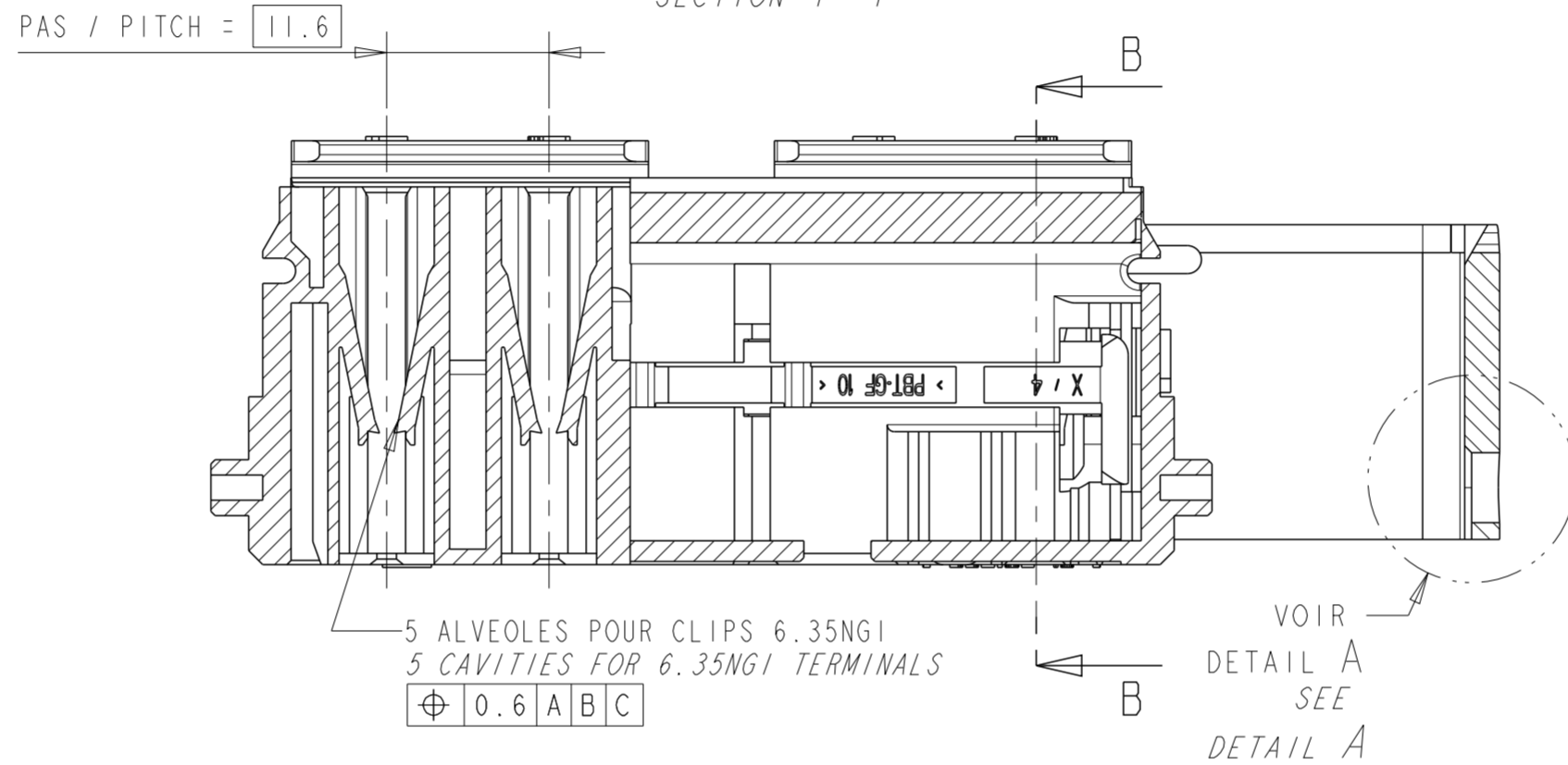

OPENED VERSIONS: 92±0.5

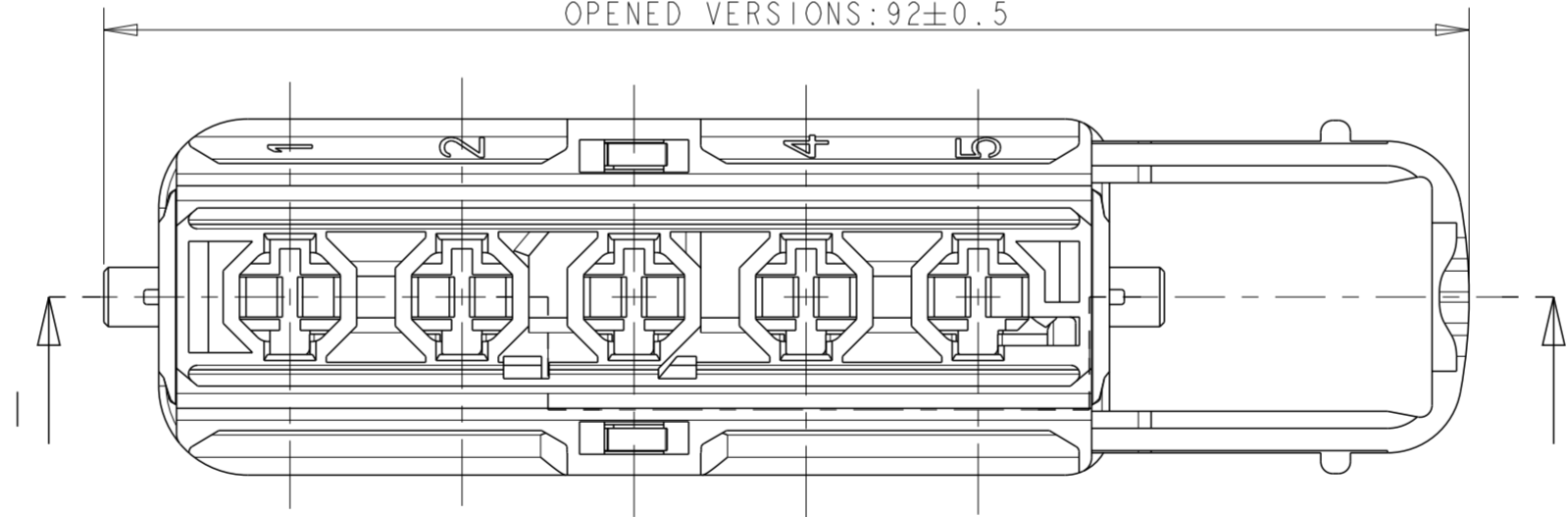

NOTA / NOTE :  
 - CONDITIONNEMENT, VOIR 107-15595  
 - PACKAGING, SEE 107-15595

(F) - ETRIER EN POSITION OUVERTE (POSITION PREFERENTIELLE DE LIVRAISON). SI LE ETRIER N'EST PAS DANS CETTE POSITION SUIVRE LES INSTRUCTIONS DE LA NOTICE TECHNIQUE 411-15658  
 - SLIDE IN OPEN POSITION (PREFERRED DELIVERY POSITION). IF THE SLIDE IS NOT IN THIS POSITION, FOLLOW INSTRUCTIONS OF THE APPLICATION SPECIFICATION 411-15658

DIMENSIONS CONNECTEUR FERME  
 CLOSED CONNECTOR DIMENSIONS

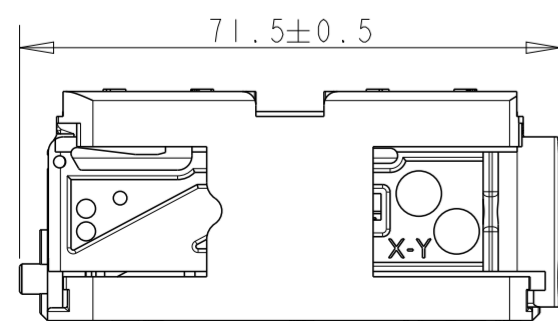

SCALE 1:1

REFERENCES / PART NUMBER

1544551-2

1544551-1

ETRIER OUVERT DU COTE REPERE 1  
 SLIDER OPENED IN CAVITY NUMBER 1 SIDE

ETRIER OUVERT DU COTE REPERE 5  
 SLIDER OPENED IN CAVITY NUMBER 5 SIDE

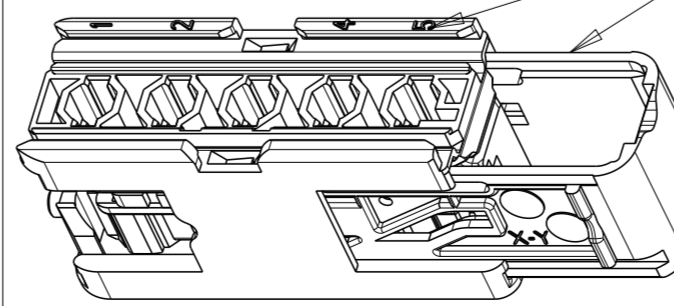
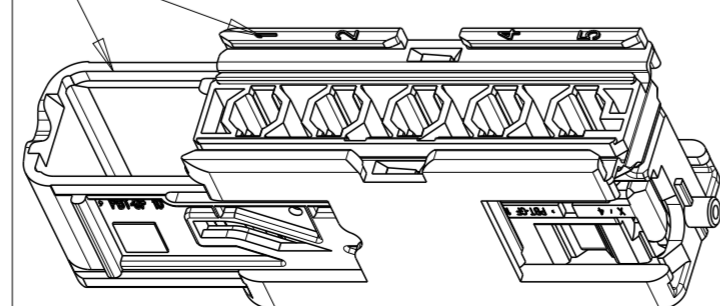

THIS DRAWING IS A CONTROLLED DOCUMENT. / CE PLAN EST UN DOCUMENT CONTROLE PAR TYCO ELECTRONICS. IL EST SUSCEPTIBLE D'ETRE REVISE. CONTACTER LE SERVICE TECHNIQUE DE TYCO ELECTRONICS POUR OBTENIR LA DERNIERE REVISION.

DIMENSIONS:	TOLERANCES UNLESS OTHERWISE SPECIFIED: TOLERANCES NON SPECIFIEES (SUIV NR DE DECIMALES)
mm	±0.2
ANGLES	±2°

MATERIAL/MATIERE: SEE TABLE

DWN /DESSINE	14JUN02
P. FLORES	
CHK /VERIFIE	14JUN02
C. GINET	
APVD /APPROVE	14JUN02
J. DAHER	
PRODUCT SPEC	108-15368
SPEC. PRODUIT	
APPLICATION SPEC	411-15658
SPEC. APPLICATION	
WEIGHT	0.027 kg
MASSSE APPROX.	

		TE Connectivity	
NAME / TITRE: CONNECTEUR 5V CLIPS 6.35NGI CONNECTOR 5 WAY FOR 6.35NGI TERMINAL			
SIZE FORMAT	CAGE CODE	DRAWING NO	RESTRICTED TO RESERVE A
A2	00779	C-1544551	-
CUSTOMER DRAWING	/PLAN CLIENT	UNIQUEMENT POUR REFERENCE	SCALE ECHELLE 2:1
		SHEET FEUILLE	OF DE   REV F

单击下面可查看定价，库存，交付和生命周期等信息

[>>TE Connectivity\(泰科\)](#)