

THIS DRAWING IS UNPUBLISHED. RELEASED FOR PUBLICATION
 © COPYRIGHT BY TYCO ELECTRONICS CORPORATION. ALL RIGHTS RESERVED.

LOC		DIST		REVISIONS			
P	LTR	DESCRIPTION	DATE	DWN	APVD		
B		ECR-08-020124, ADD SHEET 2.	11AUG08	TK	WK		

NOTE:

- MATERIAL:**
 INSERT HOUSING: PA46 WITH 30% GF, UL 94V-0, COLOR: BLACK.
 HOUSING: PA9T WITH 30% GF, UL 94V-0, COLOR: BLACK.
 CONTACTS: PHOSPHOR BRONZE.
 SHELL: BRASS.
- FINISH:**
 CONTACTS: (SEE TABLE) GOLD PLATED ON CONTACT AREA, GOLD FLASH ON SOLDER TAIL, WITH ENTIRE CONTACT UNDERPLATED
 1.27µm [50µ"] MIN. NICKEL.
 SHELL: 0.508µm [20µ"] MIN. NICKEL PLATED.
- REFLOW SOLDER CAPABLE TO 260°C PER TE SPEC 109-201, CONDITION B.

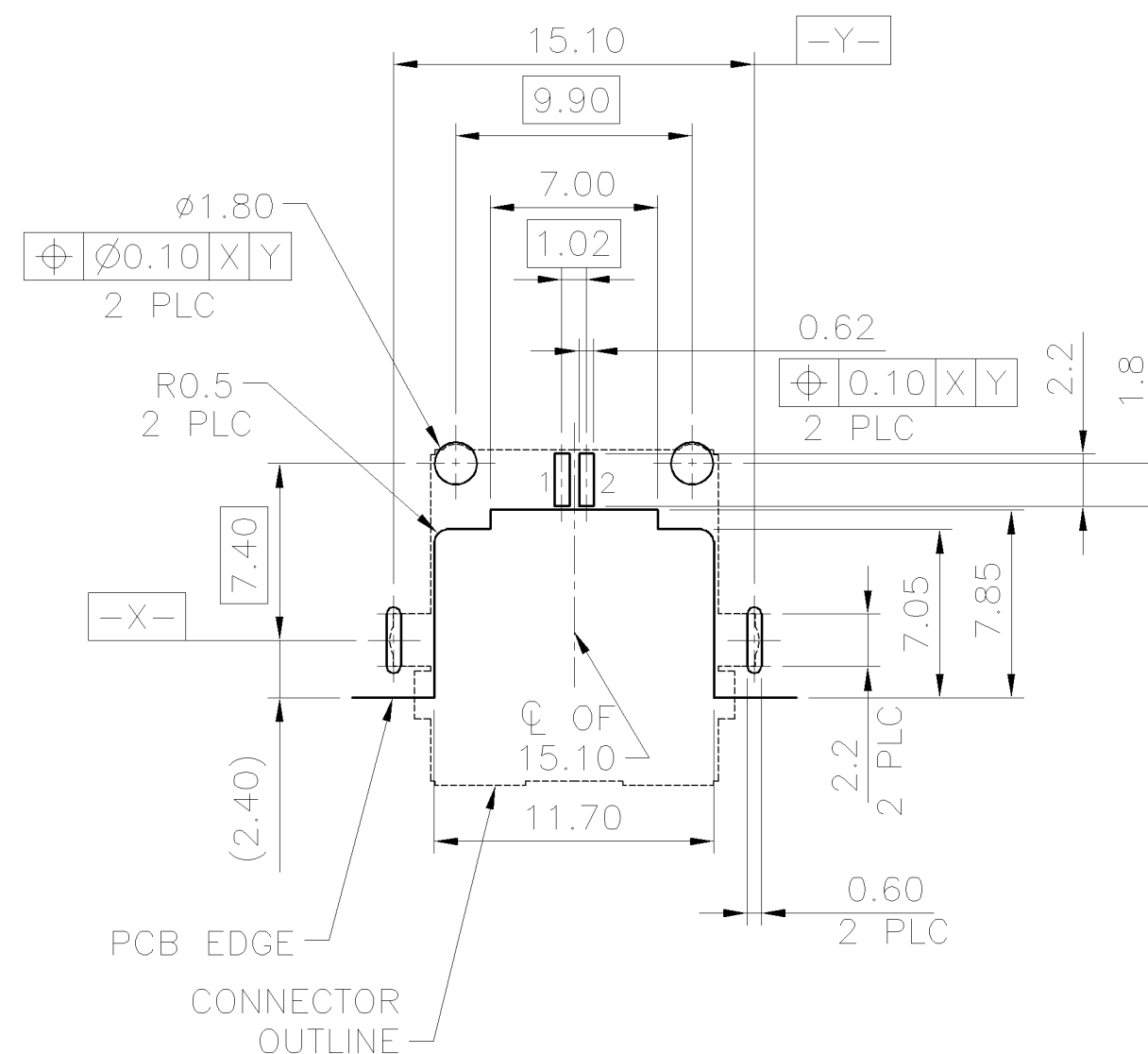
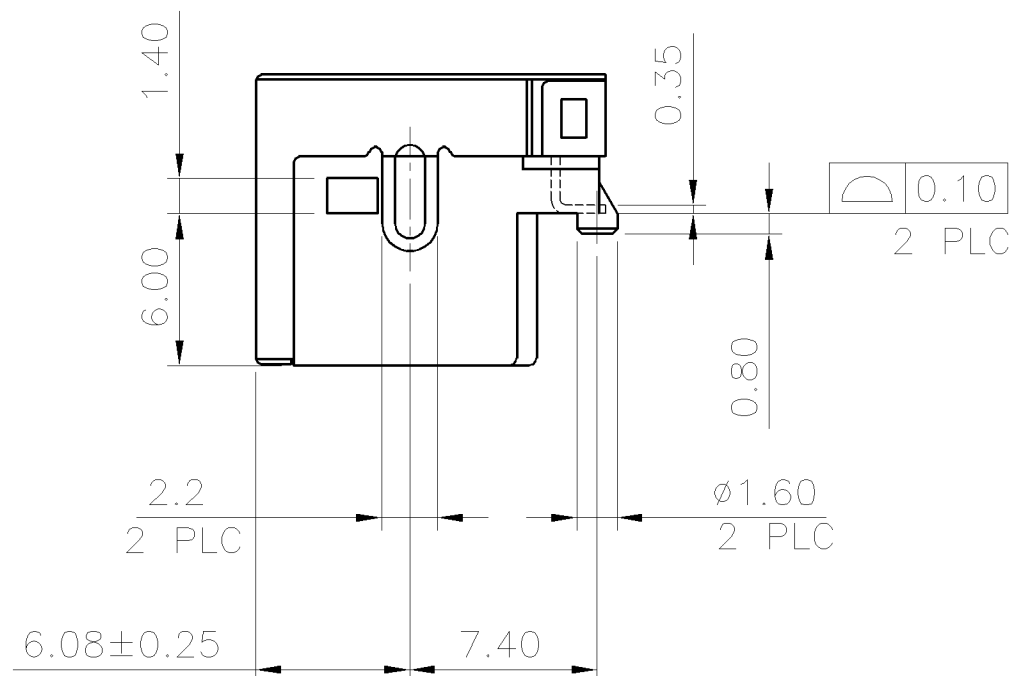
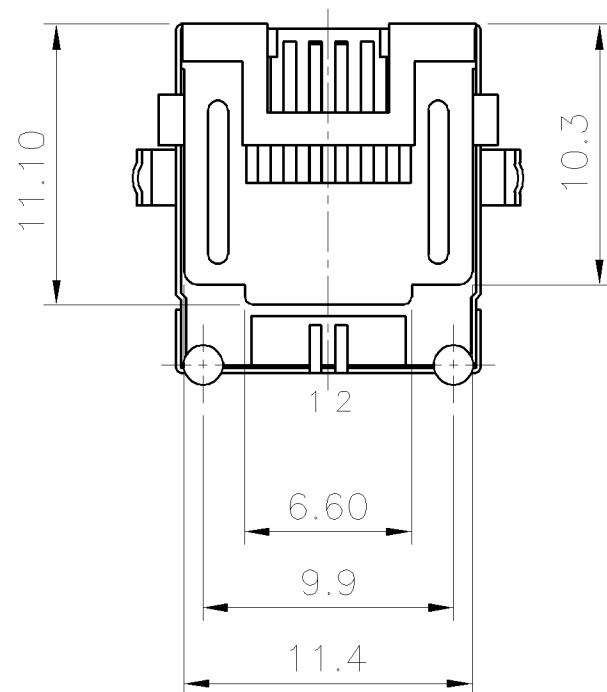
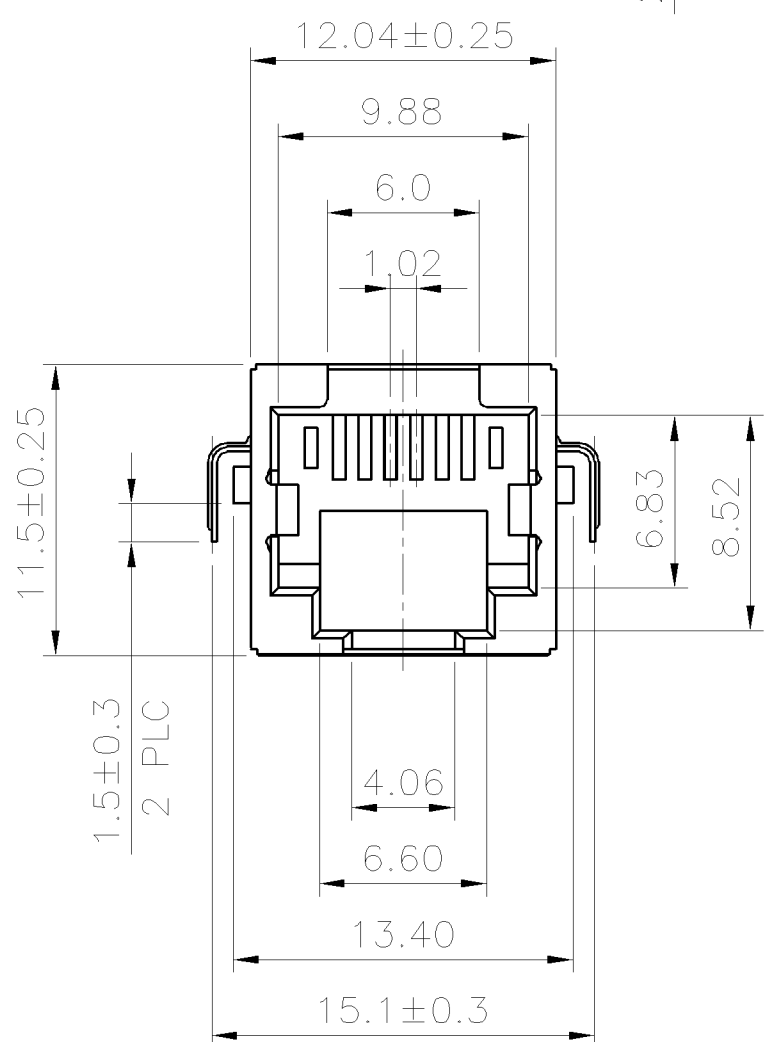
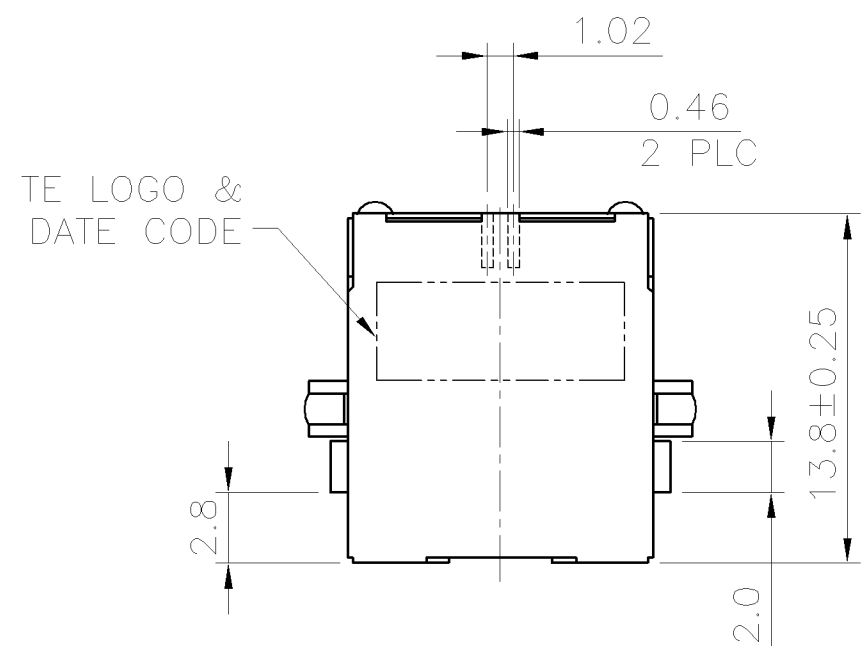

RECOMMENDED PCB LAYOUT (THICKNESS: 1.6mm)
 DIMENSION TOLERANCE: (1 PLC: ±0.1 2PLC: ±0.05)
 TOP VIEW

0.762µm [30µ"]	1759518-1
MIN. GOLD THICKNESS	PART NUMBER

THIS DRAWING IS A CONTROLLED DOCUMENT.		DWN S. HUANG 02JUN2006	Tyco Electronics Corporation Taipei, Taiwan	
DIMENSIONS: MM		CHK S. KOBAYASHI 02JUN2006	NAME	
TOLERANCES UNLESS OTHERWISE SPECIFIED:		APVD W. KODAMA 02JUN2006	MODULAR JACK, RJ11, BOTTOM MOUNT, OFFSET, SMT TYPE.	
0 PLC ± -		PRODUCT SPEC	SIZE	CAGE CODE
1 PLC ± 0.3		APPLICATION SPEC	A2	00779
2 PLC ± 0.25			DRAWING NO	
3 PLC ± 0.15			C=1759518	
4 PLC ± -			RESTRICTED TO	
ANGLES ± 3'				
MATERIAL SEE NOTE	FINISH SEE NOTE	WEIGHT 1.75 GRAMS	SCALE	SHEET
		CUSTOMER DRAWING	-	1 of 3
			REV	B

THIS DRAWING IS UNPUBLISHED. RELEASED FOR PUBLICATION
 © COPYRIGHT BY TYCO ELECTRONICS CORPORATION. ALL RIGHTS RESERVED.

LOC	DIST	REVISIONS			
P	LTR	DESCRIPTION	DATE	DWN	APVD
DW	-	SEE SHEET 1.			

NOTE:

- MATERIAL:
 INSERT HOUSING: PA46 WITH 30% GF, UL 94V-0, BLACK COLOR.
 HOUSING: PA9T 30% GF, UL 94V-0, BLACK COLOR.
 CONTACTS: PHOSPHOR BRONZE.
 SHELL: BRASS.
- FINISH:
 CONTACTS: (SEE TABLE) GOLD PLATED ON CONTACT AREA, GOLD FLASH ON SOLDER TAIL, WITH ENTIRE CONTACT UNDERPLATED
 1.27μm [50μ"] MIN. NICKEL.
 SHELL: 0.508μm [20μ"] MIN. NICKEL PLATED.
- REFLOW SOLDER CAPABLE TO 260°C PER TE SPEC 109-201, CONDITION B.

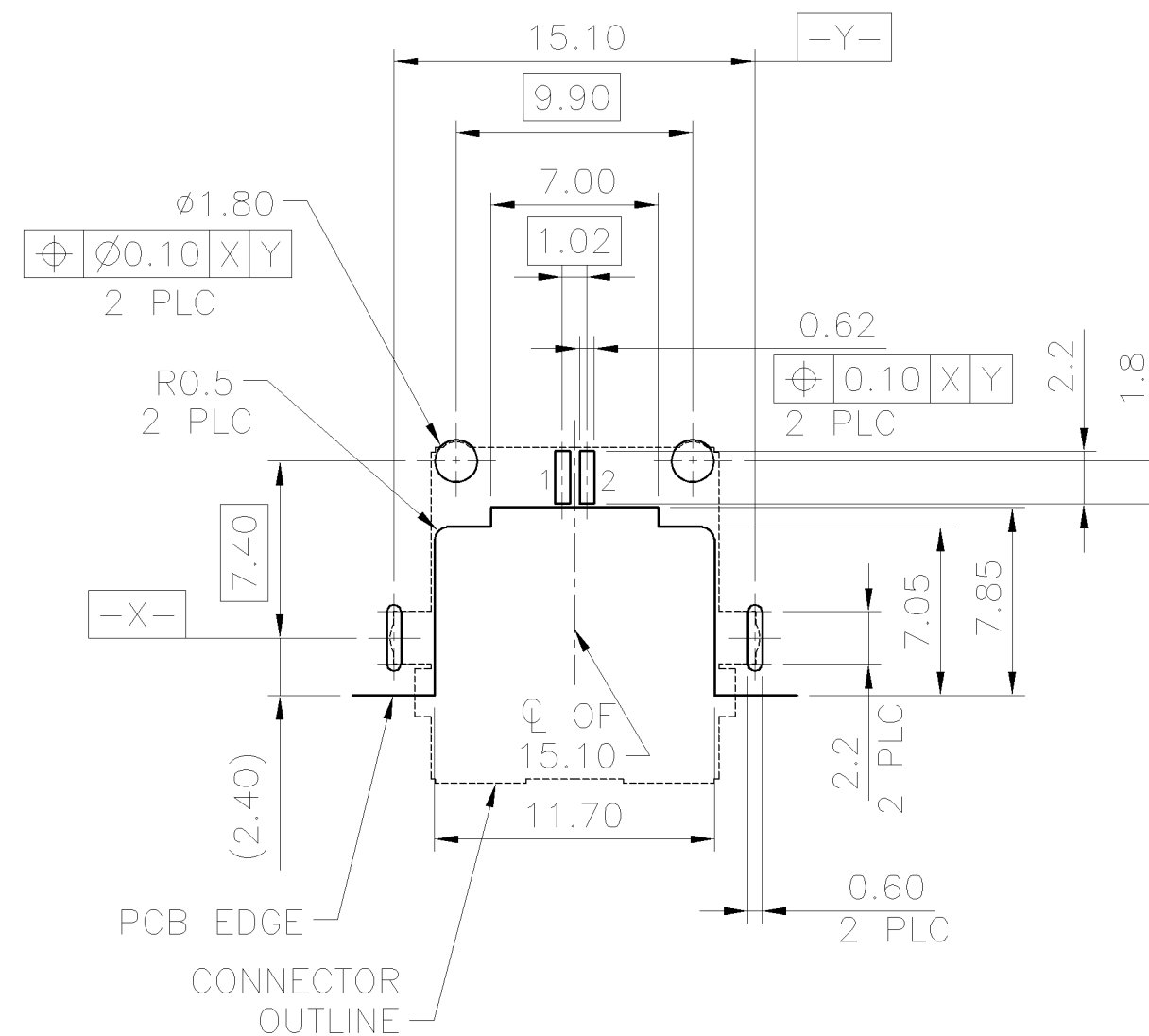
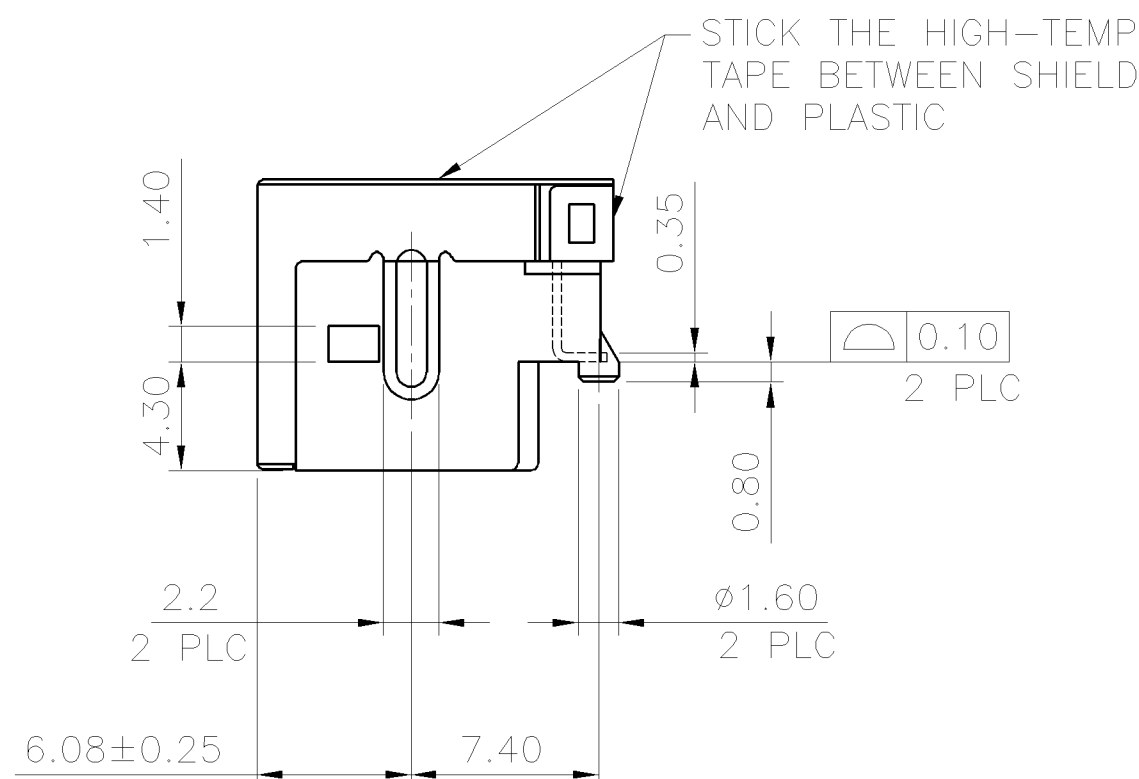
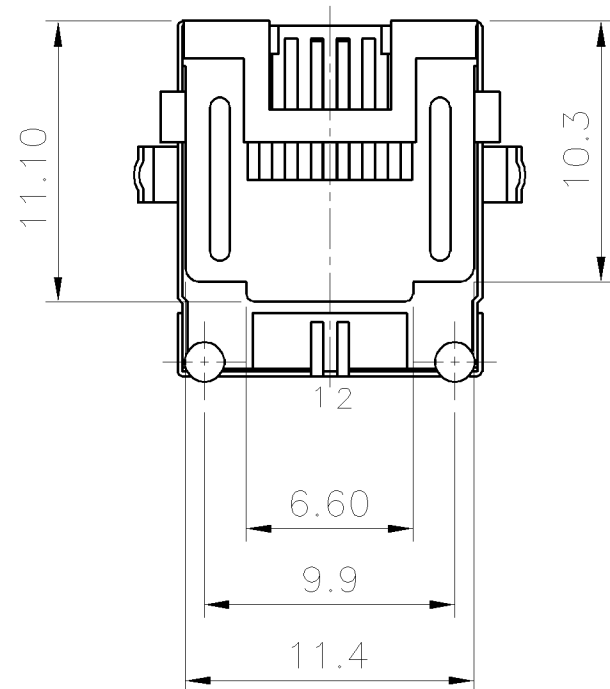
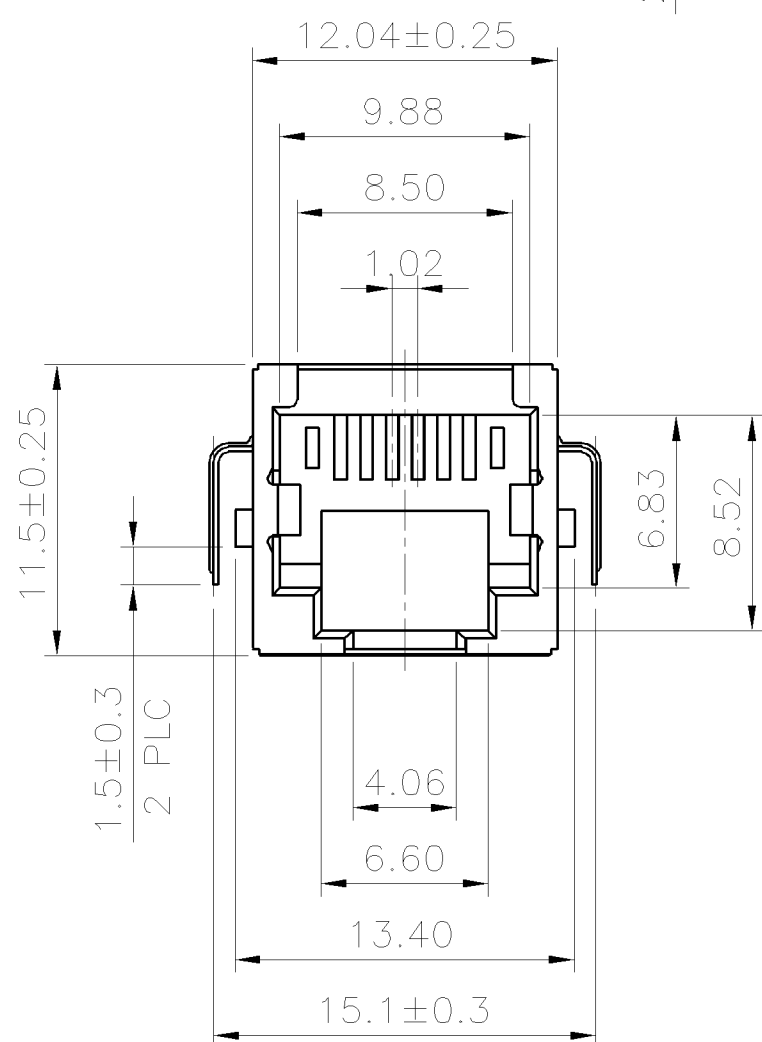
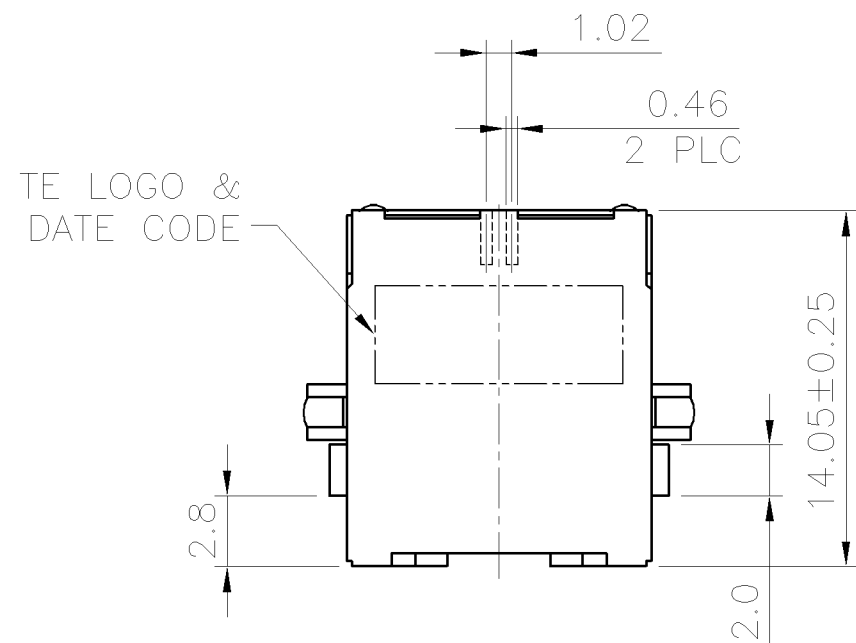

RECOMMENDED PCB LAYOUT (THICKNESS: 1.6mm)
 DIMENSION TOLERANCE: (1 PLC: ±0.1 2PLC: ±0.05)
 TOP VIEW

0.762μm [30μ"]	1759518-2
MIN. GOLD THICKNESS	PART NUMBER

THIS DRAWING IS A CONTROLLED DOCUMENT.		DWN S. HUANG 02JUN2006	Tyco Electronics Corporation Taipei, Taiwan	
DIMENSIONS: MM		CHK S. KOBAYASHI 02JUN2006	NAME MODULAR JACK, RJ11, BOTTOM MOUNT, OFFSET, SMT TYPE.	
TOLERANCES UNLESS OTHERWISE SPECIFIED:		APVD W. KODAMA 02JUN2006	SIZE A2	CAGE CODE 00779
0 PLC ±	1 PLC ±	PRODUCT SPEC	DRAWING NO C=1759518	RESTRICTED TO
2 PLC ±	3 PLC ±	APPLICATION SPEC	SCALE	SHEET 2 of 3
4 PLC ±	ANGLES ±	WEIGHT	REV B	
MATERIAL	FINISH	CUSTOMER DRAWING		

THIS DRAWING IS UNPUBLISHED. RELEASED FOR PUBLICATION
 © COPYRIGHT BY TYCO ELECTRONICS CORPORATION. ALL RIGHTS RESERVED.

LOC	DIST	REVISIONS			
P	LTR	DESCRIPTION	DATE	DWN	APVD
DW	-	SEE SHEET 1.			

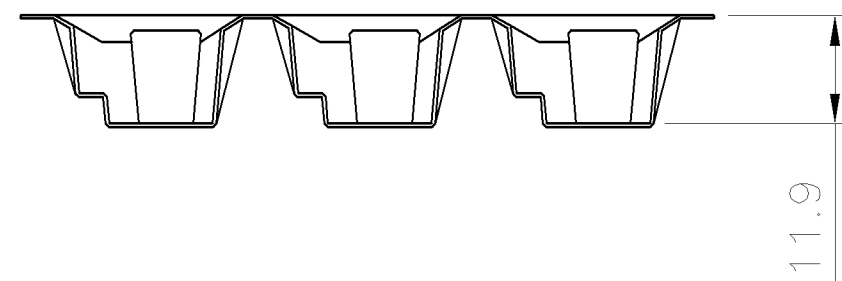
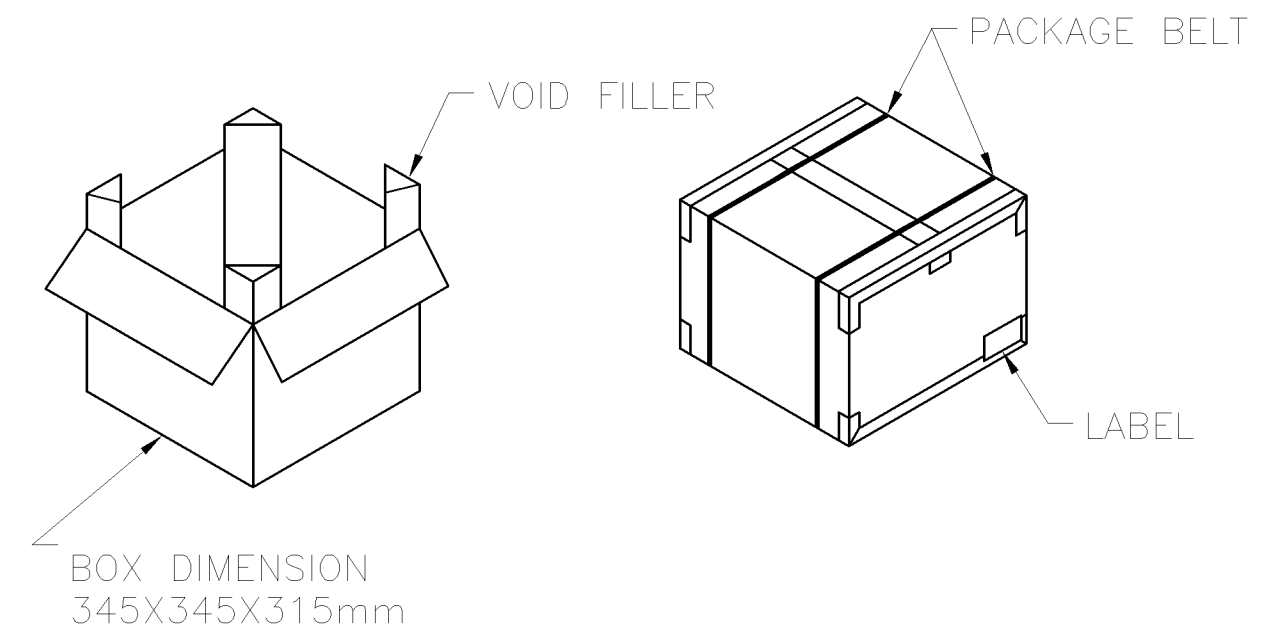
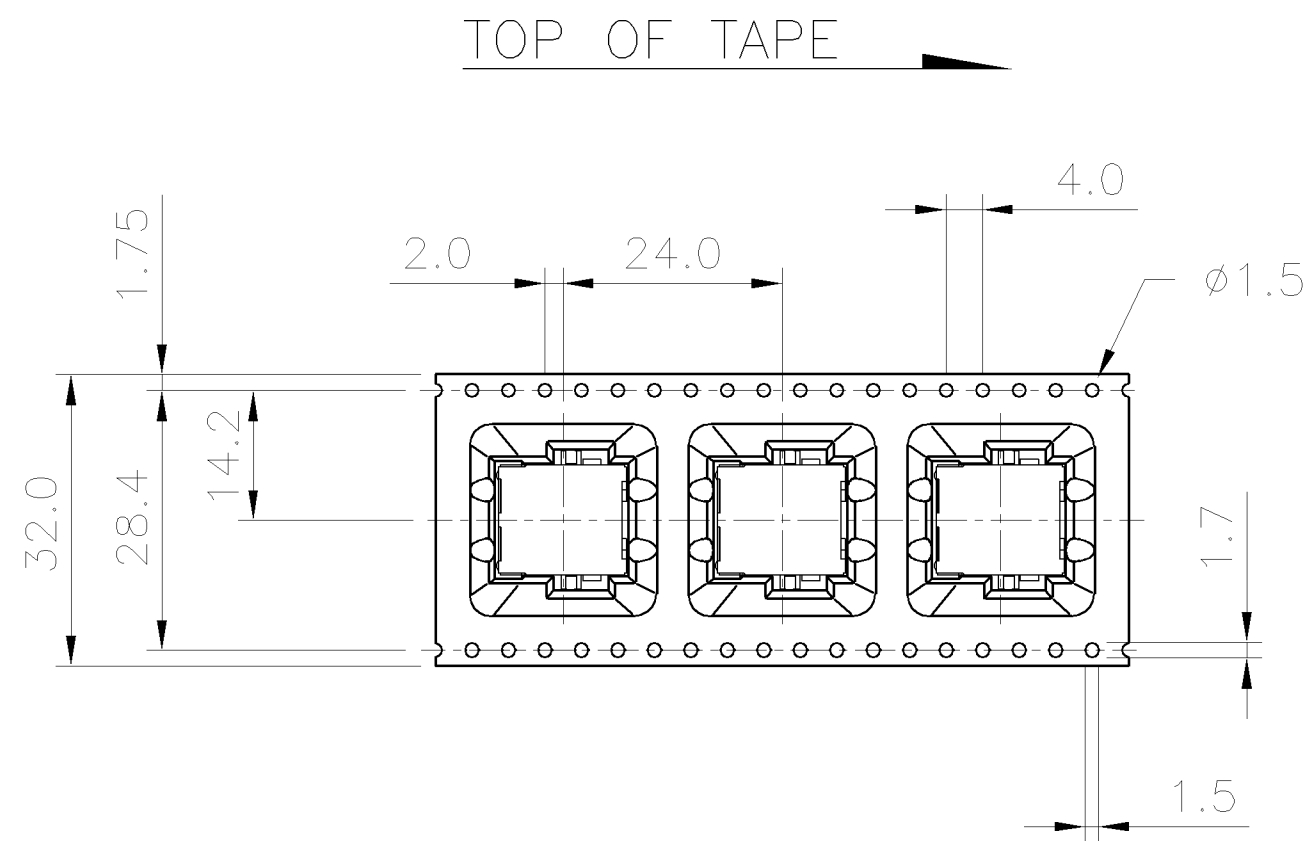
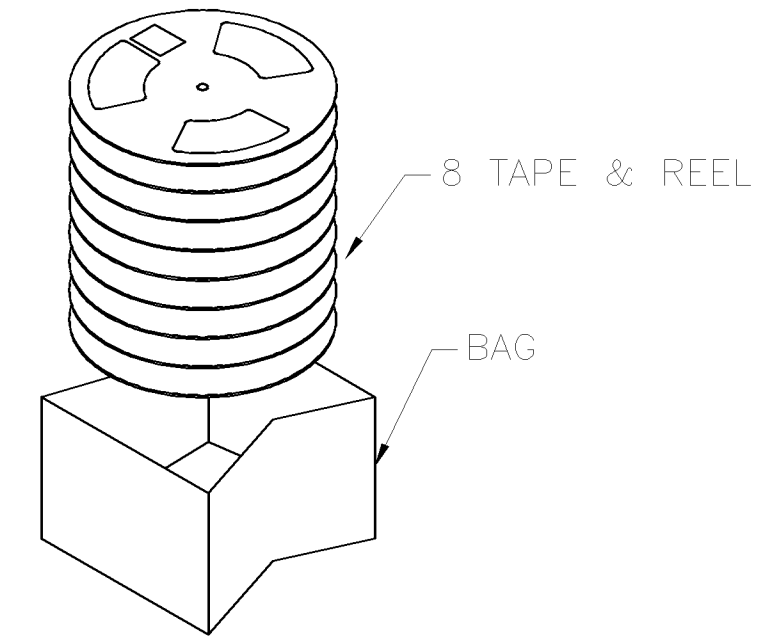
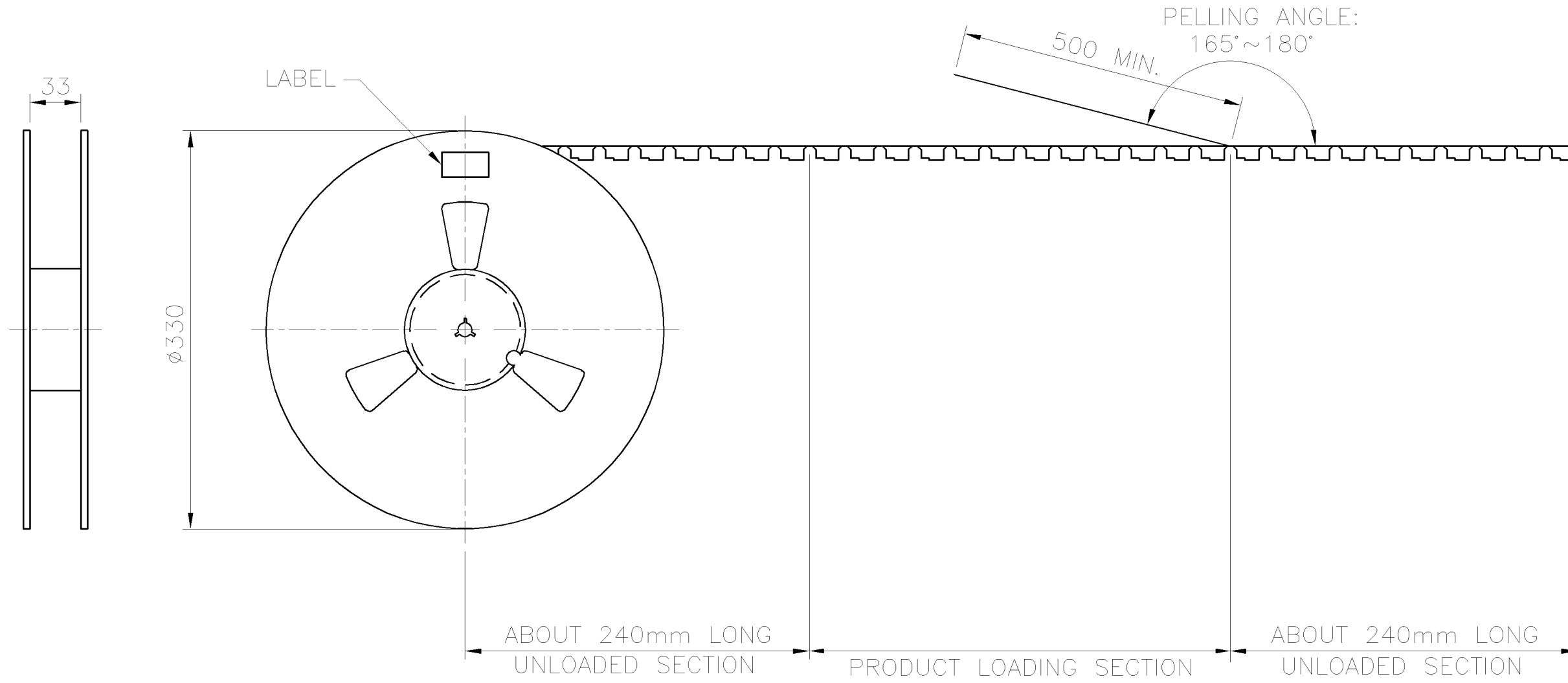

4.8 Kg	2.8 Kg	200	8	1600 PCS
GROSS WEIGHT (REF.)	NET WEIGHT (REF.)	PCS/TAPE	REELS/BOX	QUANTITY

THIS DRAWING IS A CONTROLLED DOCUMENT.		DWN S. HUANG 02JUN2006	Tyco Electronics Corporation Taipei, Taiwan	
DIMENSIONS: MM		CHK S. KOBAYASHI 02JUN2006	NAME	
TOLERANCES UNLESS OTHERWISE SPECIFIED:		APVD W. KODAMA 02JUN2006	MODULAR JACK, RJ11, BOTTOM MOUNT, OFFSET, SMT TYPE.	
0 PLC ± -		PRODUCT SPEC	SIZE A2	CAGE CODE 00779
1 PLC ± -		APPLICATION SPEC	DRAWING NO C=1759518	RESTRICTED TO
2 PLC ± -		WEIGHT -	SCALE -	SHEET 3 of 3
3 PLC ± -		CUSTOMER DRAWING	REV B	
4 PLC ± -				
ANGLES ± -				
FINISH				

单击下面可查看定价，库存，交付和生命周期等信息

[>>TE Connectivity\(泰科\)](#)