

THIS DRAWING IS UNPUBLISHED. RELEASED FOR PUBLICATION
 BY AMP INCORPORATED. ALL RIGHTS RESERVED.

REVISIONS				DATE	DWN	APVD
LOC	DIST	P	LTR	DESCRIPTION		
FT	8	S		REDRAWN W/O CHANGE PER EC 0320-98-96	20 NOV 97	-

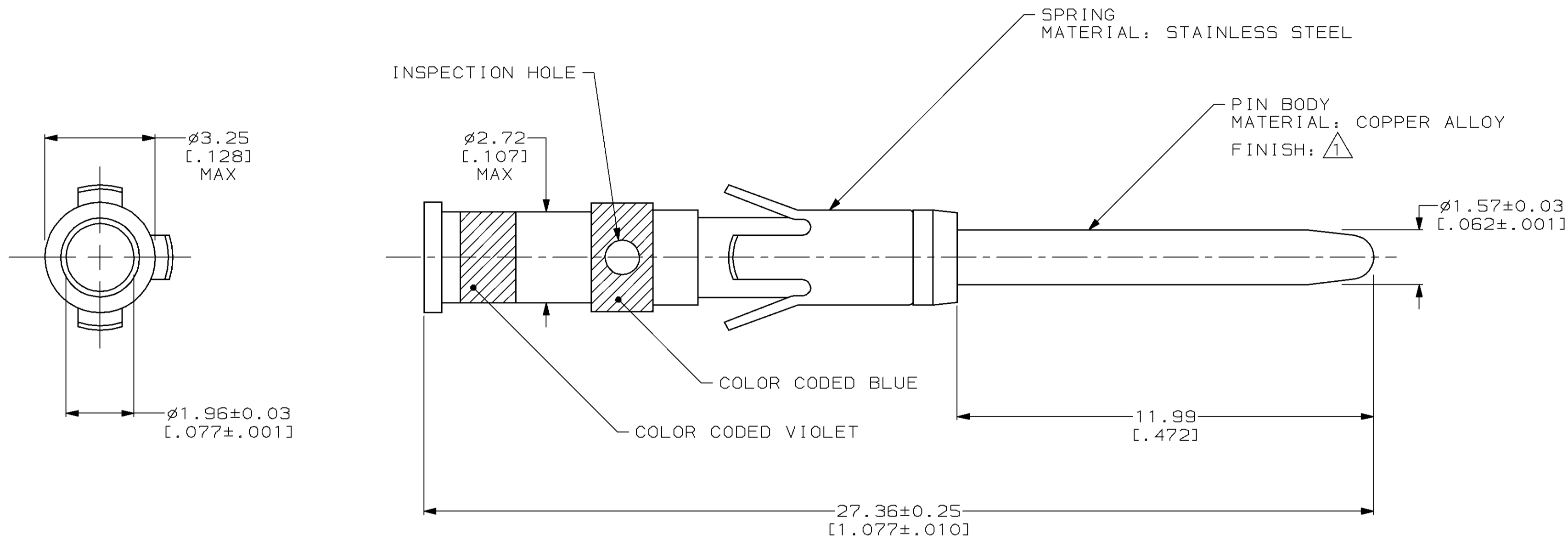

- $\triangle 1$ 0.76 μ m [0.00030] MIN GOLD OVER 1.27 μ m [0.00050] MIN NICKEL.
- $\triangle 2$ WHEN ORDERING CONTACT ASSEMBLY ON TAPE, ORDER BY THE TAPE NUMBER PLUS THE PACKAGING CODE AS FOLLOWS:
 1. FOR USE WITH AMP TAPETRONIC, PNEUMATIC TOOL-
 - A. 1000 PARTS TO A BOX ADD PACKAGING CODE: 1MBOX
 2. FOR USE WITH 4/8 INDENT STRIPPER CRIMPER-
 - A. 1000 PARTS TO A REEL ADD PACKAGING CODE: 1MREEL
 - B. 5000 PARTS TO A REEL ADD PACKAGING CODE: 5MREEL

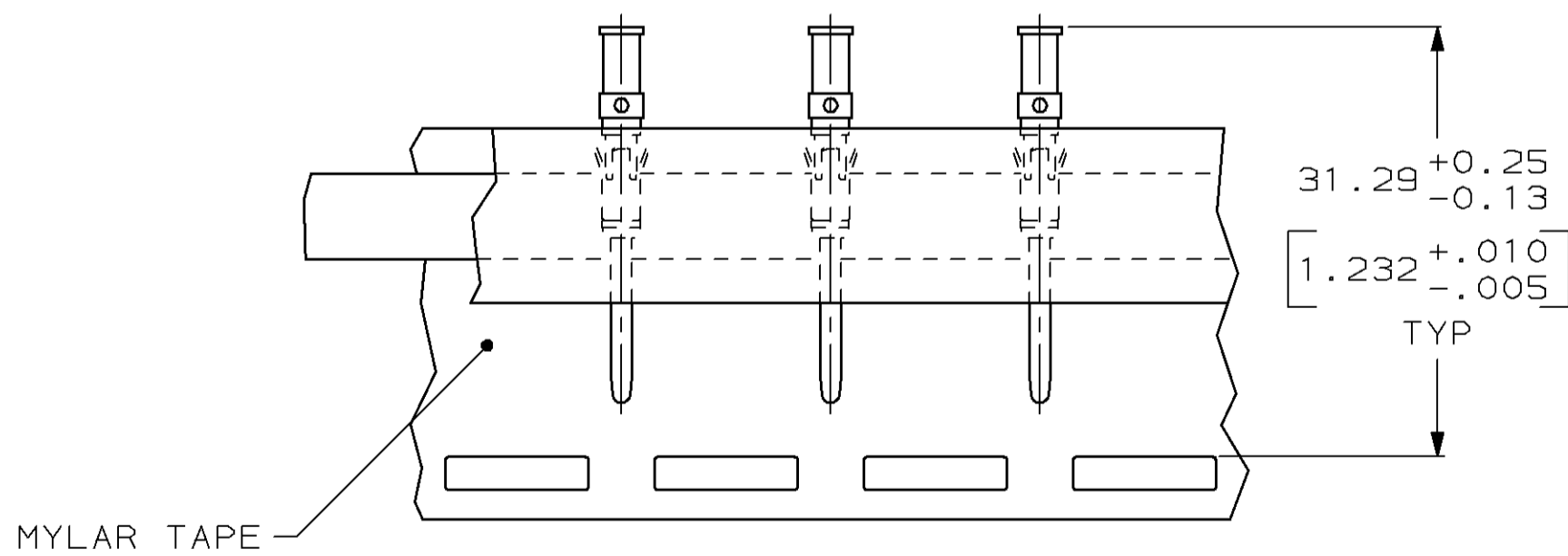

TAPE MTG DETAIL
SCALE 2:1

TAPE MTD $\triangle 2$	201570-2
STANDARD	201570-1
PACKAGING TYPE	PART NUMBER

THIS DRAWING IS A CONTROLLED DOCUMENT.		DWN B. CARBO 20 NOV 97	AMP Incorporated Harrisburg, PA 17105-3608	
DIMENSIONS: mm [INCHES]		CHK R. STONE 09 DEC 97	NAME G. STEINHAUER	
TOLERANCES UNLESS OTHERWISE SPECIFIED:		APVD G. STEINHAUER 16 DEC 97	PRODUCT SPEC	
0 PLC ±-		APPLICATION SPEC		
1 PLC ±-		WEIGHT		
2 PLC ±0.13 [0.005]		SCALE 10:1		
3 PLC ±-		SHEET 1 OF 1		
4 PLC ±-		REV 5		
ANGLES ±-		RESTRICTED TO		
FINISH		A2 00779 $\triangle 2$ 201570		
SEE CALLOUTS		CUSTOMER DRAWING		

单击下面可查看定价，库存，交付和生命周期等信息

[>>TE Connectivity\(泰科\)](#)