

LOC	DIST	ZONE	LTN	DESCRIPTION	DATE	APPD
G	14	A	1	REVISED PER 0720-0230-93		

REVISIONS	
NO.	DESCRIPTION
1	REVISED PER 0720-0230-93

METPRIG
DIMENSIONS LISTED IN mm [INCHES]

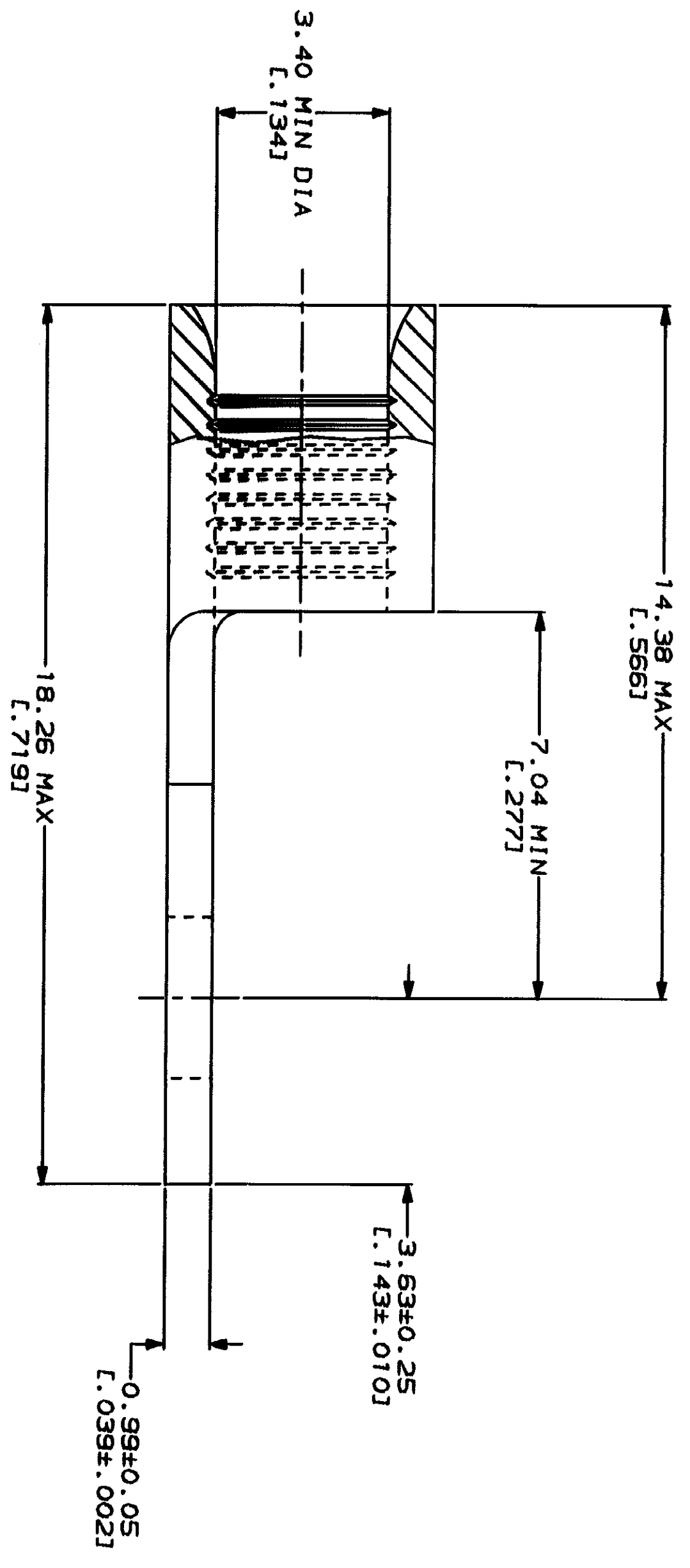
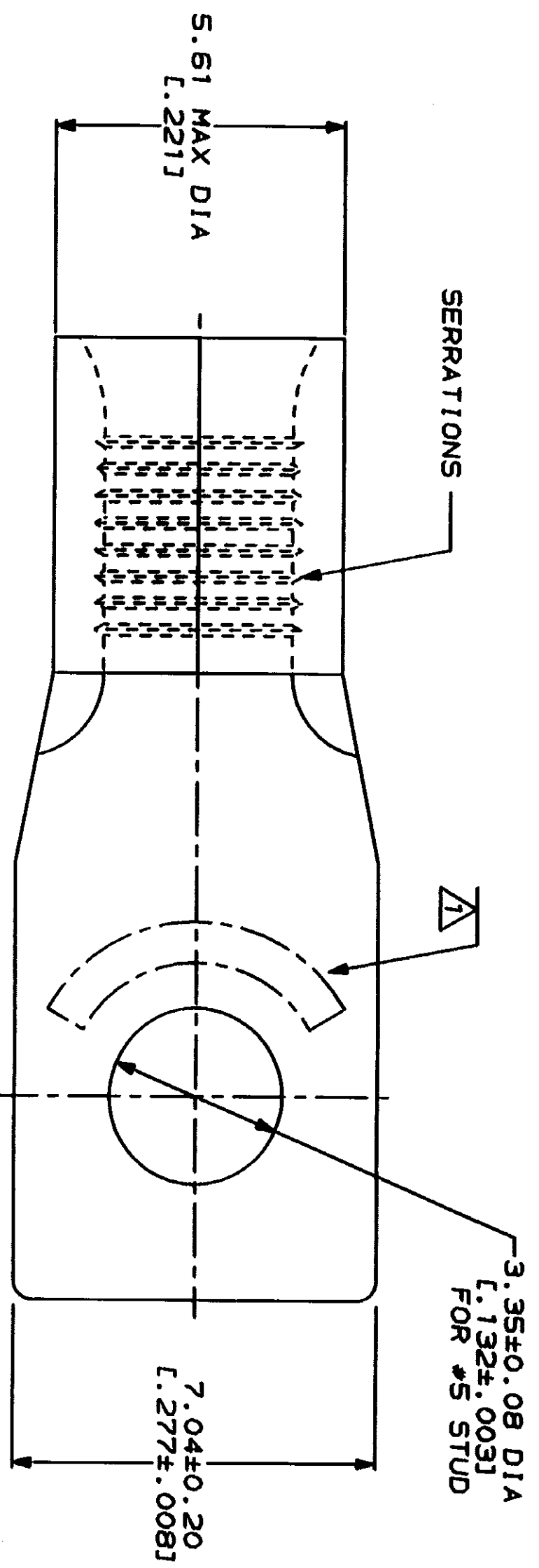

AMP WIRE RANGE 12-10 AWG STRANDED	UL E13288 Listed
● LRT189 Certified	MILITARY P/N AND CLASS
NOT CERTIFIED	NOT APPLICABLE

△ STAMP AMP 12-10* APPROX AS SHOWN

**AMP INCORPORATED
CUSTOMER SERVICE SYSTEMS**

FOR ADDITIONAL
PRODUCT INFORMATION OR
COPIES OF DRAWINGS
AND TECHNICAL DOCUMENTS
1-800-522-6752

FOR APPLICATION
TOOLING INFORMATION
1-800-722-1111

FOR ORDER ENTRY
1-800-526-5142

MAX RECOMMENDED OPERATING
TEMPERATURE:
170°C MAX

VOLTAGE RATING:
NOT APPLICABLE

WIRE CROSS SECTIONAL AREA RANGE:
2.62-6.64mm² [S, 180-13, 100] CIR MILS
STRANDED

THIS DRAWING IS A CONTROLLED DOCUMENT FOR
USE ONLY BY THE CUSTOMER. IT IS THE CUSTOMER'S
RESPONSIBILITY TO CONTROL THE DOCUMENT AND
REVISIONS FOR THE LATEST VERSION.

DO NOT SCALE PRINT.
UNLESS SPECIFIED
DIMENSIONS IN mm [INCHES]
TOLERANCES ON:
2 PLC DEC ±
3 PLC DEC ±
ANGLES ±

MATERIAL
COPPER PER
ASTM B-152
ANNEALED

FINISH
TIN PLATE
0.00254 [0.000100] MIN
THK PER MIL-T-10727

DR 1-28-93
TA BRINKMAN

CHK 1-28-93
DA PATTERSON

APPD 1-28-93
DE MILLER

APPD 1-28-93
JL HECKLEY

PRODUCT SPEC

APPLICATION SPEC

AMP
AMP Incorporated
Harrisburg, PA 17105-3608

TERMINAL, RECTANGULAR
TONGUE, BUDGET

SIZE
CAGE CODE
00779

SCALE 10:1

DRAWING NO
327953

327953
PART NO

单击下面可查看定价，库存，交付和生命周期等信息

[>>TE Connectivity\(泰科\)](#)