

REVISIONS			
LTR	DESCRIPTION	DATE	APPROVED
U1	REVISED PER ECO-11-005139	20APR11	HMR

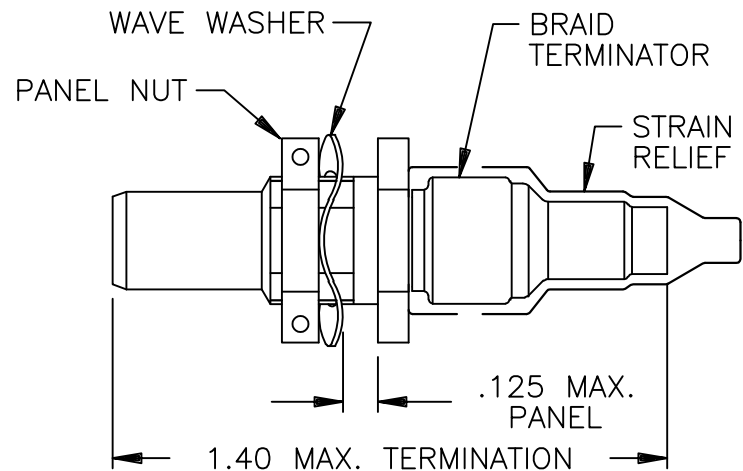

PLUG ASSEMBLY: D-621-0011

JACK ASSEMBLY: D-621-0012

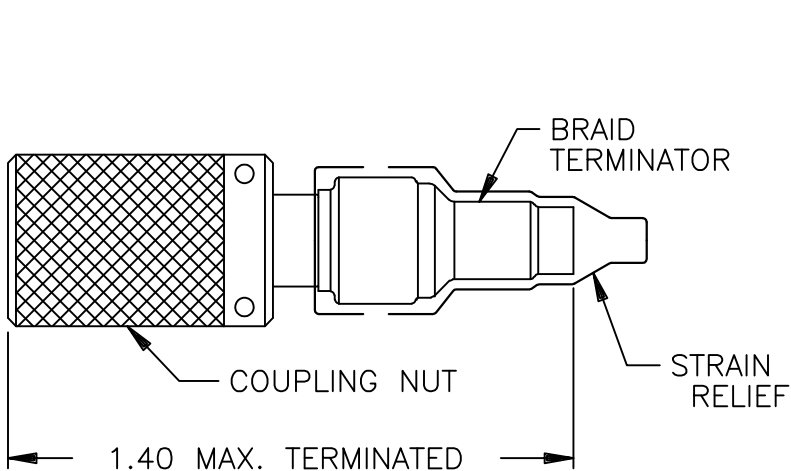
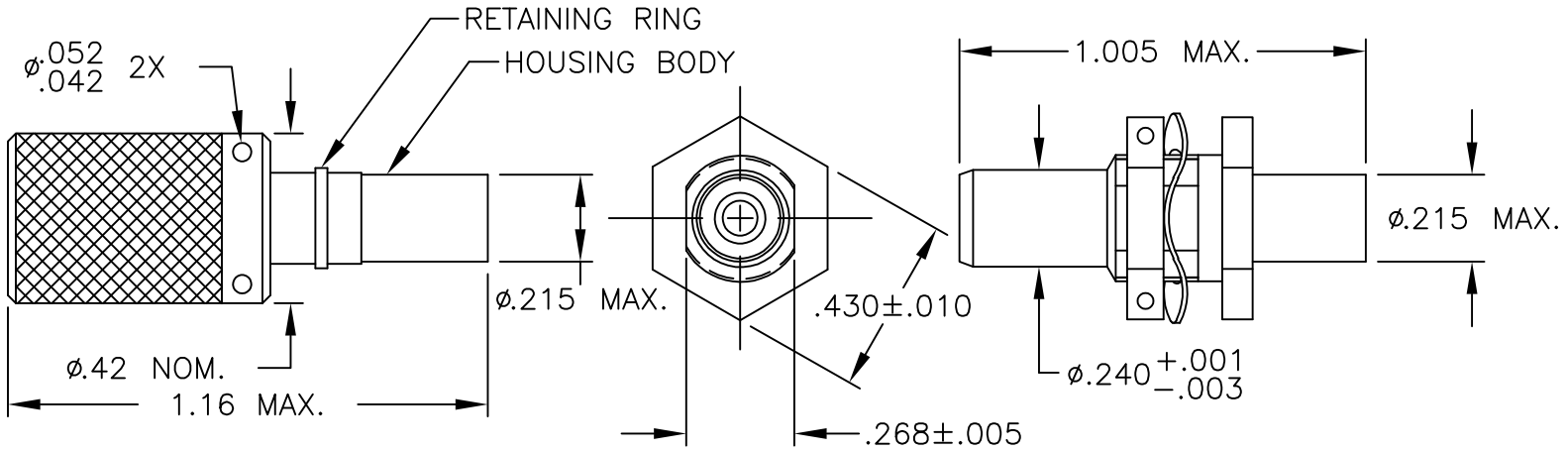
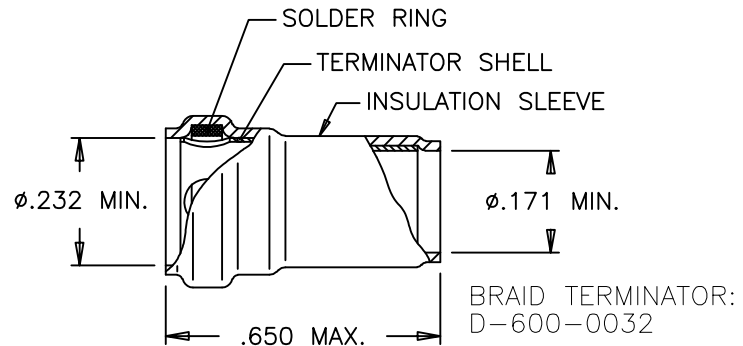
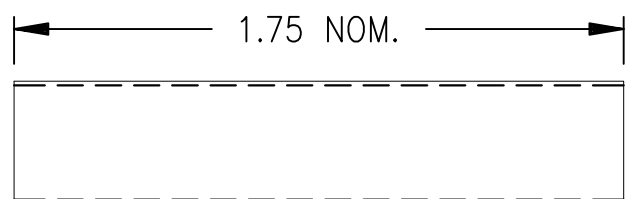

STRAIN RELIEF: D-600-0019

IF THIS DOCUMENT IS PRINTED IT BECOMES UNCONTROLLED. CHECK WITH THE WEB FOR LATEST REVISION.

SPECIFICATION CONTROL DRAWING

UNLESS OTHERWISE SPECIFIED DIMENSIONS ARE IN INCHES. METRIC DIMENSIONS ARE IN BRACKETS.

DECIMALS
.XXX ± — [— mm]
.XX ± — [— mm]

ANGLES
.X ± —

WEIGHT
— lbs [— g]

DRAWN	J.B.K.	90 NOV 15
CHECKED		
APPROVED		
APPROVED	Z.TEMAN	90 NOV 30
CAD NAME	004996-1.DWG	

STE TE Connectivity **Raychem** TE CONNECTIVITY
300 CONSTITUTION DRIVE
MENLO PARK, CALIFORNIA 94025

TITLE
CONNECTOR, TRIAXIAL,
SUBMINIATURE,
THREADED COUPLE

THIRD ANGLE PROJECTION	SIZE	CODE IDENT. NO.	DWG. NO.	REV
	A	004996	D-621-0011/0012	U1
	DO NOT SCALE THIS DRAWING			SHEET 1 OF 2

1.0 MATERIALS AND FINISHES

- 1.1 HOUSING BODY (PLUG): BRASS ALLOY PER ASTM B16,
TIN PLATED PER MIL-T-10727 TYPE I,
OVER NICKEL PER MIL-C-26074
- (JACK): BeCu ALLOY, ASTM B196, TB00 OR TD04,
TIN PLATED PER MIL-T-10727 TYPE I,
OVER NICKEL PER MIL-C-26074
- 1.1.1 INSULATION (MIP): POLYETHERSULFONE
- 1.2 COUPLING NUT (PLUG): BRASS ALLOY PER ASTM B16,
NICKEL PLATED PER QQ-N-290
- 1.3 PANEL NUT (JACK): BRASS ALLOY PER ASTM B16,
NICKEL PLATED PER QQ-N-290
- 1.4 WAVE WASHER (JACK): BECU PER ASTM B194 NT 180K TS
NICKEL PLATED PER QQ-N-290
- 1.5 BRAID TERMINATOR
- 1.5.1 BODY: BRASS ALLOY PER ASTM B16, TIN-LEAD PLATED
PER MIL-P-81728A, OVER NICKEL PER QQ-N-290
- 1.5.2 SOLDER PREFORM: Sn63Pb37 PER QQ-S-571
- 1.5.3 INSULATION SLEEVE: POLYVINYLIDENE FLUORIDE
- 1.6 STRAIN RELIEF: WHITE TAT-125 (RNF-100 WITH ADHESIVE)

2.0 CONTACTS

CABLE TYPE	TRIAxIAL	TWINAXIAL	COAXIAL
CONTACT(S)	D-602-44 (PIN) D-602-45 (SOCKET)	D-602-0126 (PIN) D-602-0127 (SOCKET)	D-610-09 (PIN) D-610-10 (SOCKET)

3.0 SEE ES61162 FOR CABLE ACCOMODATION AND TERMINATION INFORMATION.

4.0 PERFORMANCE REQUIREMENTS

4.1 REFER TO RAYCHEM SPECIFICATION D-6025 FOR PRODUCT PERFORMANCE AND QUAILIFICATION REQUIREMENTS.

5.0 GENERAL CHARACTERISTICS

- 5.1 OPERATING TEMPERATURE: -65°C TO 125°C
- 5.2 INSULATION RESISTANCE: GREATER THAN 5K MEG
- 5.3 DIELECTRIC STRENGTH: 900 VAC @ 60 Hz
- 5.4 CURRENT RATING: 3 AMPS MAX.
- 5.5 CONTACT RESISTANCE: INITIAL: 8 MILLIOHMS MAX.
- 5.6 MATING COUPLING TORQUE: 10 INCH/LBS MAX.
- 5.7 PANEL NUT TORQUE (JACK): 10-15 INCH/LBS (WHEN INSTALLING IN PANEL)

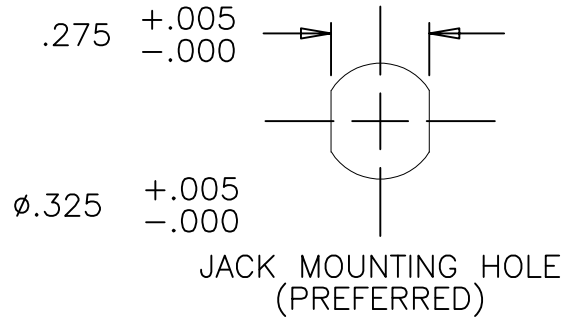

IF THIS DOCUMENT IS PRINTED IT BECOMES UNCONTROLLED.
CHECK WITH THE WEB FOR LATEST REVISION.

CAD NAME: 004996-2	DRAWN	J.B.K.	90 NOV 15	SIZE	CODE IDENT. NO.	DWG. NO.	REV.
	ISSUED			Λ	004990	D-621-0011/0012	U1
				Downloaded From Oneyac.com			
				DO NOT SCALE THIS DRAWING		SHEET 2 OF 2	

单击下面可查看定价，库存，交付和生命周期等信息

[>>TE Connectivity\(泰科\)](#)