

THIS DRAWING IS UNPUBLISHED. RELEASED FOR PUBLICATION - N/A .
 © COPYRIGHT N/A BY TYCO ELECTRONICS CORPORATION. ALL RIGHTS RESERVED.

LOC	DIST	REVISIONS			
P	LTR	DESCRIPTION	DATE	DWN	APVD
DF	X0	E	REV PER 0H14-0244-05	04-05	AA RG

ASSEMBLED VIEW

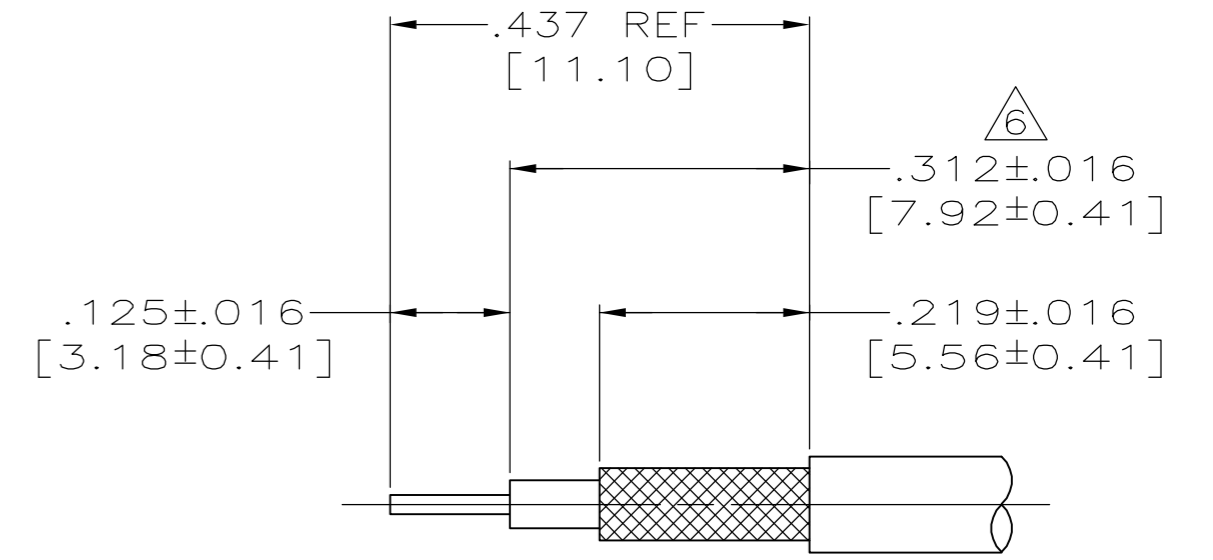
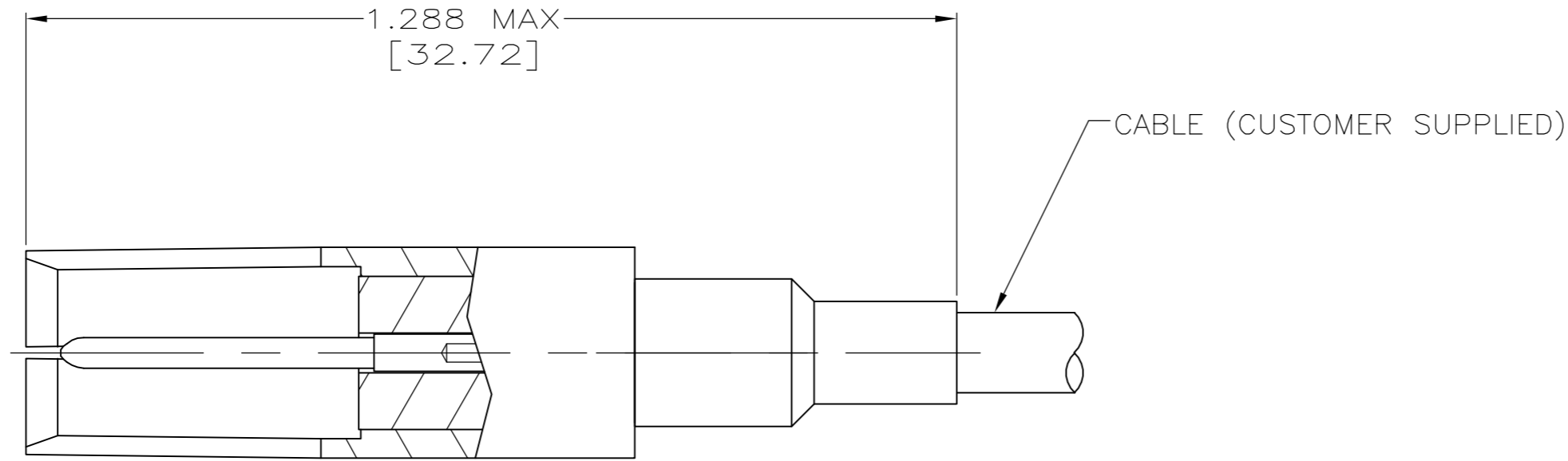

RECOMMENDED STRIP LENGTH
SCALE: N.T.S.

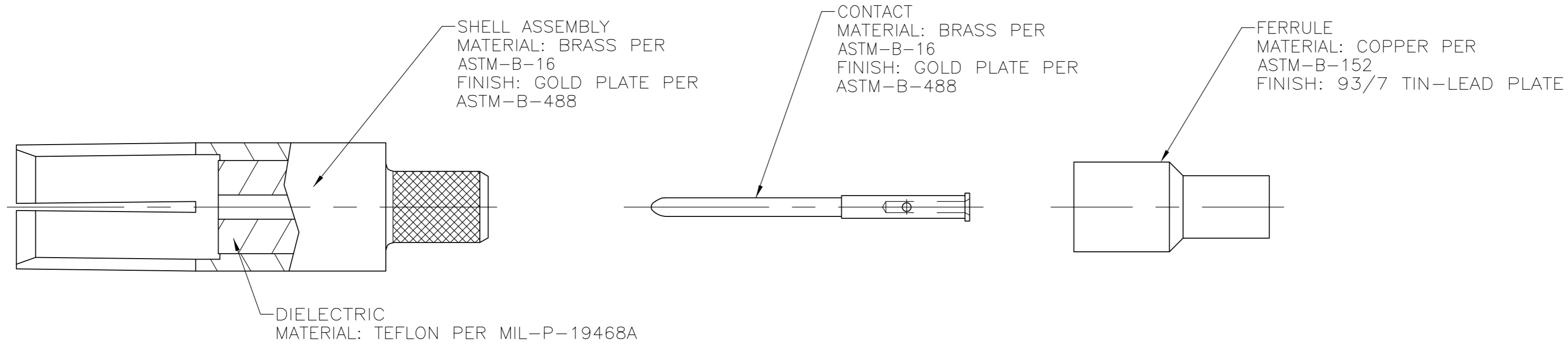

- FOR USE WITH RG-179/U OR 187/U CABLE.
- FERRULE CRIMPING TOOL: AMP TOOL 220066-1, CRIMP C.
- CONTACT CRIMPING TOOL: M22520/2-01 OR AMP TOOL NUMBER 1-601966-6, SETTING NUMBER 5. DANIELS POSITIONER PART NO. K345 OR AMP TOOL NO. 1-601966-6.
- SEE I.S.2348.
- DANIELS MANUFACTURING CORP
2266 FRANKLIN ROAD
BLOOMFIELD HILLS, MI 48013

- 6 OUTER JACKET OF CABLE MUST BE TRIMMED TO ALLOW PROPER INTER-PIN CONTACT LOCATION AFTER FERRULE CRIMP OPERATION.
- PARTS SHIPPED UNASSEMBLED AND CABLE IS SUPPLIED BY CUSTOMER.

225791-4
PART NO.

THIS DRAWING IS A CONTROLLED DOCUMENT.		DWN	12-SEP-94	 Tyco Electronics Corporation Harrisburg, Pa 17105-3608
DIMENSIONS: INCHES		CHK	23-SEP-94	
TOLERANCES UNLESS OTHERWISE SPECIFIED:		APVD	23-SEP-94	
0 PLC ± - 1 PLC ± - 2 PLC ± - 3 PLC ± - 4 PLC ± - ANGLES ± -		NAME	J.CARBALO	
MATERIAL SEE CALLOUTS		FINISH	SEE CALLOUTS	PRODUCT SPEC APPLICATION SPEC WEIGHT -
		SIZE A2 CAGE CODE 00779 DRAWING NO. C=225791-4		RESTRICTED TO -
		CUSTOMER DRAWING		SCALE 5:1 SHEET 1 OF 1 REV E

单击下面可查看定价，库存，交付和生命周期等信息

[>>TE Connectivity\(泰科\)](#)