

THIS DRAWING IS UNPUBLISHED. RELEASED FOR PUBLICATION  
 © COPYRIGHT - By - ALL RIGHTS RESERVED.

LOC	DIST	REVISIONS					
DF	S5	P	LTR	DESCRIPTION	DATE	DWN	APVD
		D		REV PER ECO-12-009412	21JUN12	PY	DE

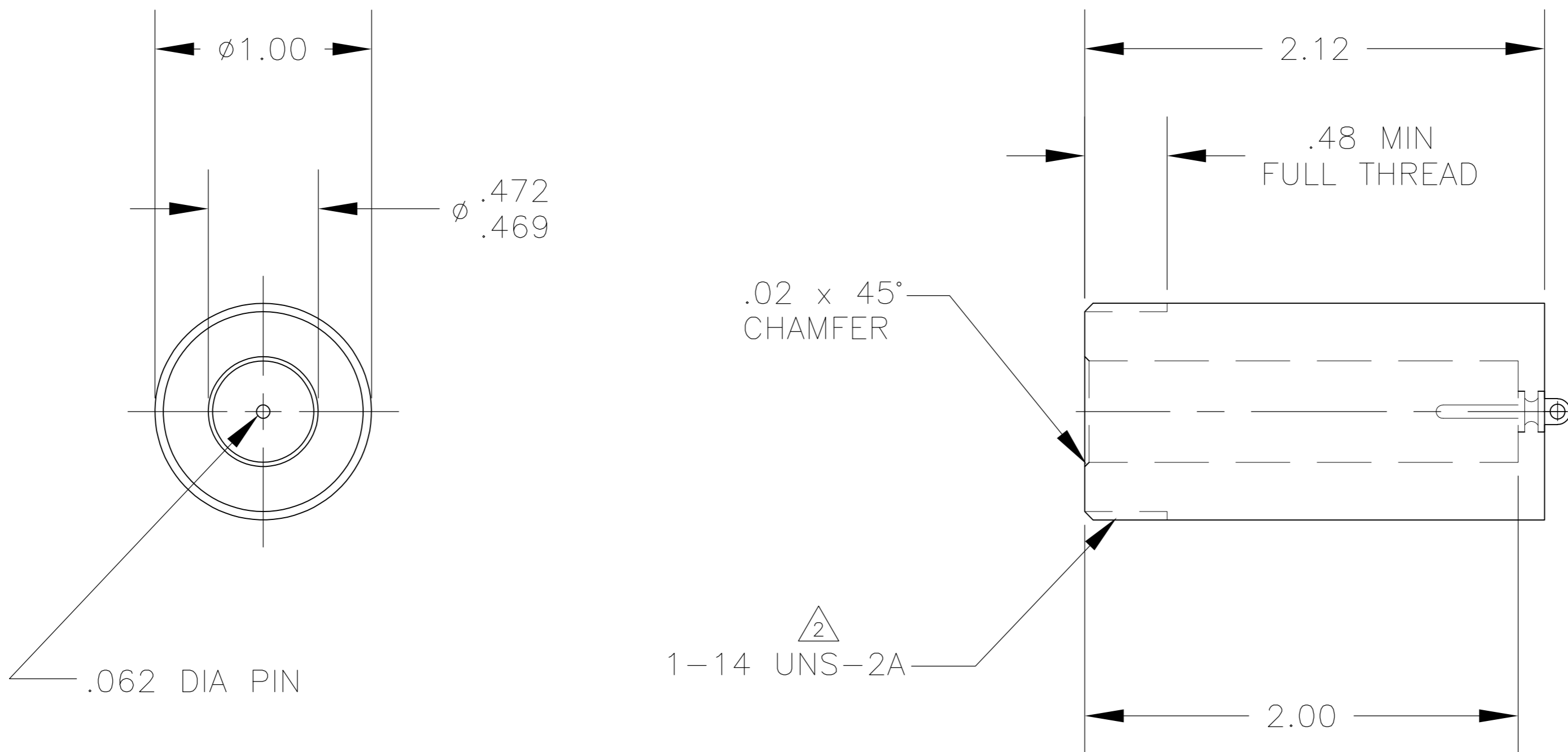

1. RECEPTACLE TO MATE WITH AMP LGH 4 LEAD ASSEMBLY, AVAILABLE SEPARATELY

△ PER FEDERAL STANDARD H-28, 3-WIRE METHOD. DIMENSION OVER WIRES TO BE .9975-1.0186

AS SHOWN WITH TIN PLATED PIN PER ASTM-B-545, .0001 THK		5-836567-1
AS SHOWN WITH GOLD PLATED PIT PER MIL-G-45024, TYPE II, CLASS 3		836567-2
AS SHOWN WITH 93/7 TIN-LEAD PLATED PIN, .0001 THK		836567-1
DESCRIPTION		PART NO
THIS DRAWING IS A CONTROLLED DOCUMENT.		DWN P. YEAGER 31JAN06
DIMENSIONS: INCHES		CHK D. EABY 01FEB06
TOLERANCES UNLESS OTHERWISE SPECIFIED:		APVD D. EABY 01FEB06
0 PLC ± -		NAME
1 PLC ± -		RECEPTACLE ASSEMBLY
2 PLC ± .02		LGH-4 (FOR POTTED UNITS)
3 PLC ± .005		SIZE
4 PLC ± -		CAGE CODE
ANGLES ± -		DRAWING NO
MATERIAL MOLDED GLASS EPOXY		RESTRICTED TO
FINISH BLACK		A2 00779 C-836567
WEIGHT -		SCALE 4:1
CUSTOMER DRAWING		SHEET 1 of 1
		REV D

单击下面可查看定价，库存，交付和生命周期等信息

[>>TE Connectivity\(泰科\)](#)