

THIS DRAWING IS UNPUBLISHED. RELEASED FOR PUBLICATION
 © COPYRIGHT - By - ALL RIGHTS RESERVED.

LOC		DIST		REVISIONS			
P	LTR	DESCRIPTION	DATE	DWN	APVD		
GP	00	Z1	REVISED PER ECO-11-004835	11MAR11	RK	HMR	

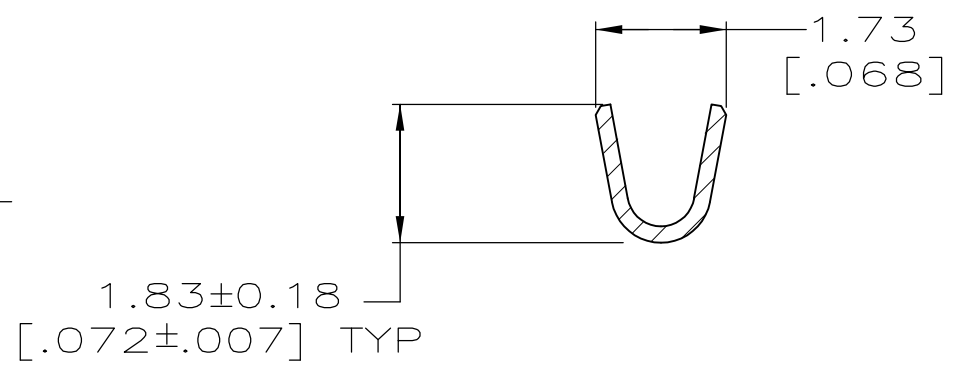
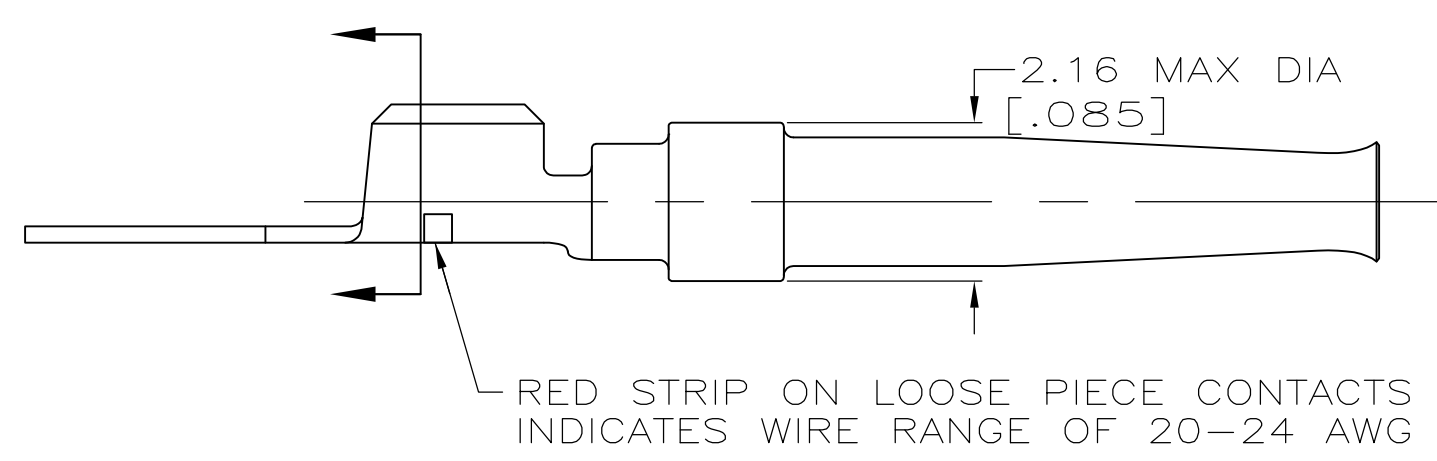
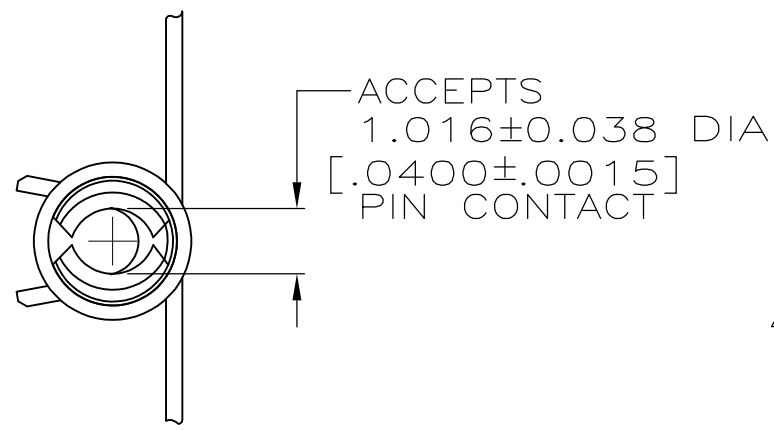
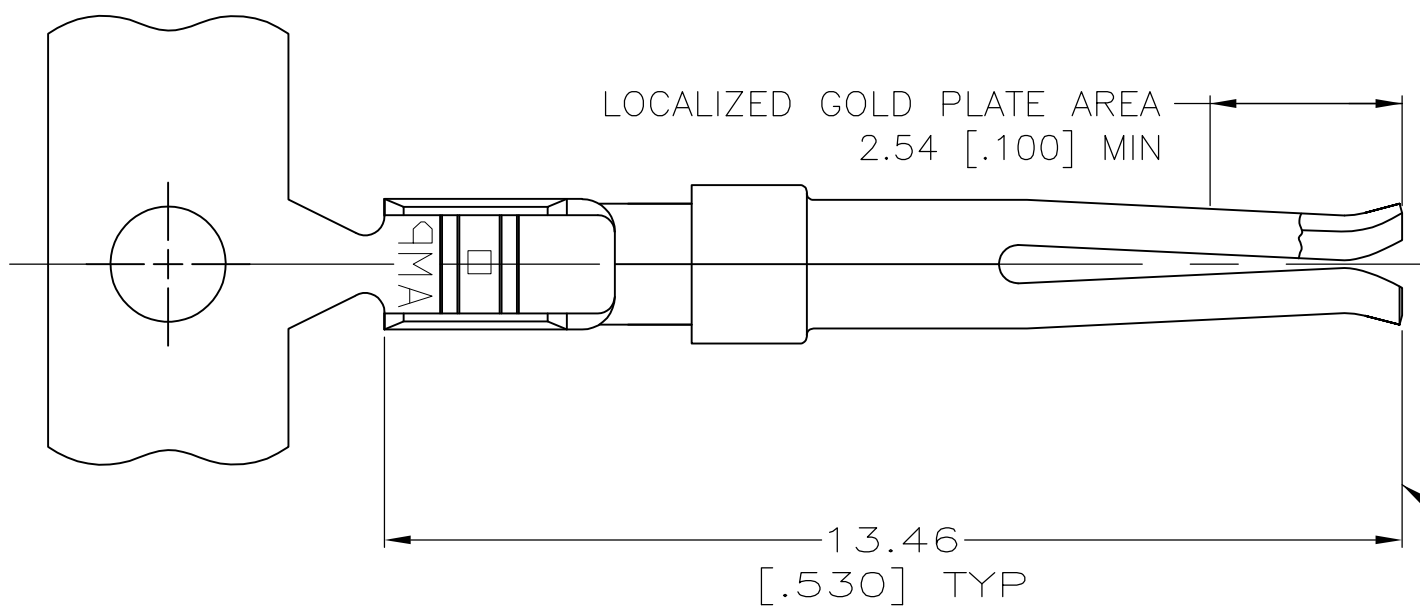

- 1 2.54µm [.000100] MIN TIN OR TIN-LEAD OVER 1.27µm [.000050] MIN NICKEL.
- 2 PLATED WITH 0.76µm [.000030] GOLD ON INSIDE OF LOCALIZED GOLD PLATE AREA, GOLD FLASH ON REMAINDER, ALL OVER 1.27µm [.000050] NICKEL UNDERPLATE.
-OR-
GOLD FLASH OVER PALLADIUM-NICKEL 0.76µm [.000030] TOTAL ON INSIDE OF LOCALIZED GOLD PLATE AREA, GOLD FLASH ON REMAINDER, ALL OVER 1.27µm [.000050] NICKEL UNDERPLATE.
- 3 GOLD PLATING PER MIL-G-45204.
TIN PLATING PER MIL-T-10727.
NICKEL PLATING PER QQ-N-290.
- 4 GOLD FLASH ON INSIDE OF LOCALIZED GOLD PLATE AREA, GOLD FLASH ON REMAINDER, ALL OVER 0.76µm [.000030] NICKEL UNDERPLATE.
- 5 GOLD FLASH FOR A LENGTH OF 2.54 [.100] MIN FROM MATING END, 2.54µm [.000100] MIN TIN PLATED WIRE BARRELS, ALL OVER 0.76µm [.000030] MIN NICKEL.
- 6 0.76µm [.000030] MIN GOLD FOR A LENGTH OF 2.54 [.100] MIN FROM MATING END, 2.54µm [.000100] MIN TIN PLATED WIRE BARRELS, ALL OVER 1.27µm [.000050] MIN NICKEL.

SUPERSEDED BY 205201-5	SMALL PACK	SEE DETAIL C	NO	2	2-205201-8
OBSELETE	STANDARD	-	YES	6	2-205201-5
SUPERSEDED BY 205201-6	STANDARD	-	YES	5	2-205201-2
SUPERSEDED BY 205201-6	STANDARD	-	YES	1	1-205201-4
	STANDARD	SEE DETAIL C	NO	4	205201-7
	STANDARD	-	YES	4	205201-6
	STANDARD	SEE DETAIL C	NO	2	205201-5
	STANDARD	-	YES	2	205201-3
PACKAGING TYPE	LOOSE PIECE	FOR MINI-APPLICATOR	FINISH 3	PART NUMBER	

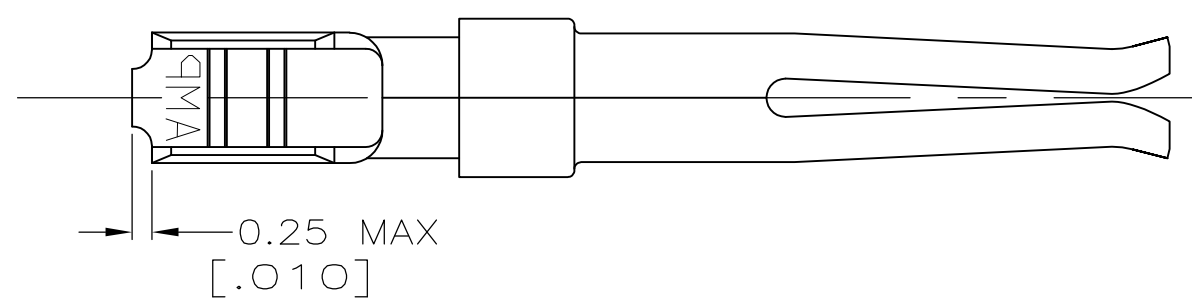

DETAIL C

THIS DRAWING IS A CONTROLLED DOCUMENT.

DIMENSIONS: mm [INCHES]	TOLERANCES UNLESS OTHERWISE SPECIFIED:	DWN M.BINNER 16 FEB 96	
	0 PLC ± -	CHK R.STONE 19 FEB 96	
	1 PLC ± -	APVD L.FIX 19 FEB 96	
	2 PLC ± 0.13 [.005]	NAME	
	3 PLC ± -	PRODUCT SPEC	SOCKET CONTACT, SIZE 20 DF, 20-24 AWG
	4 PLC ± -	APPLICATION SPEC	
	ANGLES ± -		SIZE CAGE CODE DRAWING NO RESTRICTED TO
MATERIAL COPPER ALLOY PER QQ-B-750	FINISH SEE TABLE	WEIGHT -	A2 00779 C=205201
		CUSTOMER DRAWING	SCALE 10:1 SHEET 1 OF 1 REV Z1

单击下面可查看定价，库存，交付和生命周期等信息

[>>TE Connectivity\(泰科\)](#)