

REVISIONS				
P.	LTN	DESCRIPTION	DATE	DMN APVD
L		REVISED PER ECR-14-016951	11FEB2015	J.T. W.H

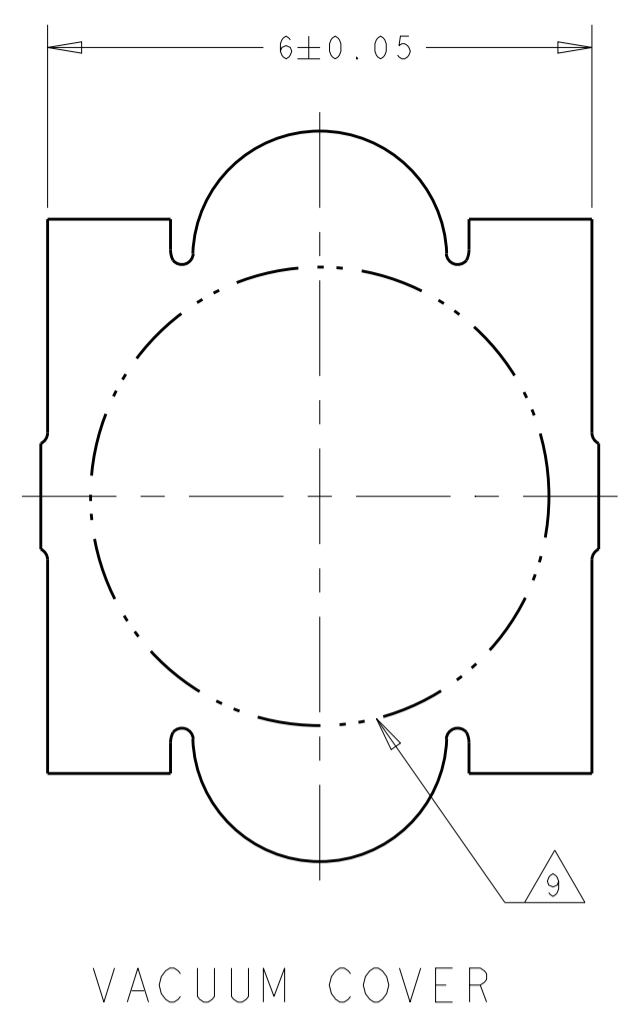

1. HOUSING MATERIAL: HIGH TEMPERATURE THERMOPLASTIC, COLOR: BLACK. CONTACT MATERIAL: PHOSPHOR BRONZE.
2. CONTACT FINISH: NICKEL UNDERPLATE ALL OVER, MATING SURFACES PLATED TO MEET PL1 PERFORMANCE REQUIREMENTS OF INDUSTRY SPECIFICATION EIA-700AAAB, SOLDER TAILS PLATED TIN-LEAD.
3. DATUM LOCATIONS AND BASIC DIMENSIONS TO BE ESTABLISHED BY THE CUSTOMER. CONSULT AMP ENGINEERING WHEN PLACING MULTIPLE CONNECTORS ON A PC BOARD.
4. PACKAGED IN TAPE ON REEL PER EIA-481.
5. 1.4 ± 0.05 DIAMETER HOLE WHEN PLACING BY HAND.
6. SHORTER SOLDER LANDS MAY BE USED PER EIA 700AAAB, HOWEVER 2.4 LENGTH ASSURES OPTIMUM SOLDER FILLET REGARDLESS OF MANUFACTURER OF CONNECTOR.
7. REFERRED TO AS DIM H = 7.3 ± 0.1 IN EIA 700AAAB SPECIFICATION.
8. VACUUM COVER NOT SHOWN IN SOME VIEWS FOR CLARITY.
9. 5.5 MIN DIAMETER TARGET AREA FOR VACUUM PICK-UP.
10. CONTACT FINISH: 0.002 MINIMUM BRIGHT TIN-LEAD (93-7) ON SOLDER AREA. 0.00127 MINIMUM GOLD ON MATING AREA. BOTH OVER 0.00127 MINIMUM NICKEL ON ENTIRE CONTACT.
11. SQUARE AND DIAMOND SHAPED POSTS.
12. ROUND SHAPED POSTS.

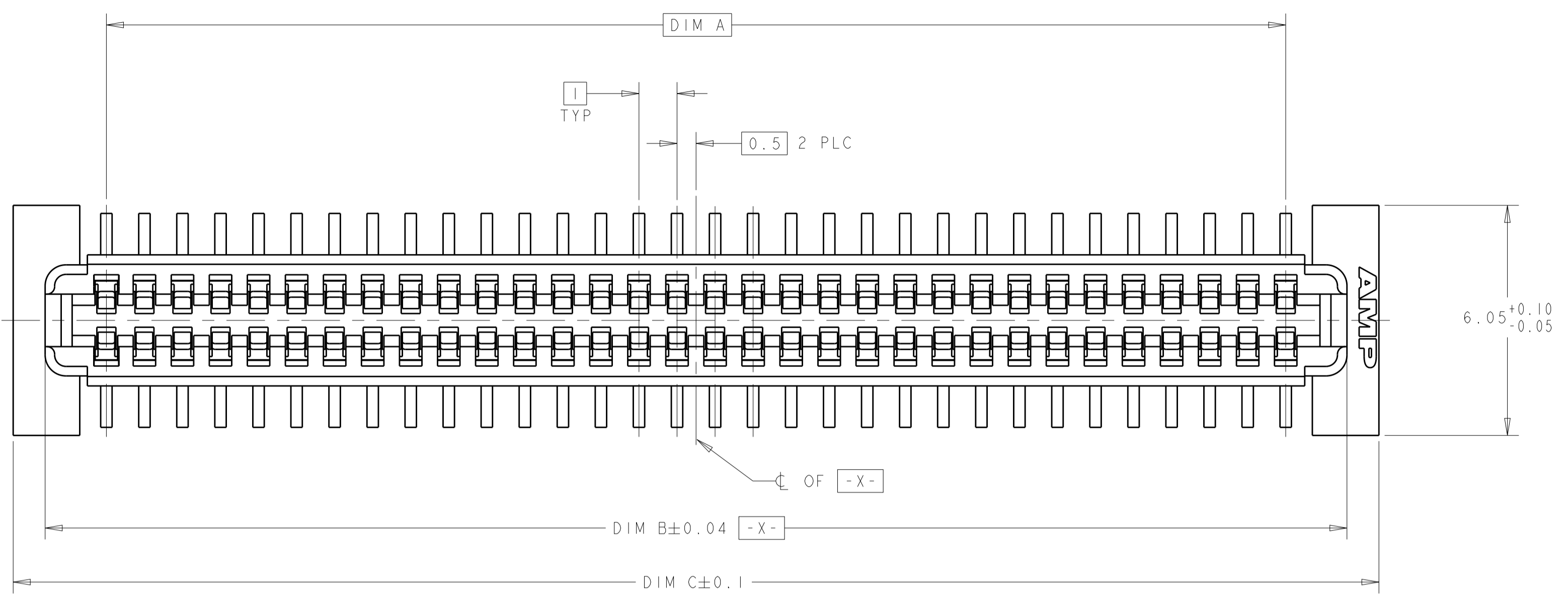
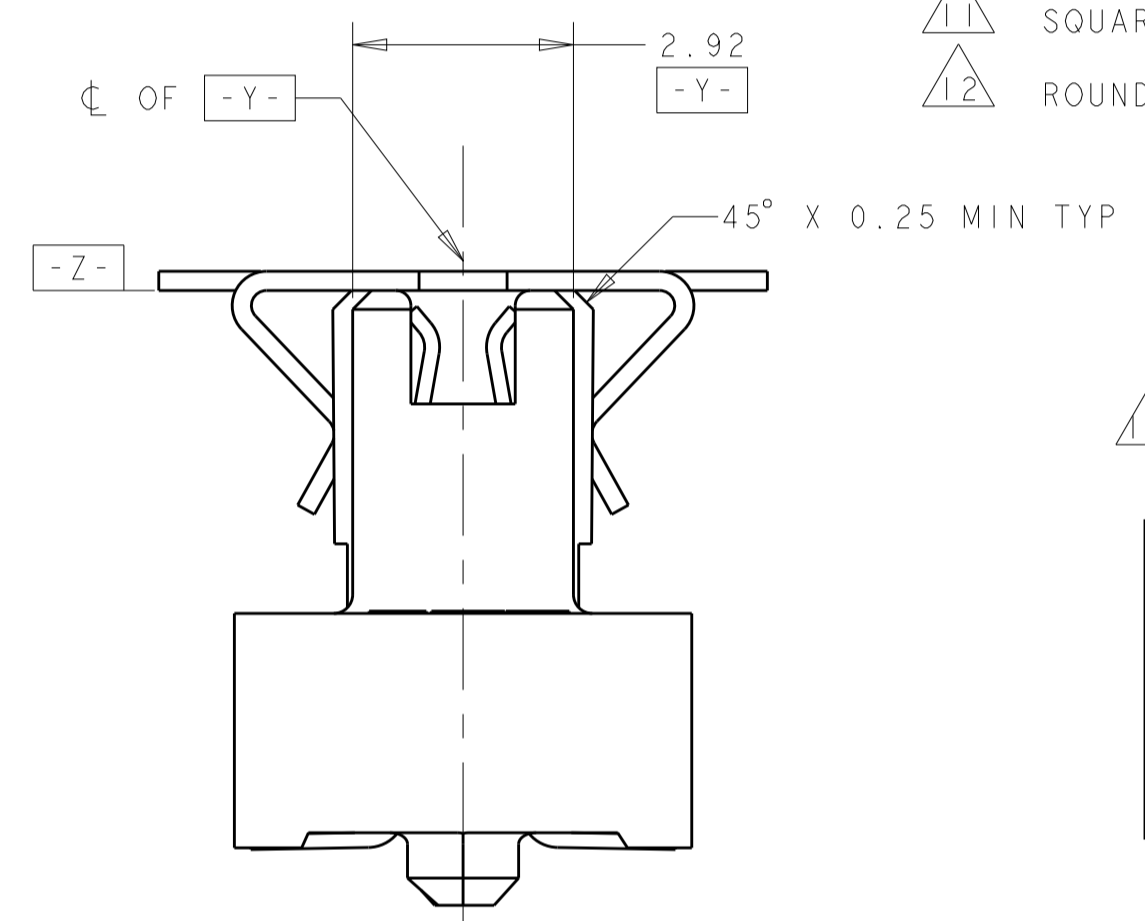
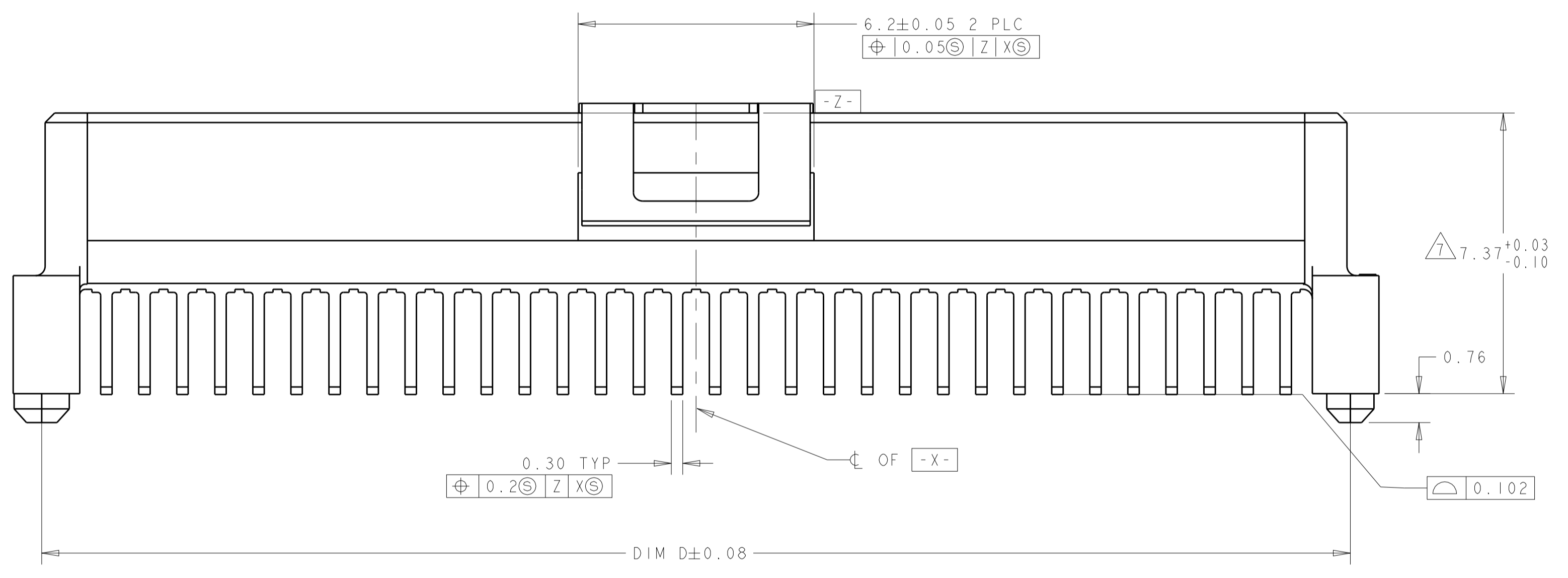

STYLE A POSTS

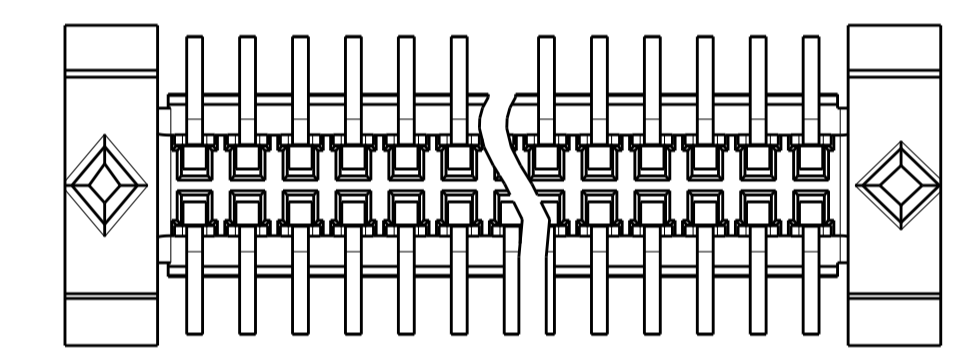

STYLE B POSTS

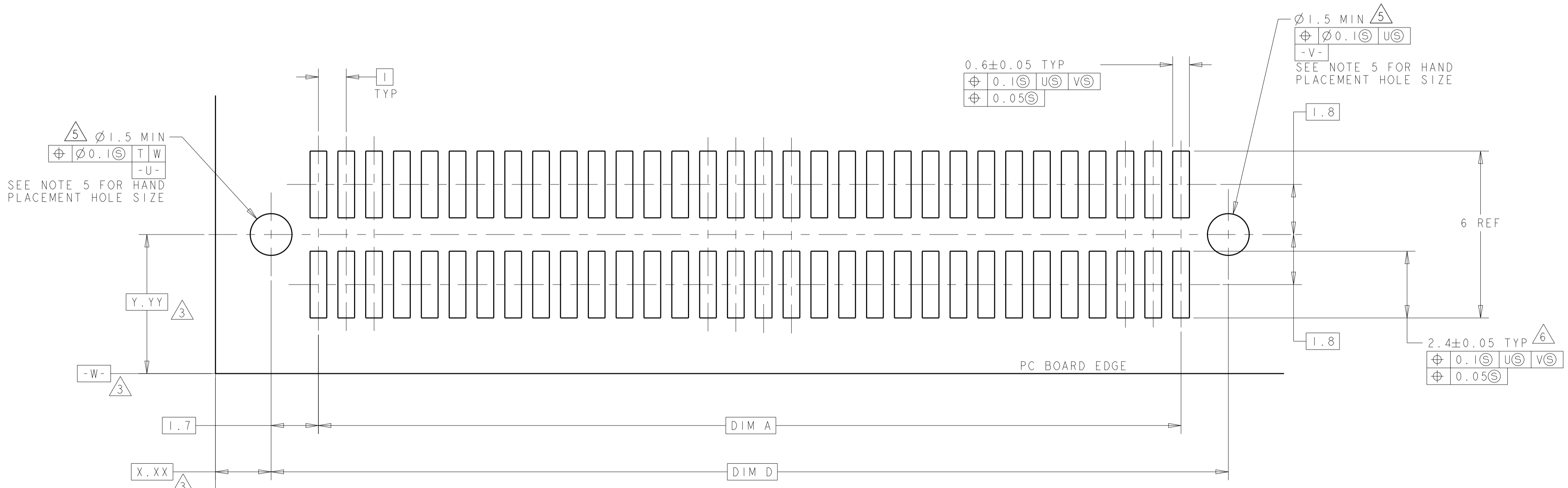
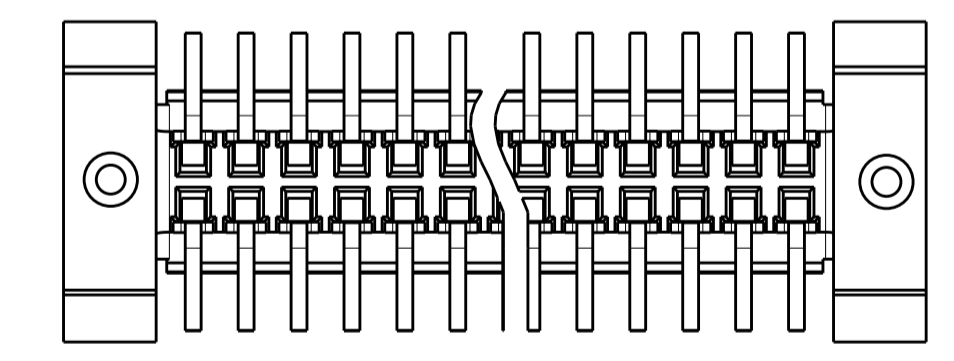

RECOMMENDED PC BOARD LAYOUT

POST STYLE	FINISH	DIM D	DIM C	DIM B	DIM A	STACK HEIGHTS	POS	AMP PART NUMBER
10	10	44.4	45.9	44.22	41	11, 12	84	3-146894-2
12	2	34.4	35.9	34.22	31	11, 12	64	3-146894-1
12	2	44.4	45.9	44.22	41	11, 12	84	2-146894-2
12	2	34.4	35.9	34.22	31	11, 12	64	2-146894-1
11	10	44.4	45.9	44.22	41	11, 12	84	1-146894-2
11	10	34.4	35.9	34.22	31	11, 12	64	1-146894-1
11	2	44.4	45.9	44.22	41	11, 12	84	146894-2
11	2	34.4	35.9	34.22	31	11, 12	64	146894-1

THIS DRAWING IS A CONTROLLED DOCUMENT. DMN DK SCHRUM 28SEP98
CHK CHAD BAKER 28SEP98

TE Connectivity

RECEPTACLE ASSY, W/VACUUM COVER, 1.0mm FH(IEEE 1386) CONNECTOR

SIZE: A1 CAGE CODE: 114-25045 DRAWING NO: 502-1079 APPLICATION SPEC: 114-25045 WEIGHT: -

SCALE: 10:1 SHEET: 1 OF 1 REV: L

单击下面可查看定价，库存，交付和生命周期等信息

[>>TE Connectivity\(泰科\)](#)