

© 1962 BY AMP INCORPORATED. ALL RIGHTS RESERVED. AMP PRODUCTS COVERED BY PATENTS AND/OR PATENTS PENDING. APPROVED PER GOVT CONTRACT NO.

LOCATION FOR AMP-TAB FEMALE CONTACT

LOCATION FOR KEYING PLUG 582501-1 (FOR INTER-CONTACT KEYING)

REVISIONS				
ZONE	LTR	DESCRIPTION	DATE	APPROVED
✓	AA	REVISED PER 0600-3683-95 TA	10-95	J.WARNER
	AB	ECO-08-0220973	PY	11-08 JW

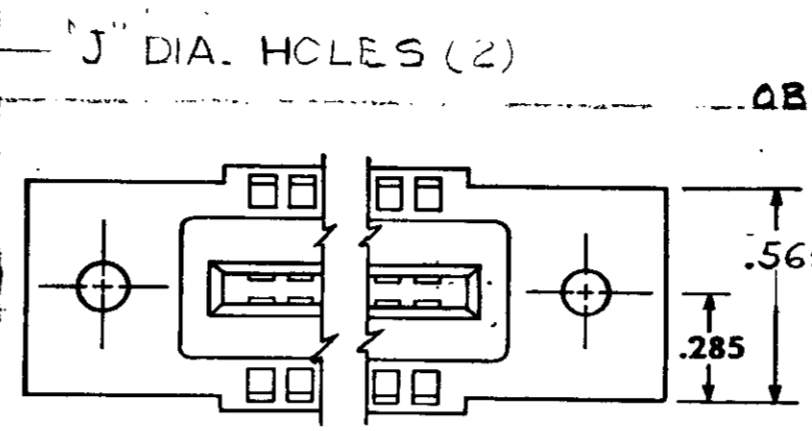
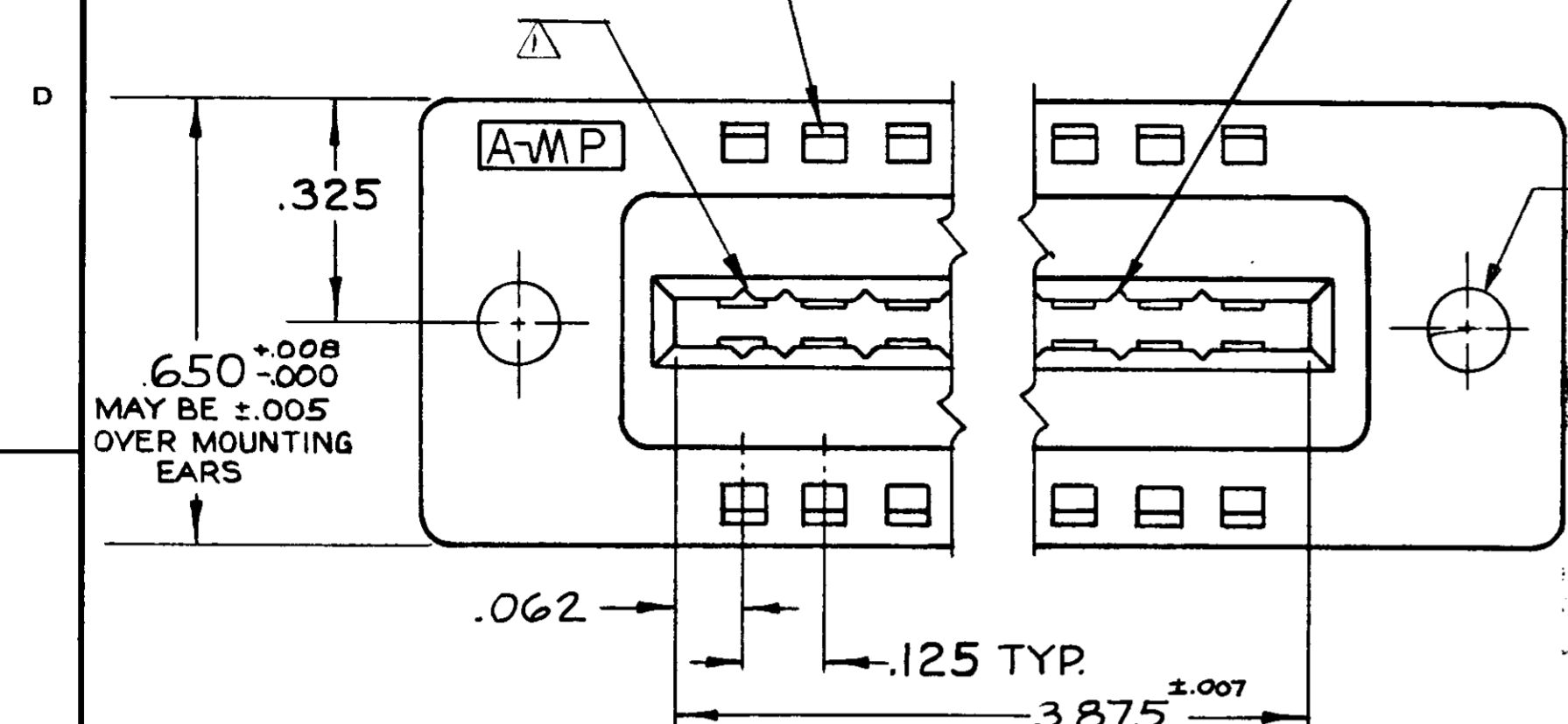

- 582603-1 1. AS SHOWN. "J" DIA HOLES = .128
- ~~582603-2~~ 1. SAME AS -1 EXCEPT;
2. "J" DIA HOLES = .150
- ~~582603-3~~ 1. REFER TO DWG. NO. 582603-3.
- ~~582603-4~~ 1. SAME AS -1 EXCEPT;
2. CUSTOMER PART NO STAMPED ON BLOCK IN PLACE OF AMP PART NO.
- 582603-5 1. SAME AS -1 EXCEPT; SPECIAL PART.
- 582603-6 1. REFER TO DWG. NO 582603-6.
- ~~582603-7~~ 1. SAME AS -1 EXCEPT;
2. WITH FLOATING BUSHING (SEE DETAIL).
- 582603-8 1. SAME AS -2 EXCEPT;
2. FEMALE CONTACT WITH SPECIAL GOLD PLATING.

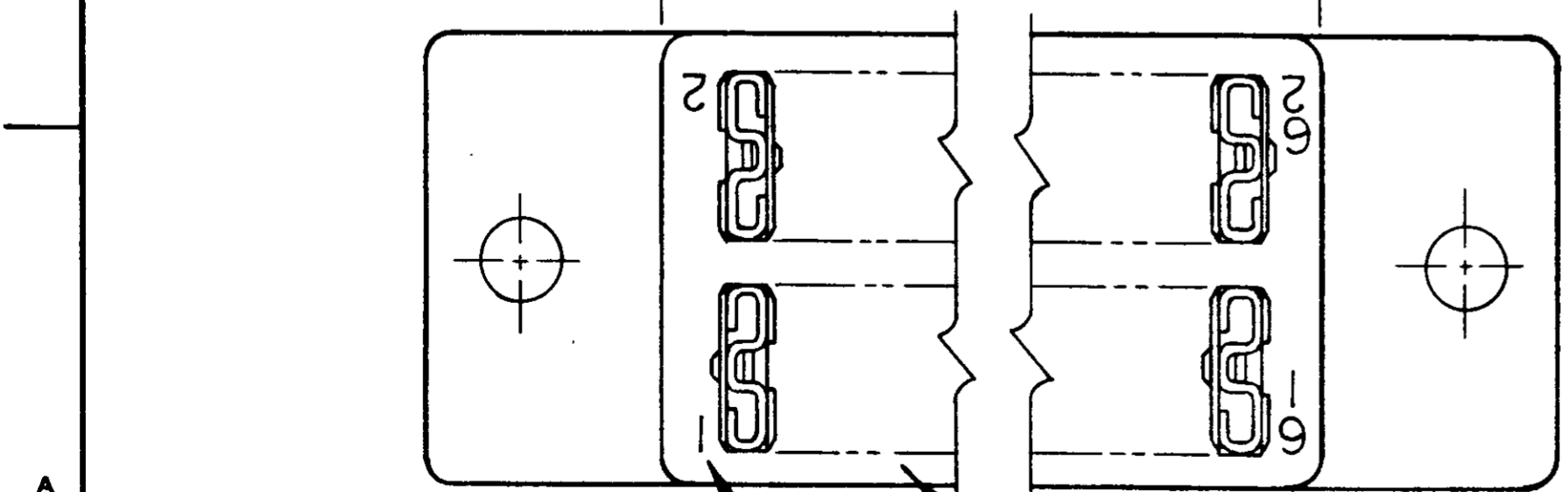
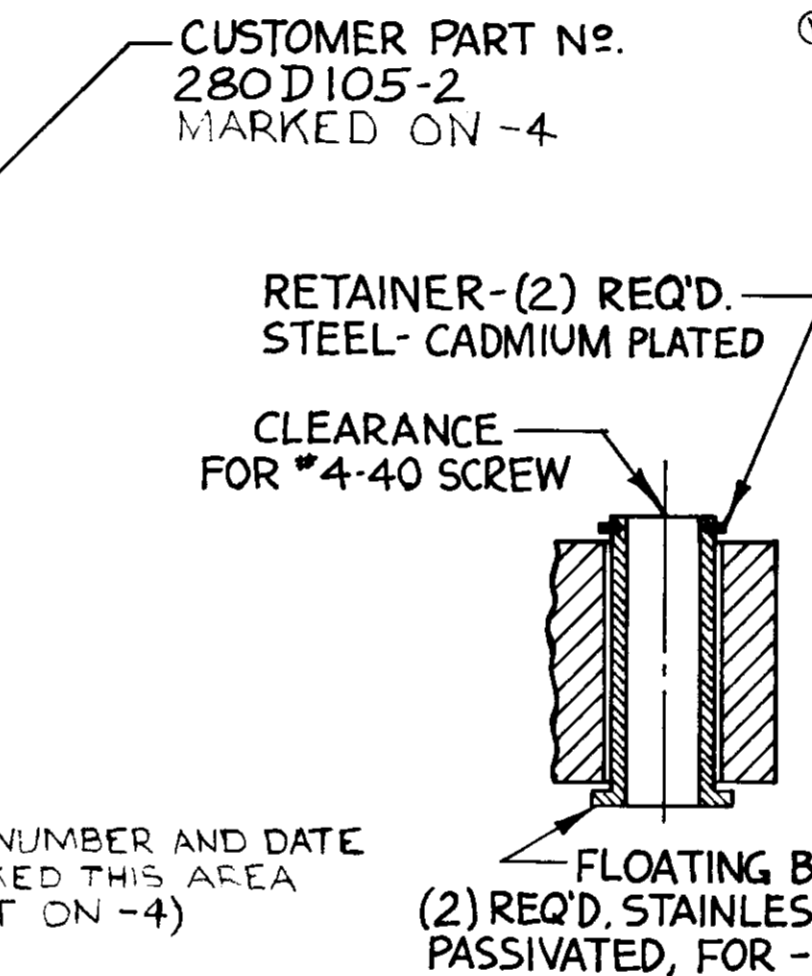
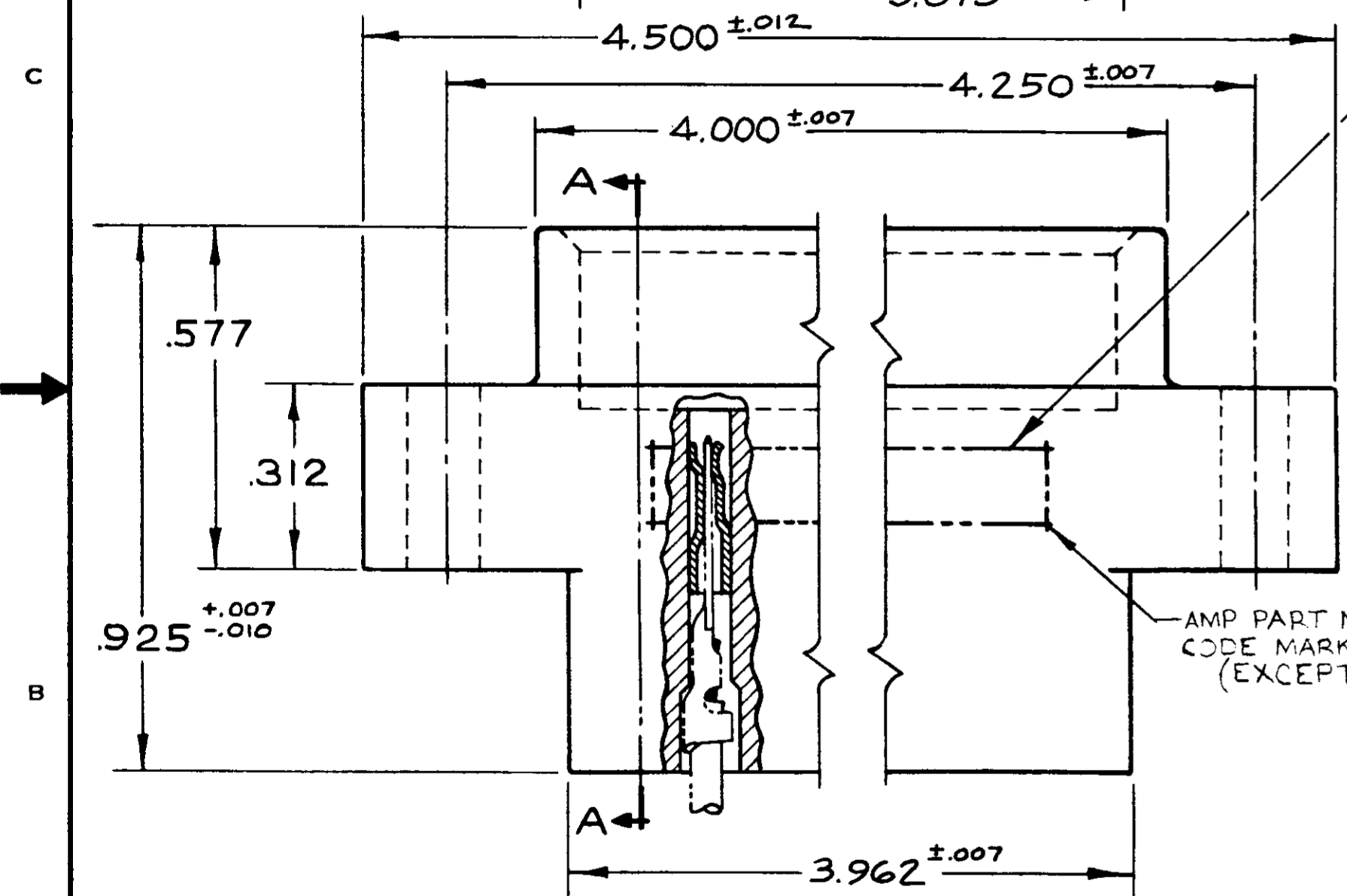

▲ GROOVES FOR "ON CONTACT KEYING" AMP'S OPTION DEPENDING ON METHOD OF MANUFACTURE. FOR "ON CONTACT" KEYING USE KEYING PLUG P/N 583487-1. (MUST BE ORDERED SEPARATELY.)
 ▲ MOUNTING EAR CONFIGURATION AMP'S OPTION DEPENDS ON METHOD OF MANUFACTURE.

UNLESS OTHERWISE SPECIFIED DIMENSIONS ARE IN INCHES TOLERANCES ON FRACTIONS DECIMALS ANGLES ± .005 ± .005 ±		CONTRACT NO.		AMP INCORPORATED HARRISBURG, PENNSYLVANIA	
SEE CALLOUT		DR <i>f. Smith</i>	DATE 4-26-67	NAME	
HEAT TREAT		CHK <i>S. Heide</i>	DATE 5/2/67	31 POSITION AMP-TAB CONNECTOR .125 CENTERS QUAD	
FINISH		APPD <i>[Signature]</i>	DATE	SIZE C	CODE IDENT NO 00779
SEE CALLOUT		DSGN ENGR	DATE	NUMBER 582603	REV AB
		DSGN APPD	DATE	SCALE 4-	SHEET
		OTHER APPD	DATE		

AMP INFO
 LOC PRINT BY
 DF FO

单击下面可查看定价，库存，交付和生命周期等信息

[>>TE Connectivity\(泰科\)](#)