

THIS DRAWING IS UNPUBLISHED.		RELEASED FOR PUBLICATION	
© COPYRIGHT - By -		ALL RIGHTS RESERVED.	
PROJECT	PRJ-14-000004825		
PART NO.	X-2314103-X		
DESCRIPTION	M12 CRIMP CONTACT SOCKET 1mm Au 0.8μ AWG20/AWG22		
CUSTOMER	GENERAL MARKET		

REVISIONS					
P	LTR	DESCRIPTION	DATE	DWN	APVD
	A2	REVISED PER ECR-17-013331	11SEP2017	GK	SE

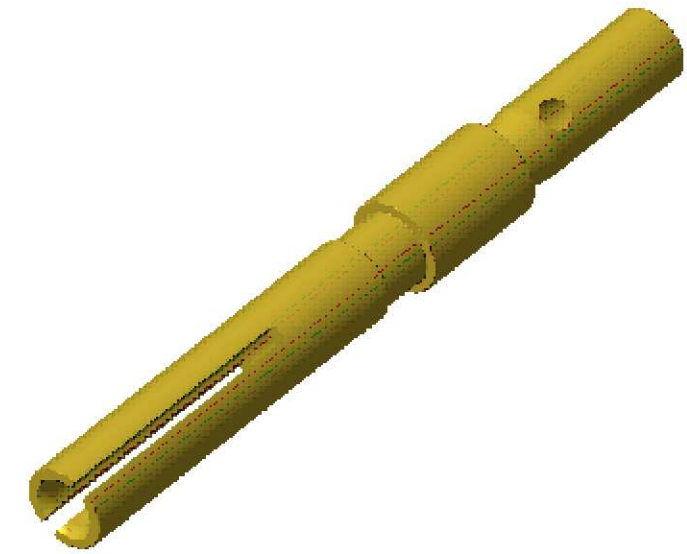
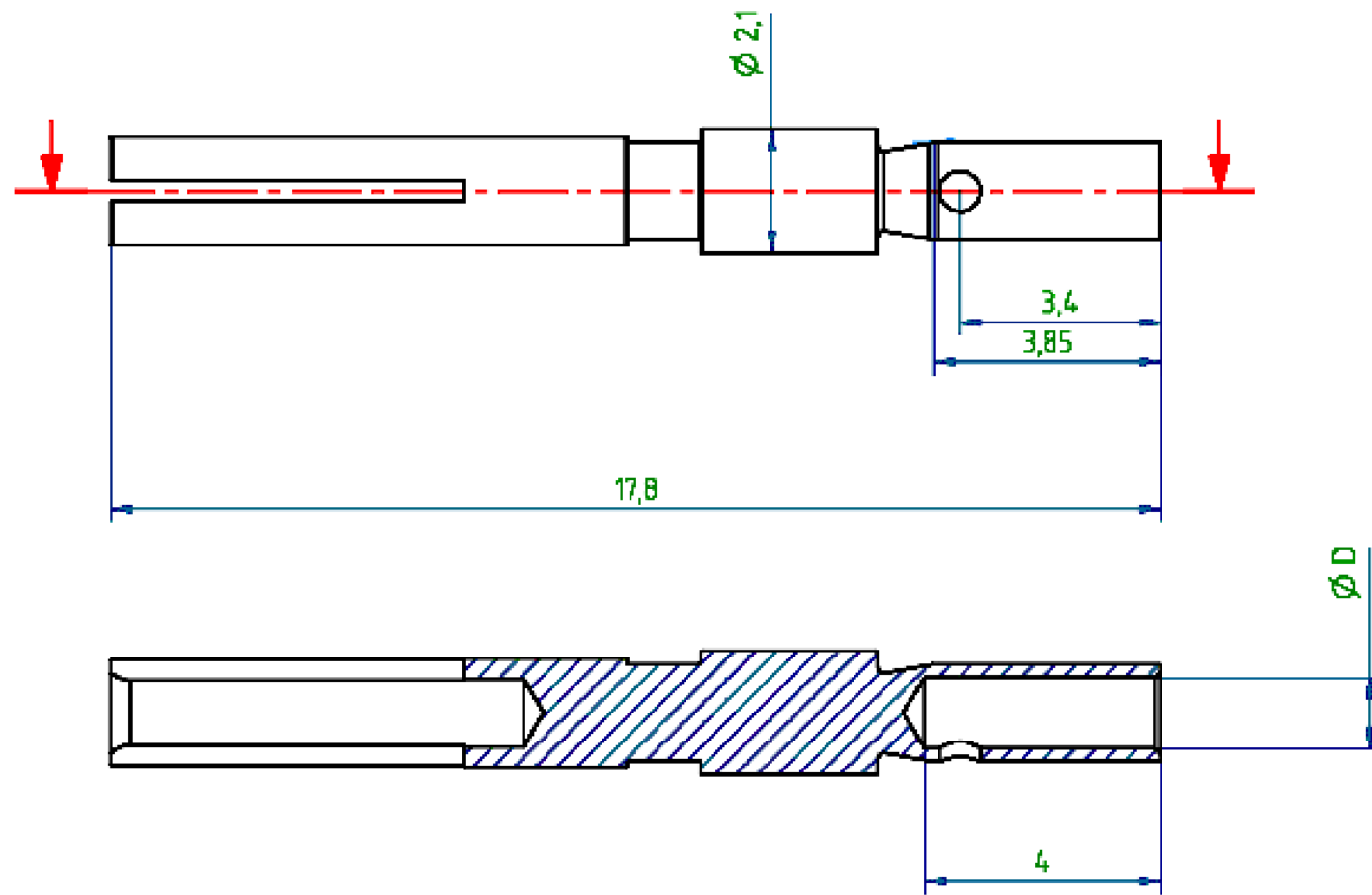

ISO VIEW

NOTES:
 1. APPLICATION TOOLING TO BE USED
 601967-1 (STANDARD) OR
 601966-1 (COMPACT).

SL. NO	PART NO.	PART NAME	ØD	MATERIAL	SURFACE TREATMENT	REMARKS
3	1-2314103-4	M12 CRIMP CONTACT SOCKET 1mm AWG26 Au 0.8μ	0.6			-
2	1-2314103-2	M12 CRIMP CONTACT SOCKET 1mm AWG22/24 Au 0.8μ	0.9	BRASS	1.5-2.5μm Ni/0.8μm Au	-
1	1-2314103-1	M12 CRIMP CONTACT SOCKET 1mm AWG20 Au 0.8μ	1.1			-

THIS DRAWING IS A CONTROLLED DOCUMENT.		DWN KIRAN K 06DEC2016	 TE Connectivity M12 CRIMP CONTACT SOCKET 1mm Au 0.8 MICRON AWG20/AWG22			
DIMENSIONS: mm		CHK KIRAN K 06DEC2016				
TOLERANCES UNLESS OTHERWISE SPECIFIED: DIN ISO 2768 m		APVD S EGBERT 06DEC2016				
0 PLC ± - 1 PLC ± - 2 PLC ± - 3 PLC ± - 4 PLC ± - ANGLES ± -		NAME 108-156001				
MATERIAL		PRODUCT SPEC 114-156002	SIZE A3	CAGE CODE 00779	DRAWING NO C-2314103	RESTRICTED TO
FINISH		WEIGHT	CUSTOMER DRAWING		SCALE NTS	SHEET 1 OF 1
					REV A2	

单击下面可查看定价，库存，交付和生命周期等信息

[>>TE Connectivity\(泰科\)](#)