

DRAWING MADE IN THIRD ANGLE PROJECTION
 THIS DRAWING IS UNPUBLISHED. RELEASED FOR PUBLICATION ,19 .
 © COPYRIGHT 19 BY AMP INCORPORATED. ALL INTERNATIONAL RIGHTS RESERVED.

LOC		DIST		REVISIONS				DATE	APPD
ZONE	LTR	DESCRIPTION	DATE	APPD					
G	14			G	REV & REDRAWN PER 0720-0061-93	4-19-93	APP DAP		

METRIC
 DIMENSIONS LISTED IN mm [INCHES]

AMP WIRE RANGE	UL E13288 Listed
16-14 AWG SOLID OR STRANDED	NOT APPLICABLE
SR LR7189 Certified	MILITARY P/N AND CLASS
NOT APPLICABLE	NOT APPLICABLE

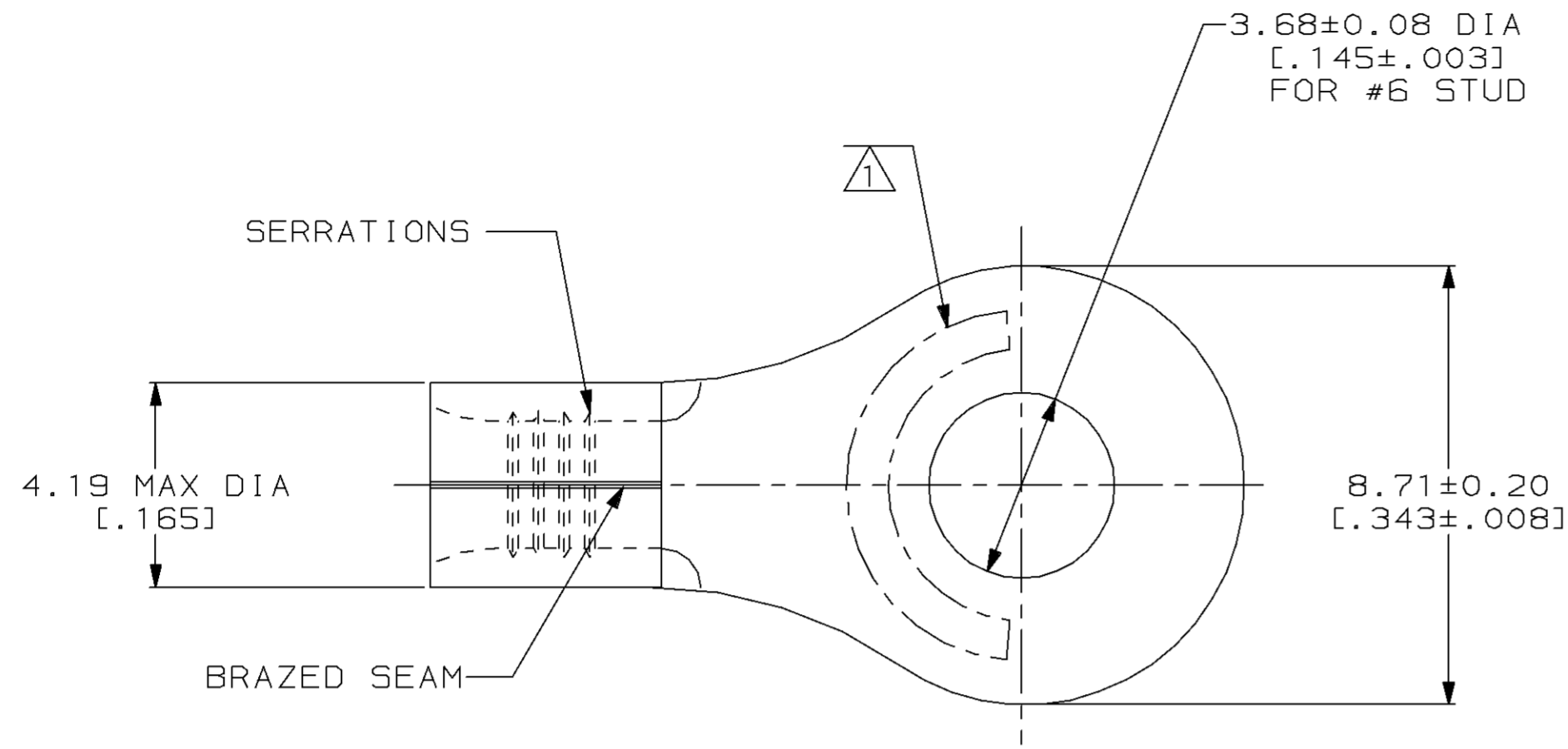

① STAMP AMP 16-14* APPROX AS SHOWN

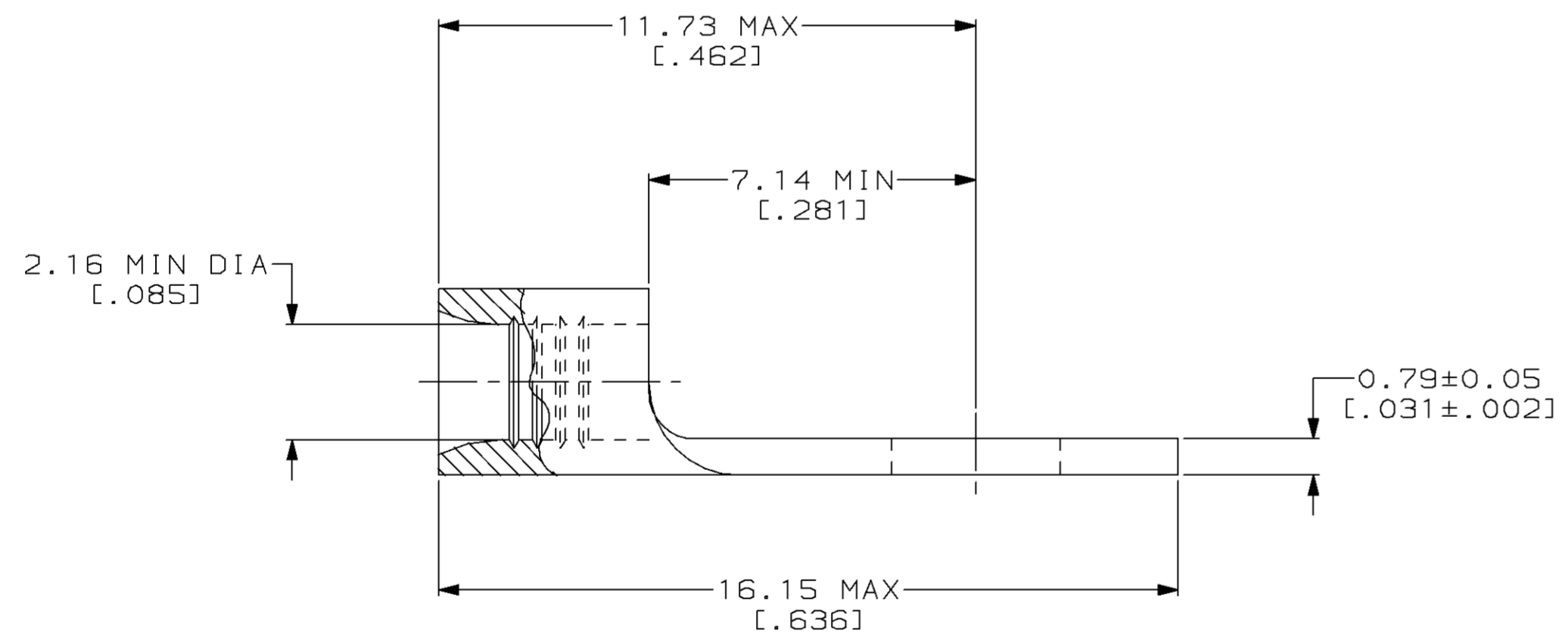

AMP INCORPORATED CUSTOMER SERVICE SYSTEMS		MAX RECOMMENDED OPERATING TEMPERATURE: 343°C MAX	DO NOT SCALE PRINT. UNLESS SPECIFIED DIMENSIONS IN mm [INCHES] TOLERANCES ON: 2 PLC DEC ± - 3 PLC DEC ± - ANGLES ± -	DR 4-19-93 TA BRINKMAN	AMP AMP Incorporated Harrisburg, PA 17105-3608		
FOR ADDITIONAL PRODUCT INFORMATION OR COPIES OF DRAWINGS AND TECHNICAL DOCUMENTS	PRODUCT INFORMATION CENTER 1-800-522-6752	VOLTAGE RATING: NOT APPLICABLE	MATERIAL COPPER PER ASTM B-152 ANNEALED	CHK 4-19-93 DA PATTERSON	NAME TERMINAL, RING TONGUE, HEAT RESISTANT, STRATO-THERM™		
FOR APPLICATION TOOLING INFORMATION	TOOLING ASSISTANCE CENTER 1-800-722-1111	WIRE CROSS SECTIONAL AREA RANGE: 1.04-2.62mm² [2,050-5,180] CIR MILS SOLID OR STRANDED	FINISH NICKEL PLATE 0.00762 [.000300] MIN THK PER QQ-N-290	APPD 4-19-93 DE MILLER	APPD 4-19-93 JL MECKLEY	PRODUCT SPEC -	SIZE CAGE CODE DRAWING NO
FOR ORDER ENTRY	1-800-526-5142	THIS DRAWING IS A CONTROLLED DOCUMENT FOR AMP INCORPORATED. IT IS SUBJECT TO CHANGE AND THE CONTROLLING ENGINEERING ORGANIZATION SHOULD BE CONTACTED FOR THE LATEST REVISION.		APPLICATION SPEC -	WEIGHT -	SCALE 8:1	③ 00779 C=322693
							SHEET 1 OF 1

单击下面可查看定价，库存，交付和生命周期等信息

[>>TE Connectivity\(泰科\)](#)