

.XXX = in
XX.X = mm

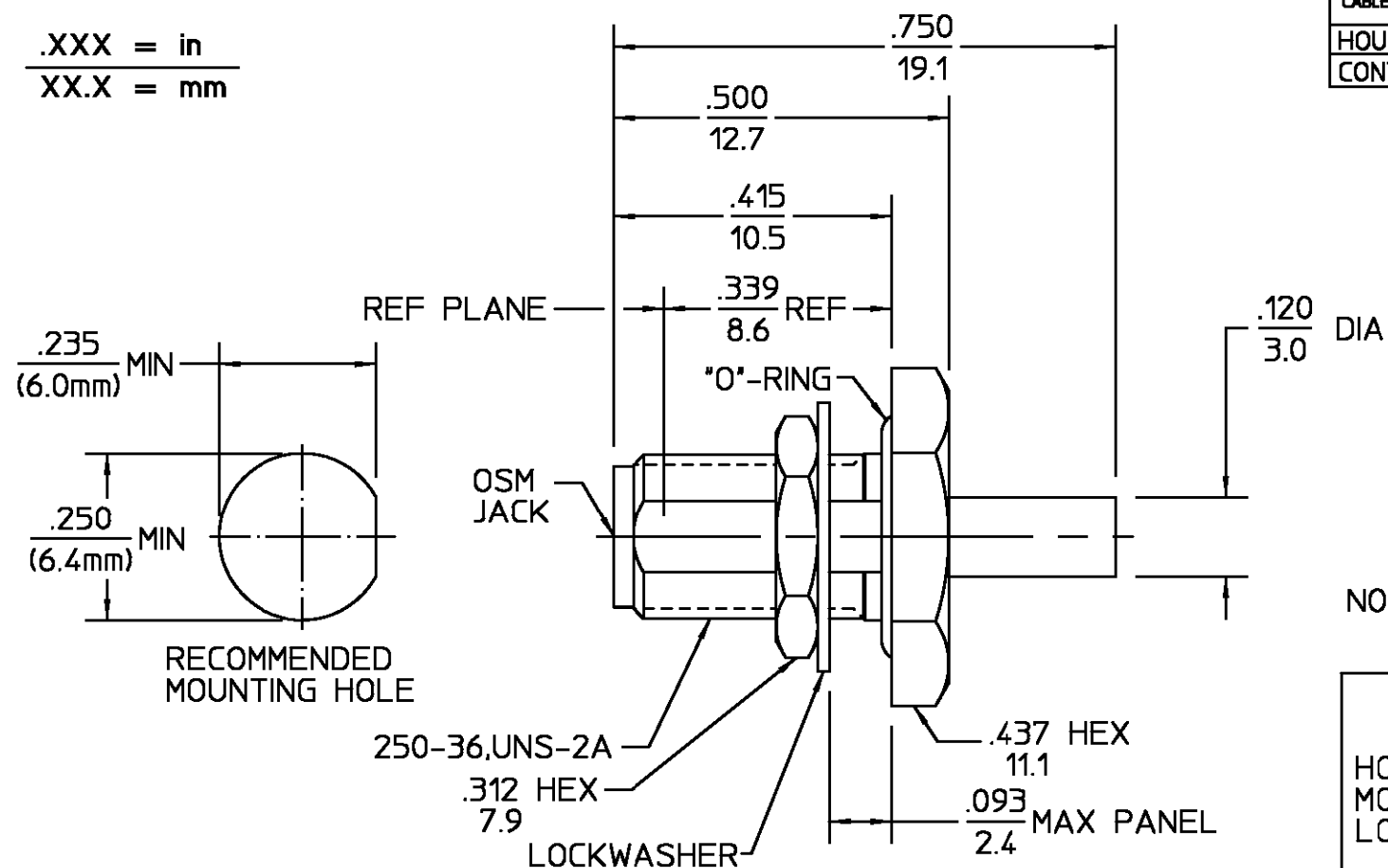

CABLE ENTRY DIAMETER MINIMUM		REVISIONS			
HOUSING	CONTACT	REV	DESCRIPTION	DATE	APPROVED
.089	.021	010	RELEASED	5/1/95	<i>RAC</i>

NOTE: DESIGN FOR USE WITH .085 DIA SEMI-RIGID CABLE

COMPONENT	MATERIAL	FINISH
HOUSING MOUNTING NUT LOCKWASHER	STAINLESS STEEL PER ASTM-A484 AND ASTM-A582, TYPE 303	GOLD PLATE PER MIL-G-45204
DIELECTRIC	TFE FLUOROCARBON PER ASTM-D-1457 AND MIL- P-19468	N/A
CENTER CONTACT	BERYLLIUM COPPER PER ASTM B 196, ALLOY C17300, CONDITION H	GOLD PLATE PER MIL-G-45204
GASKET	SILICONE RUBBER PER ZZ-R-765	N/A

ELECTRICAL	MECHANICAL	ENVIRONMENTAL
Nominal Impedance (Ohms) <u>50</u>	Interface Dimensions MIL-STD-348, Fig. <u>310.2</u>	Temperature Rating <u>-65°C to +105°C</u>
Frequency Range (GHz) DC to <u>18</u>	Recommended Mating Torque <u>7-10 INBS</u>	Vibration MIL-STD-202, Method 204, Condition D
Volt Rating (VRMS MAX) @ Sea Level <u>335</u>	Mating Characteristics: Insertion (MAX Lbs) <u>3.0</u>	Shock MIL-STD-202, Method 213, Condition <u>I</u>
VSWR <u>1.07 +.01f(GHz)</u>	Withdrawal (MIN Oz) <u>1.0</u>	Thermal Shock MIL-STD-202, Method 107, Condition <u>B</u>
Insertion Loss (dB MAX) <u>.03 √f(GHz)</u>	Force to Engage and Disengage (In/Lbs MAX) <u>2.0</u>	Except High Temp <u>+115°C</u>
RF Leakage (dB MIN) <u>-90 @ 2 to 3 (GHz)</u>	Center Contact Captivation Axial (Lbs) <u>6.0</u>	Moisture Resistance MIL-STD-202, Method 106, Insulation Resistance Shall Be 200 Megohms min within 5 Minutes After Removal From Humidity
Corona, 70,000 Ft (VRMS MIN) <u>250</u>	Radial (In/Oz) <u>N/A</u>	Corrosion - MIL-STD-202, Method 101, Condition B, 5% salt spray
Dielectric Withstanding Voltage (VRMS MIN) @ Sea Level <u>1000</u>	Cable Retention Axial Force (Lbs) <u>30</u>	
Contact Resistance (Milliohms MAX) Center Contact <u>3.0</u>	Torque (In/Oz) <u>16</u>	
Outer Contact <u>2.0</u>	Weight (Grams) <u>3.5</u>	
Cable to Housing <u>0.5</u>		
RF High Potential @ Sea Level (VRMS MIN @ 5 MHz) <u>670</u>		
LR.(Megohms MIN) <u>10,000</u>		

UNLESS OTHERWISE SPECIFIED DIMENSIONS ARE IN INCHES TOLERANCE ON FRAC. DEC. ANGLES ± 1/64 ±.005 ± 1°	DRAWN BY <i>RAC</i> DATE 5/1/95 CHECKED BY <i>RAC</i> APPD BY <i>RAC</i> 5/1/95	AMP Incorporated 140 Fourth Avenue Waltham, MA 02451-7599	
These drawings and specifications are the property of Omni Spectra Incorporated and shall not be reproduced or copied or used in whole or in part as the basis for the manufacture or sale of item(s) without written permission.	USE ASS'Y PROCEDURE 408-04856 NO. AP. (20-702)	TITLE OSM STRAIGHT BULKHEAD FEEDTHROUGH CABLE JACK DIRECT SOLDER ATTACHMENT	
	SIZE B	CODE IDENT NO. 26805	REV 010
	SCALE 4:1	2004-7585-00	SHEET 1 OF 1

CUSTOMER DRAWING

AMP PART # 1051003-1
SHEET 1 OF 1 REV A

单击下面可查看定价，库存，交付和生命周期等信息

[>>TE Connectivity\(泰科\)](#)