

THIS DRAWING IS UNPUBLISHED. RELEASED FOR PUBLICATION  
 © COPYRIGHT BY TYCO ELECTRONICS CORPORATION. ALL INTERNATIONAL RIGHTS RESERVED.

LOC		DIST		REVISIONS			
P	LTR	DESCRIPTION	DATE	DWN	APVD		
B		REVISED EPR ECO-11-002638	10FEB11	HMR	JO		

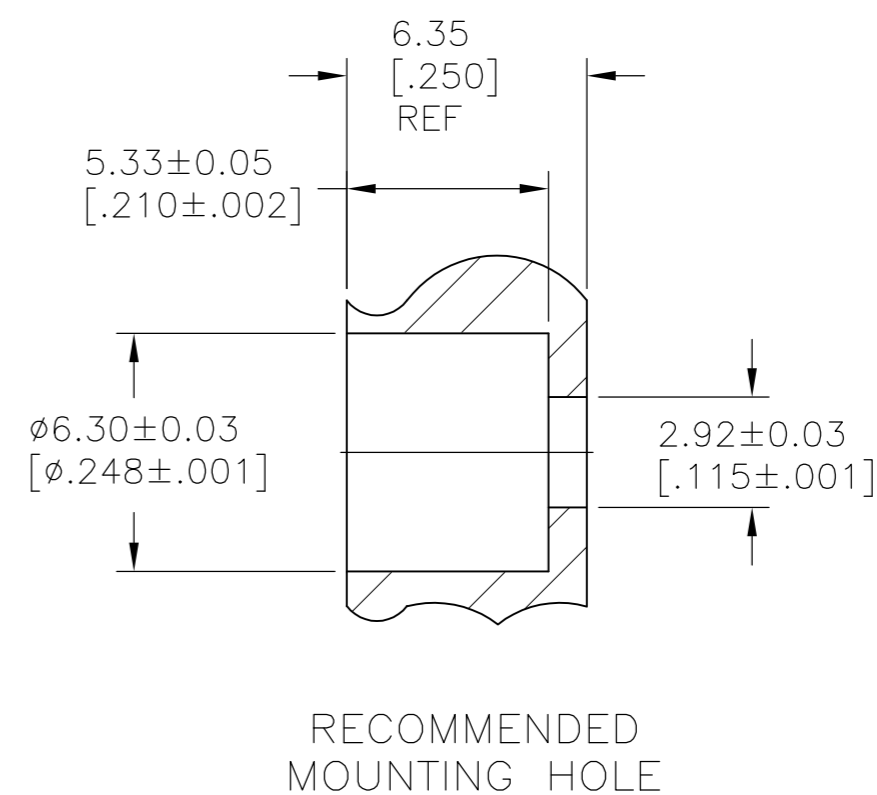
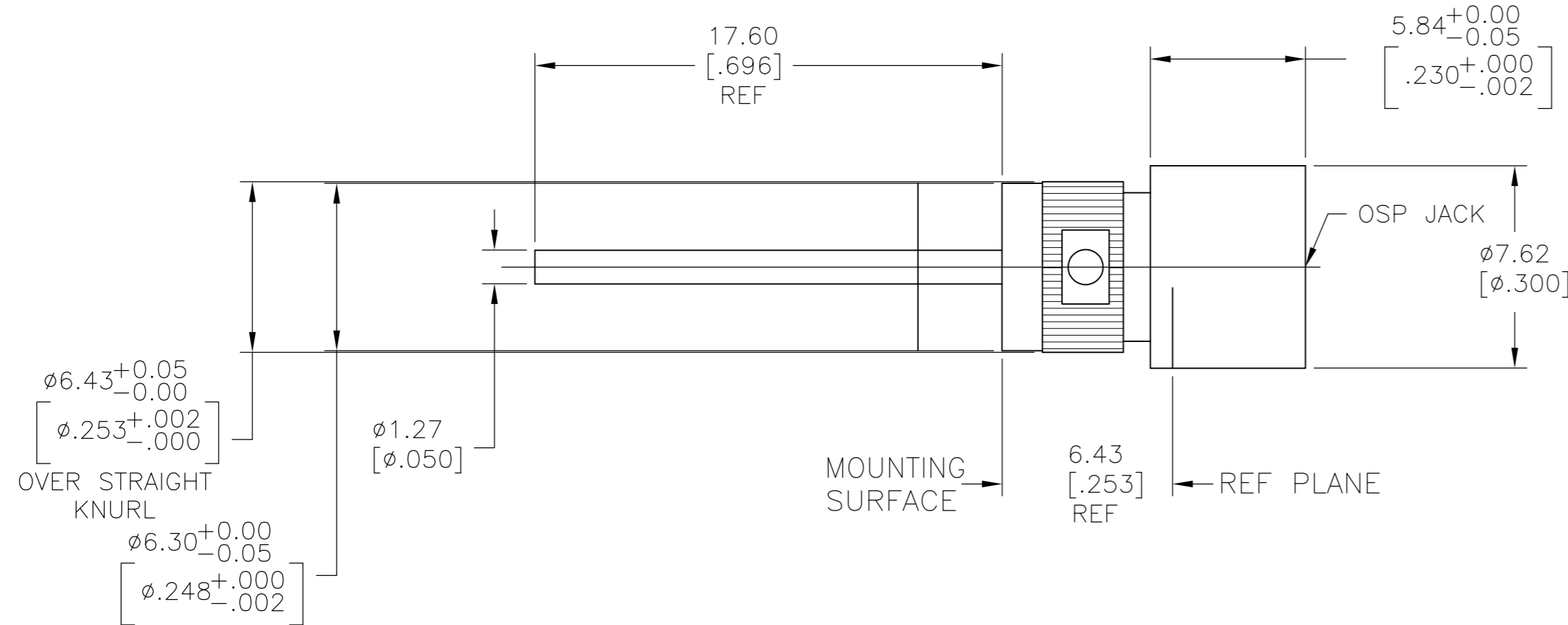

ELECTRICAL	MECHANICAL	ENVIRONMENTAL
Nominal Impedance (Ohms) <u>50</u>	Interface Dimensions Per MIL-STD-348A <u>FIG. 321-2</u>	TEMPERATURE RATING <u>-65° TO +125°C</u>
Frequency Range (GHz) DC to <u>18</u>	Mating Characteristics:	Vibration MIL-STD-202, Method <u>204, Condition D</u>
Volt Rating (VRMS MAX) @ Sea Level <u>500</u>	Insertion (MAX Lbs) <u>3</u>	Shock MIL-STD-202, Method 213, <u>Condition I</u>
VSWR <u>1.05+0.005f(GHz)</u>	Withdrawal (MIN Oz) <u>1</u>	Thermal Shock MIL-STD-202, <u>Method 107, Condition B</u>
Insertion Loss (dB MAX) <u>.03x √f(GHz)</u>	Force to Engage (Lbs MAX) <u>3</u> & Disengage (Lbs MAX) <u>1.5</u>	Moisture Resistance MIL-STD-202, <u>Method 106</u>
RF Leakage (dB MIN) (Interface Only, Fully Mated) <u>-(90-f(GHz))</u>	Center Contact Captivation Axial (Lbs) <u>6</u>	Corrosion - MIL-STD-202, Method <u>101, Condition B</u>
Corona, 70,000 Ft (VRMS MIN) <u>335</u>	Cable Retention Axial Force (Lbs MIN) <u>N/A</u>	
Dielectric Withstanding Voltage (VRMS MIN) @ Sea Level <u>1000</u>	Torque (In-Oz MIN) <u>N/A</u>	
Contact Resistance (Milliohms MAX) Center Contact <u>2.0</u>	Weight (Grams) <u>TBD</u>	
Outer Contact <u>2.0</u>		
Cable to Housing <u>N/A</u>		
RF High Potential @ Sea Level (VRMS MIN @ 5 MHz) <u>1000</u>		
I.R.(Megohms MIN) <u>5000</u>		

.XXX = in  
XX.X = mm

COMPONENT	MATERIAL	FINISH
HOUSING	STAINLESS STEEL PER ASTM-A484 AND ASTM-A582, TYPE 303	ASSIVATE PER QQ-P-35
DIELECTRIC	TFE FLUOROCARBON PER ASTM-D-1457	N/A
CENTER CONTACT	BERYLLIUM COPPER PER ASTM-B-196 OR ASTM-B-197, ALLOY C17300, CONDITION H	GOLD PLATE PER MIL-G-45204
CONTACT RING	BERYLLIUM COPPER PER ASTM-B-194, ALLOY C17200, CONDITION H	GOLD PLATE PER MIL-G-45204

THIS DRAWING IS A CONTROLLED DOCUMENT.		DWN RAGHAVENDRA 10FEB11	Tyco Electronics Corporation Harrisburg, PA 17105-3608	
DIMENSIONS: mm [INCHES]		CHK ORNER JEFFREY 10FEB11	NAME OSP PANEL FEEDTHRU JACK RECEPTACLE STRAIGHT TERMINAL	
TOLERANCES UNLESS OTHERWISE SPECIFIED:		APVD ORNER JEFFREY 10FEB11	SIZE A2	CAGE CODE 00779
0 PLC ± -		PRODUCT SPEC	DRAWING NO C=1081368	RESTRICTED TO
1 PLC ± -		APPLICATION SPEC	SCALE 5:1	SHEET 1 of 1
2 PLC ± -		WEIGHT	REV B	
3 PLC ± 0.13[.005]		CUSTOMER DRAWING		
4 PLC ± - ± 1°				
MATERIAL				
FINISH				

单击下面可查看定价，库存，交付和生命周期等信息

[>>TE Connectivity\(泰科\)](#)