

THIS DRAWING IS UNPUBLISHED. RELEASED FOR PUBLICATION 20
© COPYRIGHT 20 BY TYCO ELECTRONICS CORPORATION. ALL RIGHTS RESERVED.

LOC	DIST	REVISIONS					
GP	00	P	LTR	DESCRIPTION	DATE	DWN	APVD
		A		INITIAL RELEASE	16OCT2006	GIP	DO
		B		REVISED PER ECO-07-004109	21FEB2007	GIP	DO

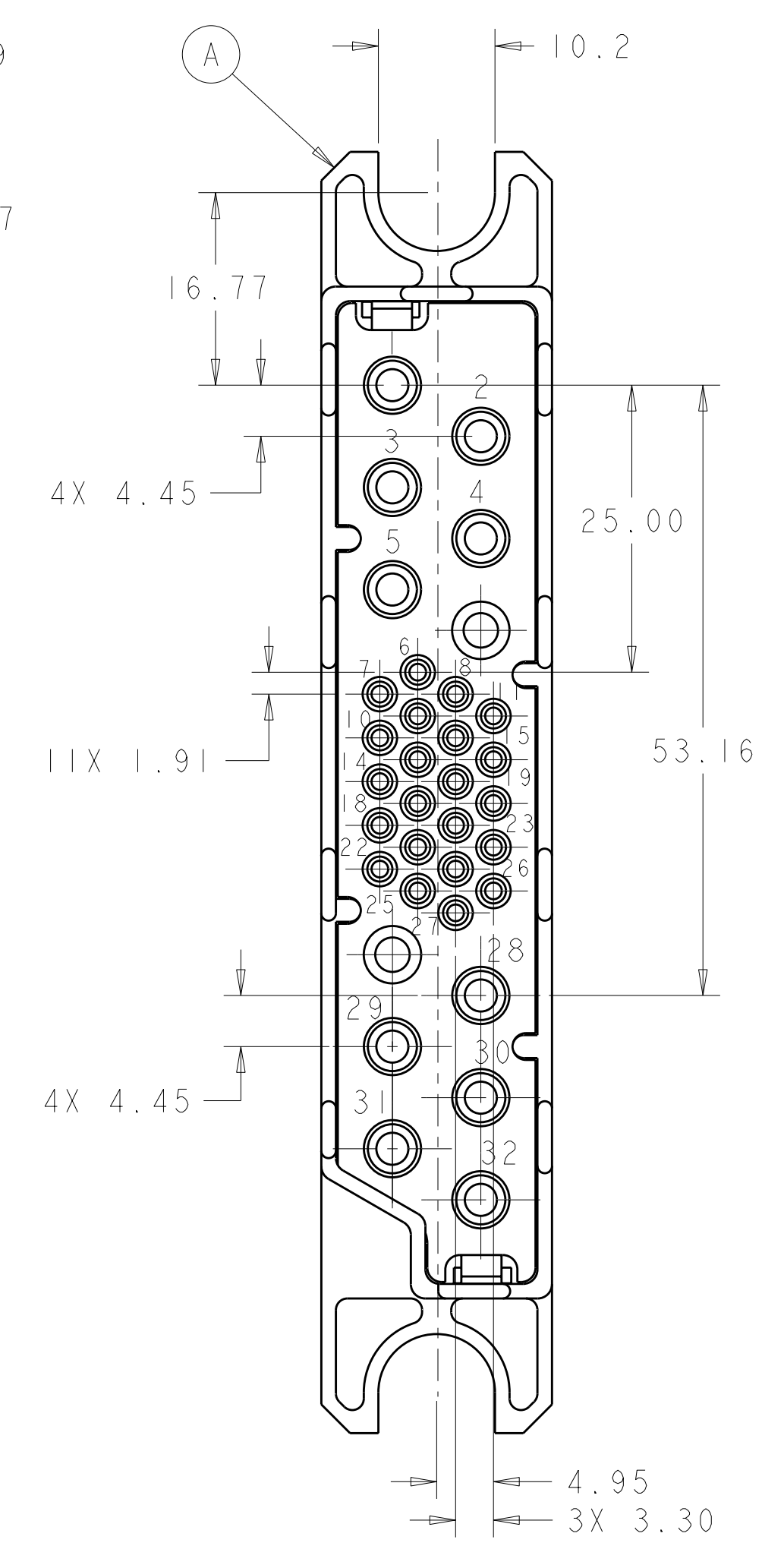
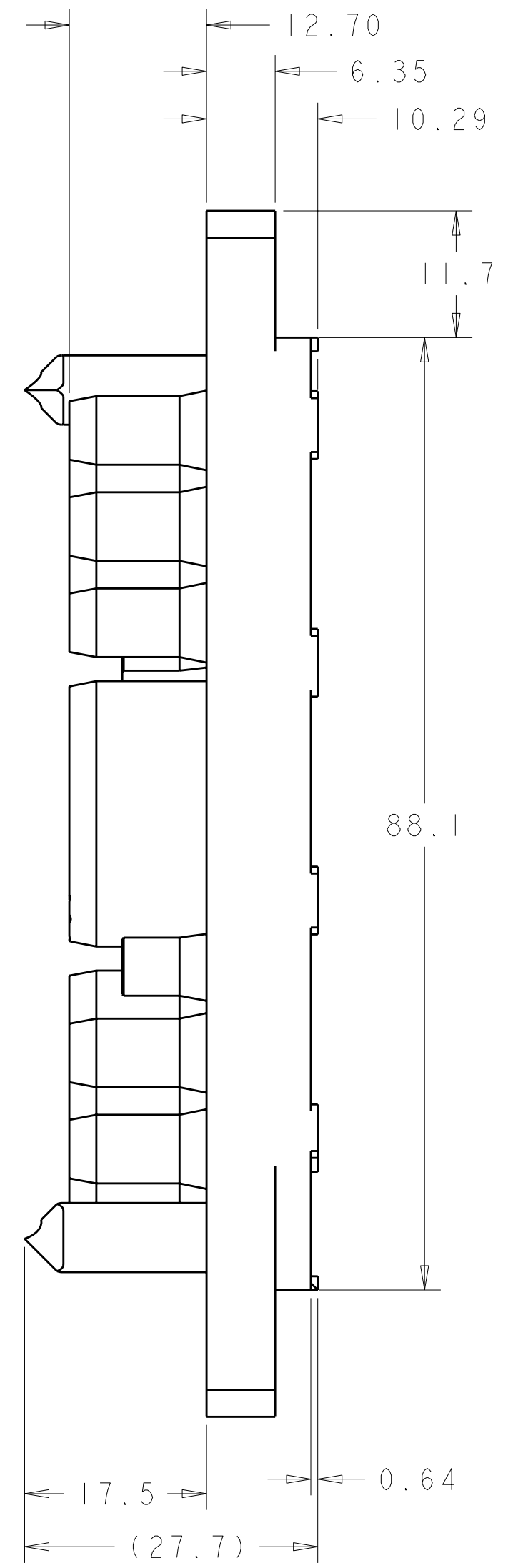
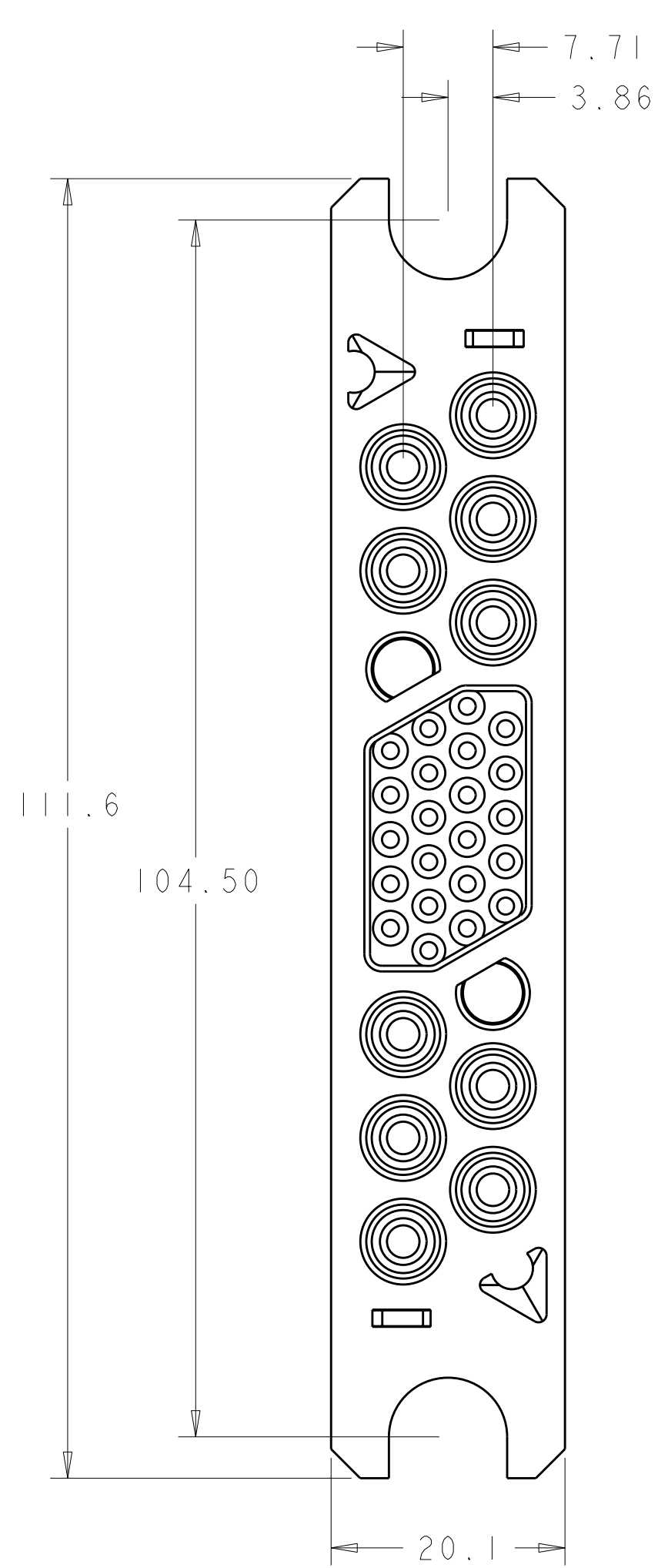

REAR VIEW

CONTACT PIN (B)
CONTACT PIN (C)
CONTACT PIN (B)

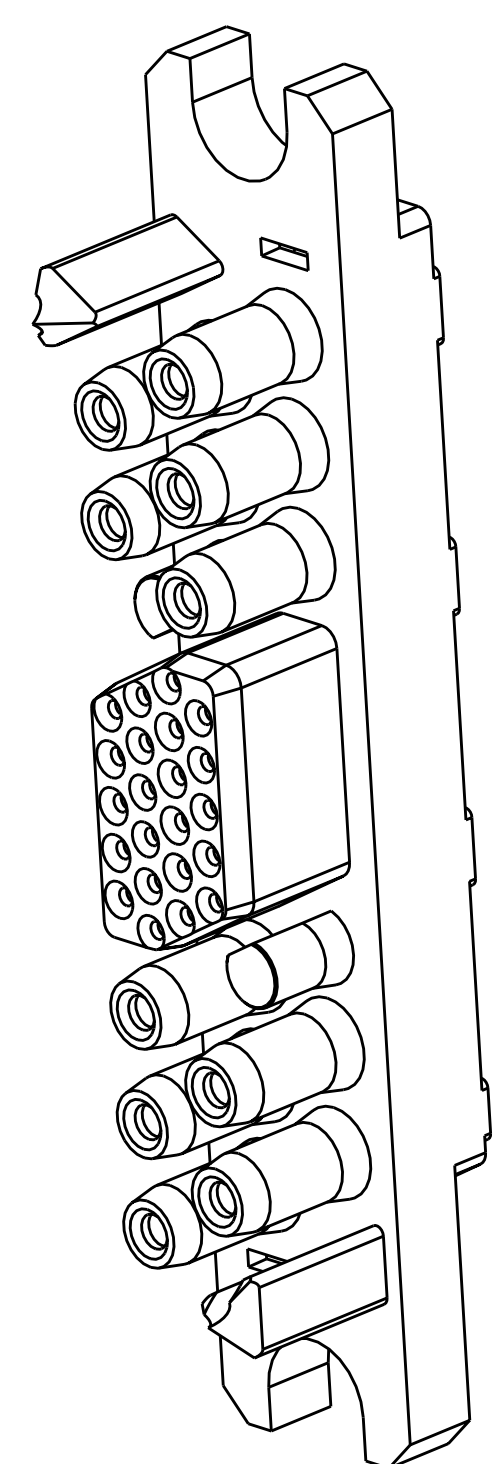

1926214-1
PRODUCT NUMBER

ELCON P10S22

THIS DRAWING IS A CONTROLLED DOCUMENT FOR TYCO ELECTRONICS CORPORATION. IT IS SUBJECT TO CHANGE AND THE CONTROLLING ENGINEERING ORGANIZATION SHOULD BE CONTACTED FOR THE LATEST REVISION.		DWN G. PETERS 16OCT2006	Tyco Electronics Harrisburg, PA 17105-3608	
DIMENSIONS: mm		CHK D. ORRIS 16OCT2006	NAME STRAIGHT SOCKET CUSTOM CONNECTOR 10X #12, 13X #20 CONTACTS	
TOLERANCES UNLESS OTHERWISE SPECIFIED: 0 PLC ±.5 1 PLC ±.5 2 PLC ±.02 3 PLC ±.010 4 PLC ±.0001 ANGLES ±.5 FINISH		APVD S. FLICKINGER 16OCT2006	SIZE A200779	
MATERIAL		PRODUCT SPEC	DRAWING NO C-1926214	
		APPLICATION SPEC	RESTRICTED TO	
		WEIGHT	SCALE 3:1 SHEET 1 OF 2 REV B	
		CUSTOMER DRAWING		

THIS DRAWING IS UNPUBLISHED. RELEASED FOR PUBLICATION 20
 © COPYRIGHT 20 BY TYCO ELECTRONICS CORPORATION. ALL RIGHTS RESERVED.

LOC	DIST	REVISIONS					
GP	00	P	LTR	DESCRIPTION	DATE	DWN	APVD
		-		SEE SHEET 1			

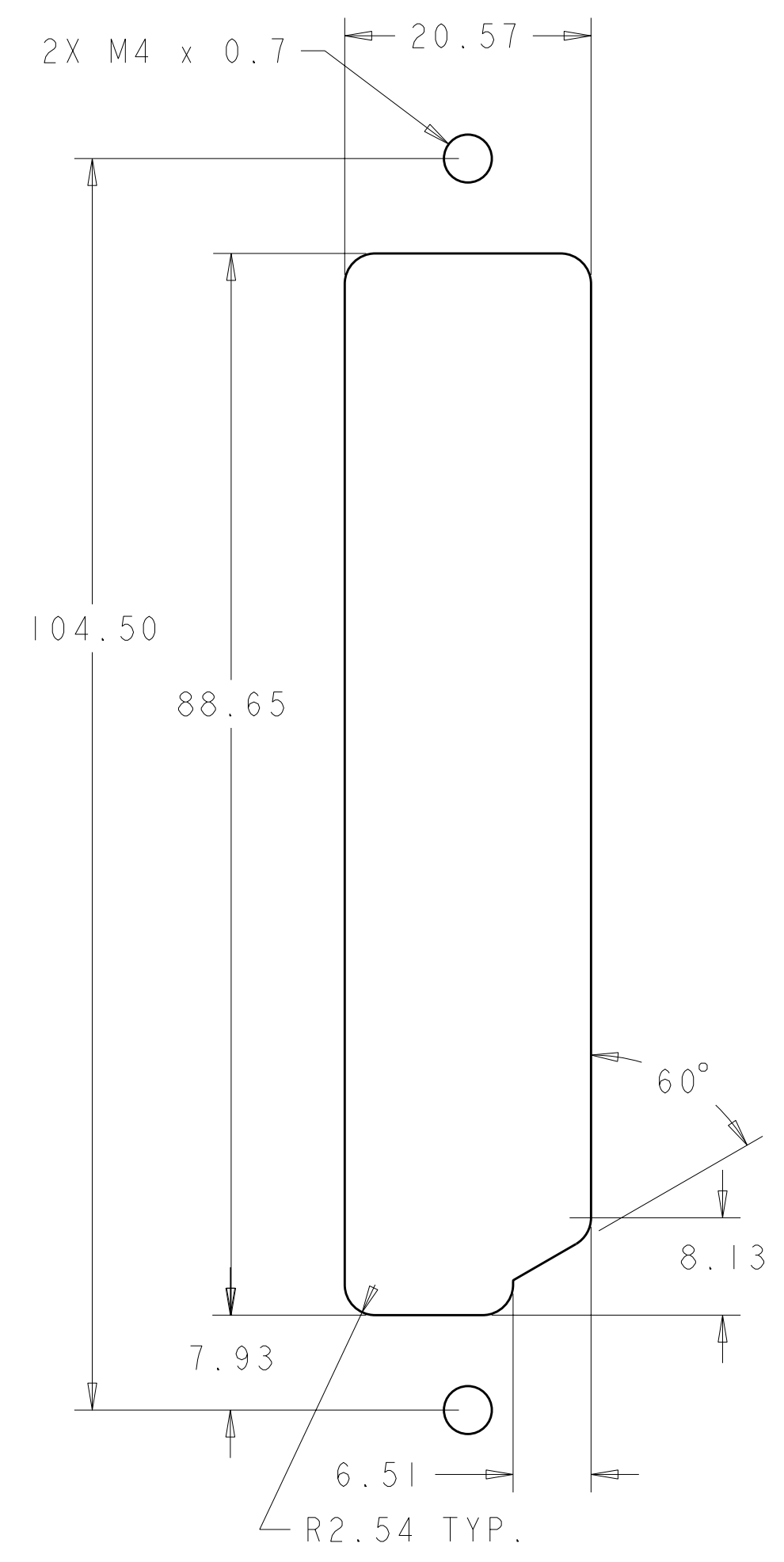

SUGGESTED PANEL CUTOUT
 VIEW FROM CONNECTOR MOUNTING SIDE

- PART NUMBER CHANGES AND OR DESIGN CHANGES AFFECTING ITEM INTERCHANGEABILITY REQUIRE PRIOR TYCO APPROVAL AND AUTHORIZATION BY REVISION TO THIS DRAWING.
- MATERIAL INSULATORS - THERMOPLASTIC, GLASS REINFORCED, COLOR: BLACK UL94V-0 FLAMMABILITY RATED.
 SOCKET CONTACTS - COPPER ALLOY
 RETENTION CLIPS: BERYLLIUM COPPER OR STAINLESS STEEL
 CROWN BAND: BERYLLIUM COPPER
 SHOULDER SCREWS: STAINLESS STEEL
- FINISH: CONTACTS - SILVER PLATE .000200 INCH MN. THICK,, OVER NICKEL .000040 INCH MIN. THK.

△ ITEM PROVIDED TO THIS SPECIFICATION TO BE PERMANENTLY IDENTIFIED PER THE FOLLOWING IDENTIFIER LABEL
 YEAR WEEK

TYCO PART NO. DATE CODE (e.g. 0106)
 XXXXXXXX-X XXXX

△5 CRIMP CONTACTS AND SHOULDER SCREWS (ITEM B) SHALL BE PACKAGED SEPERATELY AND PLACED IN THE BOX WITH THE CONNECTOR ASSEMBLY

△5	13	1648325-1	CONTACT #20, CRIMP #20	C
△5	10	6648433-1	CONTACT SOCKET #12 CRIMP #10	B
	1	1648212-2	SOCKET, CONNECTOR ASSEMBLY	A
	-1	PART NUMBER	DESCRIPTION	ITEM NO

<small>THIS DRAWING IS A CONTROLLED DOCUMENT FOR TYCO ELECTRONICS CORPORATION IT IS SUBJECT TO CHANGE AND THE CONTROLLING ENGINEERING ORGANIZATION SHOULD BE CONTACTED FOR THE LATEST REVISION.</small>		DWN G. PETERS 16OCT2006	Tyco Electronics Harrisburg, PA 17105-3608	
DIMENSIONS: mm		CHK D. ORRIS 16OCT2006	NAME STRAIGHT SOCKET CUSTOM CONNECTOR 10X #12, 13X #20 CONTACTS	
TOLERANCES UNLESS OTHERWISE SPECIFIED: 0 PLC ±.5 1 PLC ±.5 2 PLC ±.02 3 PLC ±.010 4 PLC ±.0001 ANGLES ±.5 FINISH		APVD S. FLICKINGER 16OCT2006	PRODUCT SPEC APPLICATION SPEC WEIGHT SCALE 3:1 SHEET 2 OF 2 REV B	
MATERIAL		SIZE CAGE CODE DRAWING NO RESTRICTED TO A200779C-1926214		
		CUSTOMER DRAWING		

单击下面可查看定价，库存，交付和生命周期等信息

[>>TE Connectivity\(泰科\)](#)