

THIS DRAWING IS UNPUBLISHED. RELEASED FOR PUBLICATION
 © COPYRIGHT BY TYCO ELECTRONICS CORPORATION. ALL RIGHTS RESERVED.

LOC	DIST	REVISIONS					
GP	00	P	LTR	DESCRIPTION	DATE	DWN	APVD
		A		REVISED PER ECN 0513-0326-05	24JUL06	JDP	CWR
		A1		REVISED PER ECO-10-000444	19JAN10	KK	HMR

OPENING FOR CABLE
(SEE DASH NO FOR DIA)

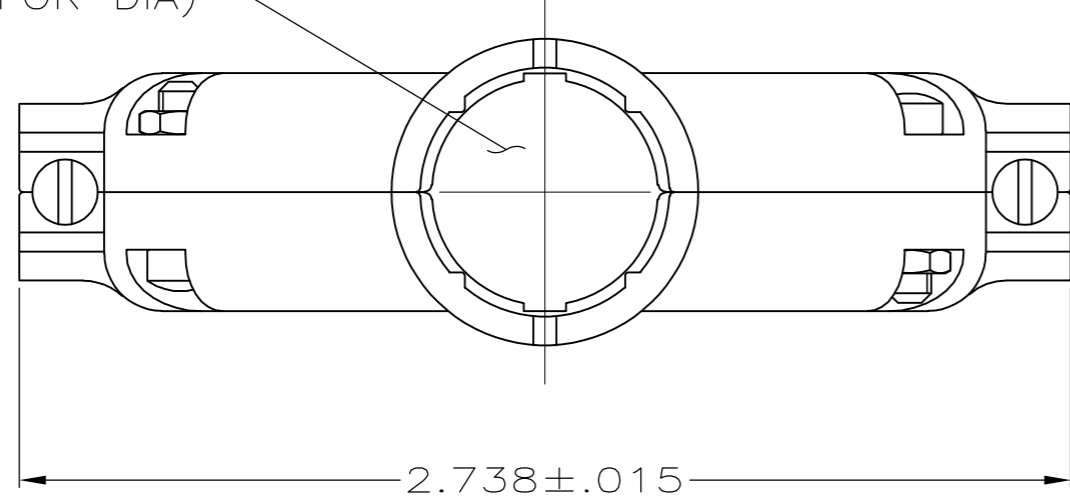

SIZE IDENTIFICATION
LETTER MOLDED HERE
(SEE TABLE)

#4-40 FILLISTER HEAD
STEEL SCREW & HEX NUT,
2 REQD.

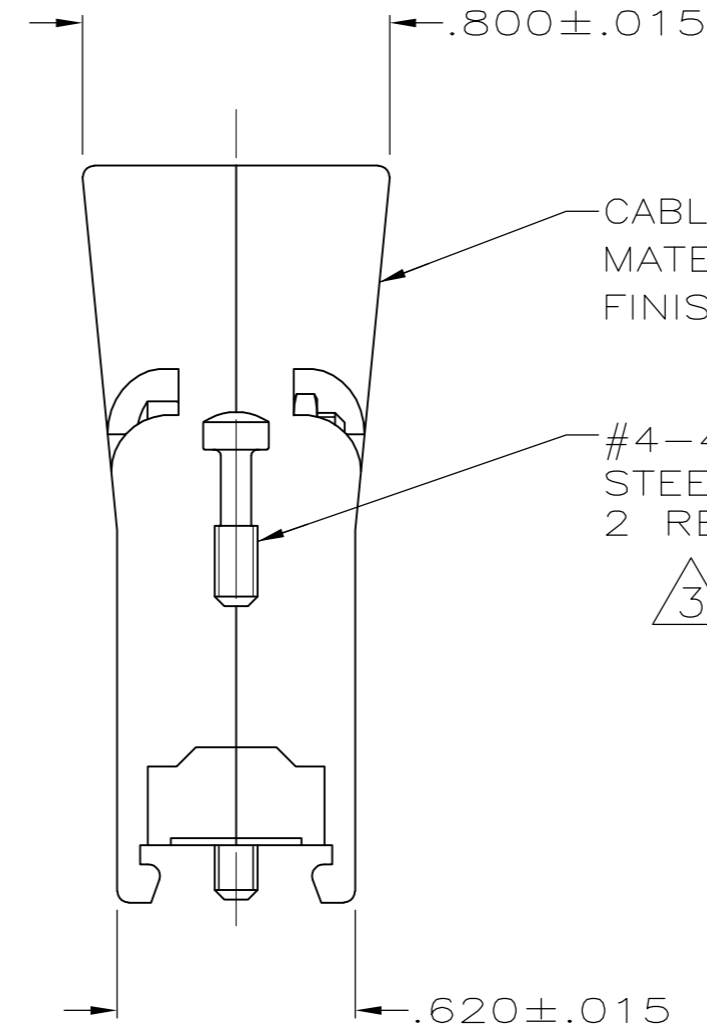
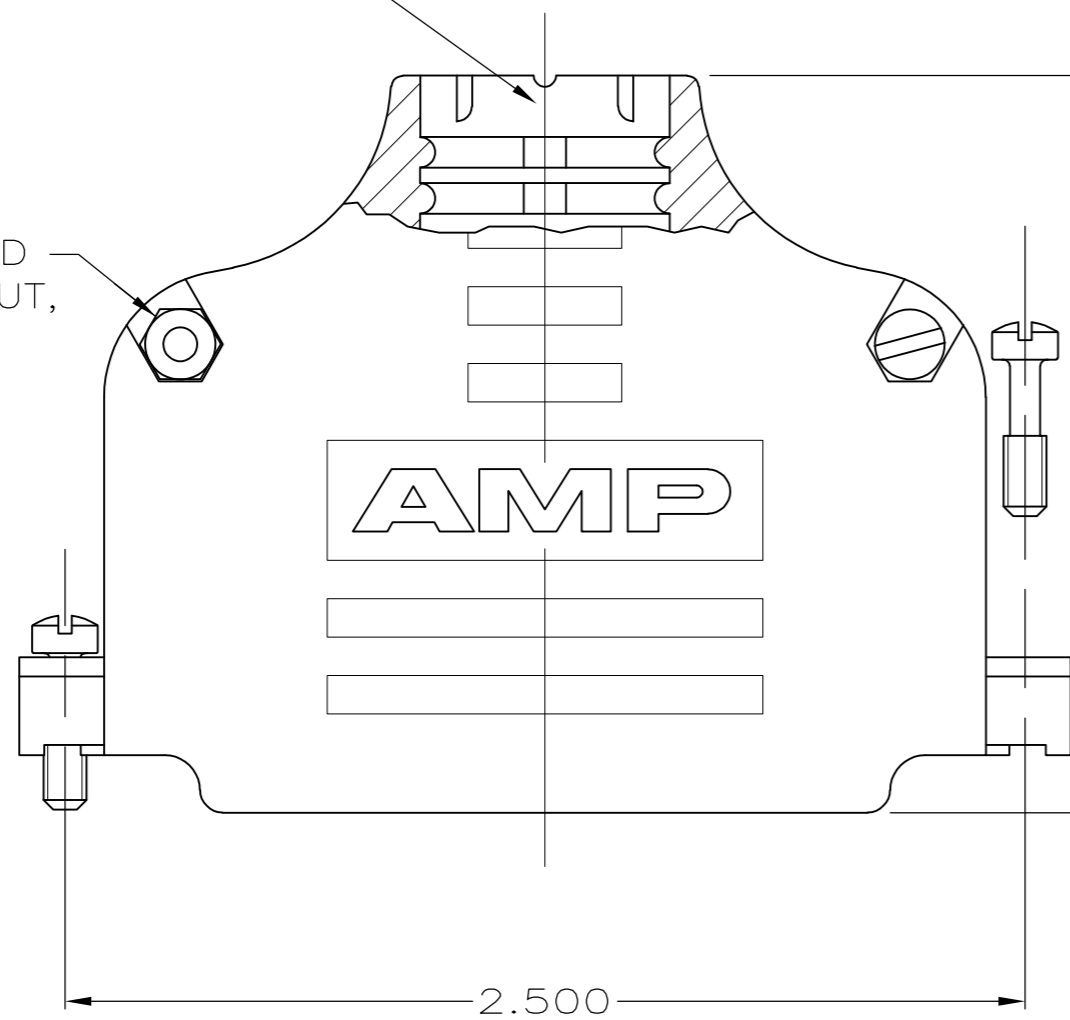

CABLE CLAMP
MATERIAL: FLAME RETARDANT THERMOPLASTIC,
FINISH: BRIGHT NICKEL OVER BRIGHT COPPER

#4-40 FILLISTER HEAD SCREW
STEEL
2 REQD.



- ALL PARTS PACKAGED UNASSEMBLED.
- THIS KIT CONSISTS OF 2 STRAIN RELIEF HALVES,
2 #4-40 SCREWS, 2 #4-40 NUTS & 2 #4-40 MOUNTING SCREWS.

ZINC PLATED .000200-.000400 THICK,
CLEAR CHROMATE COATING.

OBSOLETE PARTS: OBSOLETE CIS STREAMLINING PER D.RENAUD/D.SINISI

OBSOLETE	P	.530	1-5747100-1
OBSOLETE	F	.350	5747100-9
	J	.425	5747100-7
OBSOLETE	N	.500	5747100-5
	R	.575	5747100-3
	T	.650	5747100-1
	SIZE IDENT LETTER	CABLE DIA	PART NO.

**COPYRIGHT 2005
TYCO ELECTRONICS CORP
ALL RIGHTS RESERVED**

DIMENSIONS:		TOLERANCES UNLESS OTHERWISE SPECIFIED:		MATERIAL		FINISH	
INCHES		0 PLC	± -	SEE CALLOUTS	SEE CALLOUTS		
		1 PLC	± -				
		2 PLC	± -				
		3 PLC	± .005				
		4 PLC	± -				
		ANGLES	± -				

THIS DRAWING IS A CONTROLLED DOCUMENT.		DWN	D. HENNY	8-16-05
		CHK	C. ROHDE	8-16-05
		APVD	M. WALMSLEY	8-16-05
		PRODUCT SPEC		
		APPLICATION SPEC		
		WEIGHT	-	
		CUSTOMER DRAWING		

Tyco Electronics Corporation Harrisburg, PA 17105-3608		NAME	
CABLE CLAMP KIT, SIZE 4, 37 POSITION, 180°, AMPLIMITE SERIES, PLATED PLASTIC			
SIZE	CAGE CODE	DRAWING NO	RESTRICTED TO
A2	00779	C=5747100	-
SCALE	1:1	SHEET	1 of 1
REV	A1		

单击下面可查看定价，库存，交付和生命周期等信息

[>>TE Connectivity\(泰科\)](#)