

## Specifications

Power requirement	115 V model	110 to 120 V
	230 V model	220 to 240 V
Air requirement	60 psi, minimum	
	4 cfm	
	Clean, dry, oil-free (recommended filters: Raychem 979673, Norgren F44 or F40)	
Output air temperature	See graphs	

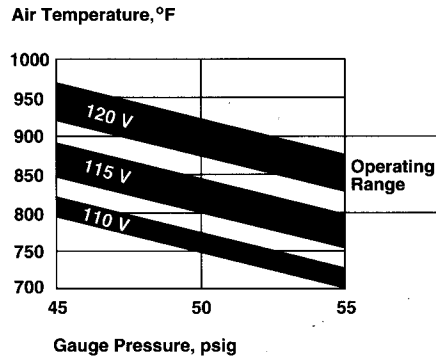

Output air temperature vs. line voltage and air pressure (115 V model)

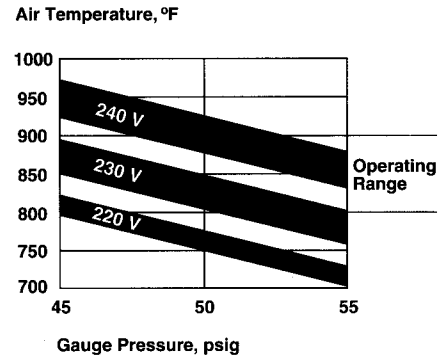

Output air temperature vs. line voltage and air pressure (230 V model)

## Installation instructions

### Step 1

Attach the fitting on the control unit to a clean, dry, oil-free compressed-air source capable of supplying 4 ft<sup>3</sup>/min at 60 psi minimum. (The AA-400 Super Heater is supplied with one of the more popular quick-disconnect air fittings. However, it may be necessary to replace it with one that will mate with your particular fittings.)

### Note

Failure to use clean, dry, oil-free air may result in severe damage to the AA-400.

### Step 2

Connect the electrical cord to the power source noted on the unit's label (115 V or 230 V).

### Step 3

Adjust the air-pressure control knob for a gauge reading of 50 psi. (The red plastic ring below the control knob must be

raised to unlock the knob; clockwise rotation of the knob increases the air pressure.)

### Note

Power is applied to the heating element only when the air pressure supplied to the heat gun exceeds approximately 45 psi. A pressure switch cuts off the power to the element when the air pressure drops below this point, protecting the heat gun from damage due to overheating. The HEAT ON indicator light is illuminated whenever power is applied to the heating element. This light goes off when the pressure switch cuts off power to the element.

### Step 4

Within 30 seconds, air emitted from the nozzle tip should be hot (above 500°F); within one minute it should stabilize at the operating temperature. See graphs for

air-temperature ranges at various air-pressure/voltage combinations.

### Note

Air passing through the eight small holes in the nozzle cools the plastic handle. Under no circumstances should these small holes be closed.

### Step 5

Important: To turn the unit off, first reduce the air pressure to 30 psi for one minute. (The red indicator light will go off when the pressure drops below approximately 45 psi, indicating that power has been removed from the heating element.) After one minute at 30 psi, reduce the air pressure to zero.

### Note

Failure to follow this shut-down procedure may cause premature element failure or heat damage to the plastic housing.

## Operating instructions

### Note

Never leave this device unattended.

### Step 1

If a reflector is required for your application, install it while the heat-gun nozzle is cool and power to the element is off. See Raychem Bulletin H-138 and Step 6 below for details on reflectors and tips.

### Step 2

Follow steps 1 through 4 of the installation instructions to prepare the heater for operation. When you are not using the heat gun, place it on its stand to avoid possible damage to surroundings.

### Note

Avoid aiming the hot air stream at the unit's hose or power cord.

### Step 3

If the air temperature appears to be too high for your particular application, increase the air pressure. If the air temperature is still too high at the maximum pressure setting, it will be necessary to reduce the voltage with a variable transformer capable of handling a 400-watt load.

## Operating instructions (continued)

### Step 4

If the air temperature appears to be too low for your application, decrease the air pressure. If the air pressure is still too low at the minimum pressure setting (about 45 psi), check your power source voltage.

### Note

If you elect to use a variable transformer to correct for a low voltage problem, do not exceed the 120 V or 240 V rating of your Super Heater.

For 115 V models, check the electrical resistance of the element. If it exceeds 50 ohms, it must be replaced.

### Step 5

For SolderPak® applications, the end of the nozzle or attached reflector should be about 1/4" to 1/2" away from the SolderSleeve devices, with the hot air

stream directed at the solder. Closer placement of the nozzle tip can result in browning of the tubing or squirting of the melted solder.

### Step 6

The needle point and low-flow point tips and the SolderSleeve and mini SolderSleeve reflectors are designed to slip over the small-diameter end of the nozzle. The needle point tip reduces the heated air flow rate and air stream diameter by about 50 percent (the rest of the heated air is deflected back into the cooling air stream). The low-flow point tip reduces the heated air flow rate about 70 percent in a similar fashion. The SolderSleeve reflector distributes all of the heated air around the slot opening for uniform heating of the standard size SolderSleeve devices. The mini SolderSleeve reflector concentrates the hot air flow in a small area for smaller Solder-

Sleeve devices. The boot and tubing tip is designed to slip over the large diameter of the nozzle, so that the cooling air emitted from the eight small holes mixes with the hot air. This reduces the air temperature approximately 200°F and significantly increases the air flow rate, allowing recovery of Thermostat® heat-shrinkable molded parts and tubing.

### Step 7

To turn the Super Heater off, follow Step 5 of the Installation Instructions.

### Note

Never disconnect an operating Super Heater from its air supply without first allowing the element to cool, as directed in step 5 of the installation instructions. Failure to observe this precaution will reduce element life and could lead to melting of the plastic handle.

## Heating element replacement instructions (refer to Figure 1 for component part identification)

### Note

The following procedures should be performed by qualified personnel only.

### Step 1

Disconnect the unit from its electrical power and compressed-air sources.

### Step 2

Remove the manifold cover screw and slide the manifold cover down the hose assembly and away from the handle body.

### Step 3

Pull the ground clip off the rear of the heating element.

### Step 4

Remove the two terminal screws. This releases the power lead wires and heating-element lead wires from the terminal inserts in the handle body.

### Step 5

Remove the old heating element from the rear of the handle body by pulling on the element lead wires with pliers, or by pushing with a 1/8" diameter rod through the nozzle. If the insulating bushing should come out with the old element, discard it.\*

### Step 6

Install the replacement heating element into the handle body as follows:

- Lubricate both rubber O-rings lightly with silicone grease.
- If the insulating bushing came out with the old element, place a new bushing on the tip of the new element for assembly.\*
- Insert the heating element into the rear of the handle body.
- Push with your fingers on the rear of the element to start the first O-ring into the handle body.

\*Mark III only.

- Complete insertion by pushing on the rear of the element with a small screwdriver placed between the element lead wires. Keep pushing on the element until the front end of the element seats in the nozzle. The element is seated when it is approximately 1 inch underflush in the handle body.

### Step 7

Fasten the element lead wires and power lead wires to the terminal inserts using the two terminal screws.

### Step 8

Attach the ground clip to the rear of the

element. Be certain that the ground clip is firmly attached to the heating element.

### Step 9

Slide the manifold cover up the hose assembly to its proper position on the handle body.

### Note

Avoid pinching the pressure-sensing hose, and keep the power lead wires and ground wire from obstructing the pathway of the manifold cover screw.

### Step 10

Fasten the manifold cover to the handle body using the manifold cover screw.

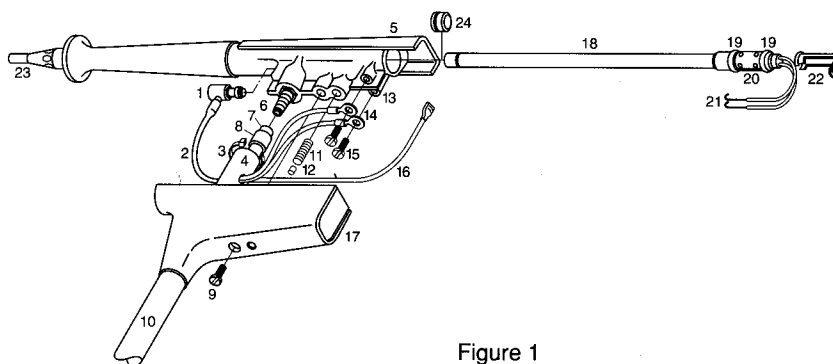

Figure 1

- Pressure sensing hose fitting
- Pressure sensing hose
- Wire tie
- Woven sleeving
- Handle body
- Barbed fitting
- Air/nitrogen hose
- Threaded sleeve
- Manifold cover screw
- Hose assembly
- Calibration screw
- Silicone rubber seal
- Terminal inserts
- Power lead wires
- Terminal screws
- Ground lead
- Manifold cover
- Heating element
- O-rings
- Metal spacer (slot must face towards terminal inserts)
- Element lead wires
- Ground clip with screw
- Nozzle
- Insulating bushing\*

**Heating element replacement instructions (continued)**

**Step 11**

Attach the unit to its compressed-air source. Adjust the air pressure to 55 psi and check for balanced air flow through the nozzle and the eight small cooling-air holes.

**Note**

If most of the air flows from the end of the nozzle, the element was not properly seated in the nozzle (Step 6e). If most of the air flows from the eight small holes, the bushing was not installed.\*

**Step 12**

If the air flow through the nozzle and the eight small holes appear to be balanced, connect the unit to its power source.

**Step 13**

Verify that sufficient air is flowing through the heating element. Wearing safety glasses, carefully look into the end of the nozzle and observe the color of the heating element with the unit operating at 50 psi and connected to its power source.

**Note**

If the element glows brighter than cherry red, insufficient air is flowing through the heating element. Immediately do the following: Reduce the air pressure to 30 psi; allow the unit to cool; disconnect the unit from its power source. This overheating condition requires air flow calibration by a Raychem authorized service center.

\*Mark III only.

**Parts list**

**Accessories**

Description	Part Number
Stand assembly	979649
SolderSleeve reflector	979646
Needle point tip	979647
Boot and tubing tip	979691
Mini SolderSleeve reflector	979663
Low-flow point tip	979672
Input air filter	979673

Replacement Parts Description	Model	Part Number	
		Mark II	Mark III
Heat gun/air hose replacement kit (includes heat gun, hose assembly, heating element, instructions)	115 V	837665	837665
	230 V	563757	563757
Heating element replacement kit (includes instructions)	115 V		013750
	230 V		925613
Control unit replacement kit (includes control unit, power cord, instructions)	115 V	566884	566884
	230 V	913846	913846

**Raychem Corporation  
Electronics Group**  
300 Constitution Drive  
Menlo Park, California 94025-1164  
1-800-2-RAYCHEM, x1500  
(1-800-272-9243, x1500)

*All of the above information, including illustrations, is believed to be reliable. Users, however, should independently evaluate the suitability of each product for their application. Raychem makes no warranties as to the accuracy or completeness of the information, and disclaims any liability regarding its use. Raychem's only obligations are those in the Standard Terms and Conditions of Sale for this product, and in no case will Raychem be liable for any incidental, indirect, or consequential damages arising from the sale, resale, use, or misuse of the product.*

Revision: A

单击下面可查看定价，库存，交付和生命周期等信息

[>>TE Connectivity\(泰科\)](#)