

THIS DRAWING IS UNPUBLISHED. RELEASED FOR PUBLICATION
 © COPYRIGHT BY TYCO ELECTRONICS CORPORATION. ALL INTERNATIONAL RIGHTS RESERVED.

| LOC | DIST | REVISIONS | | | | | |
|-----|------|-----------|-----|---------------|----------|-----|------|
| | | P | LTR | DESCRIPTION | DATE | DWN | APVD |
| H | - | | A | WO 00/7012 | 20-07-00 | - | VS |
| | | | B | SR10-0250-02 | 24-05-02 | - | BC |
| | | | B1 | ECR-09-015706 | 24-11-09 | AEG | MKO |

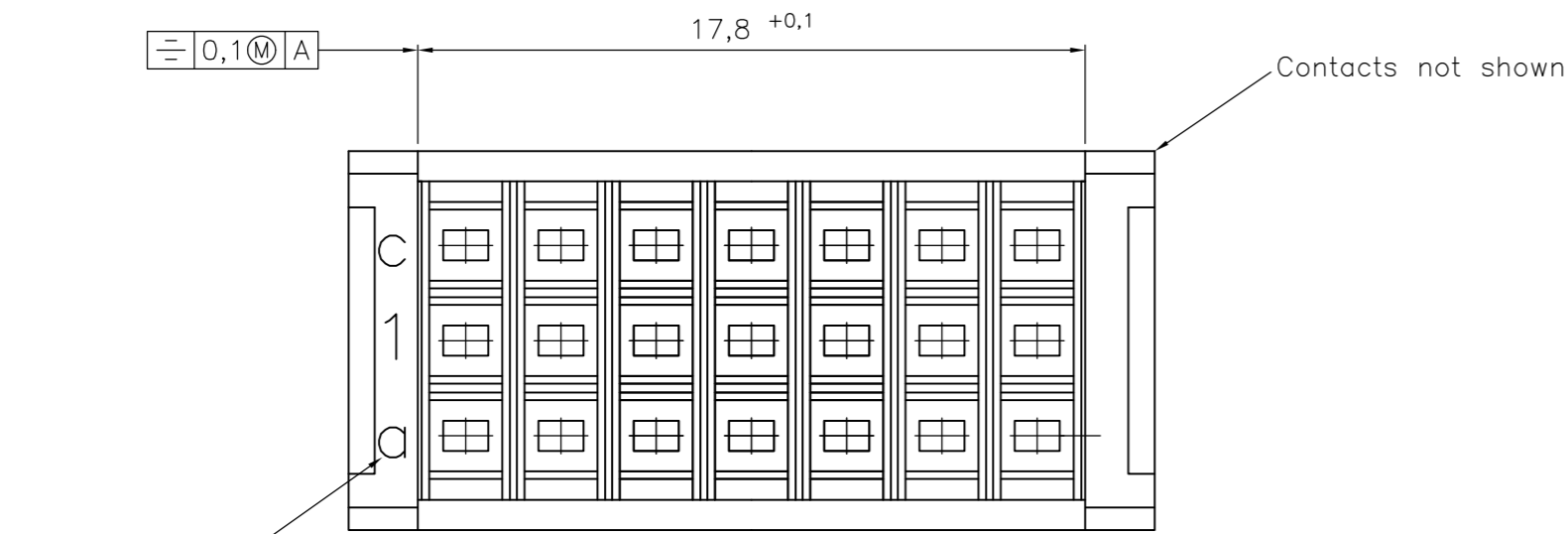

Marking E2-8
 DIN 30640;
 0.2 raised.

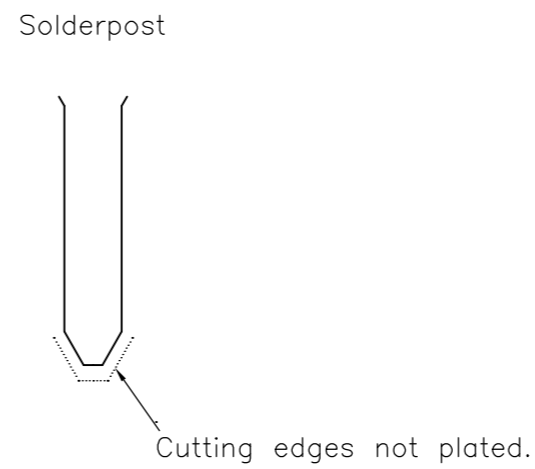

Loading Pattern (8 contacts)

| | 1 | 2 | 3 | 4 | 5 | 6 | 7 |
|-------|---|---|---|---|---|---|---|
| Row a | + | o | + | o | + | o | + |
| Row b | o | o | o | o | o | o | o |
| Row c | + | o | + | o | + | o | + |

+ = contact
 o = no contact

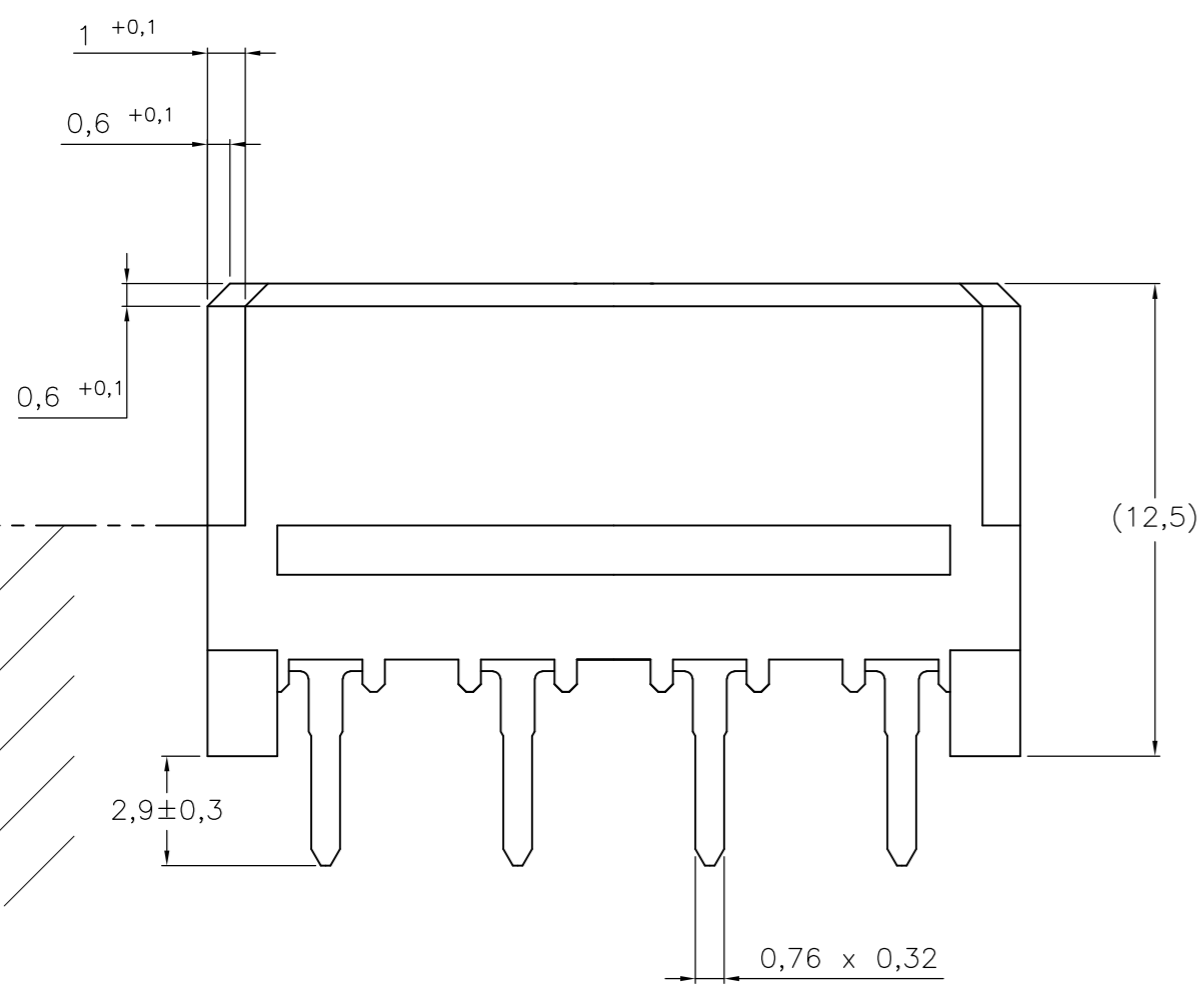

IMMERSION-DEPTH
 FOR ANTI-FLUX TREATMENT

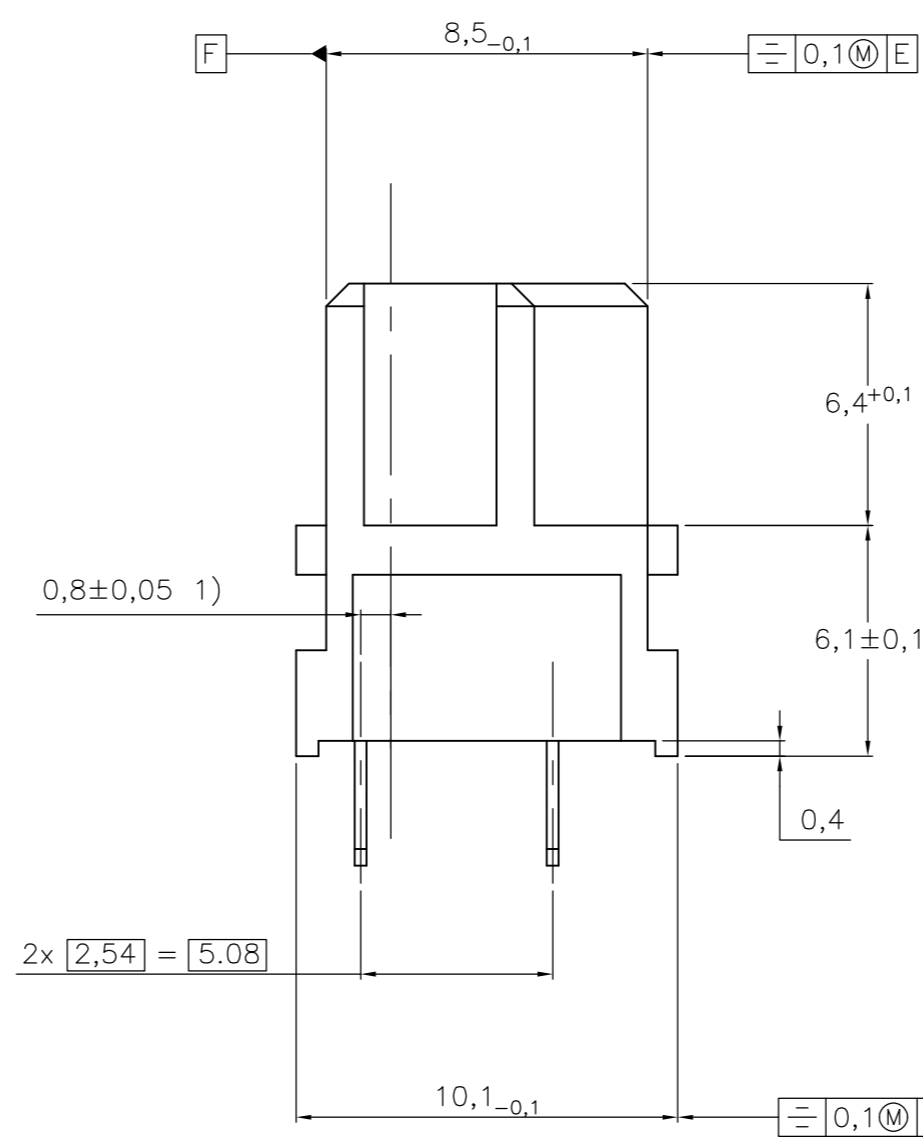

Specifications acc. IEC 603-2. Performance Level 2

Housing : PBTP 30% Glasfilled (UL94-V0)
 Pebblegrey similar RAL 7032
 Contact material : Copper Alloy
 Plating : Contact area : PdNi+Au or Au
 Termination area : Sn
 with flux-tight coating.

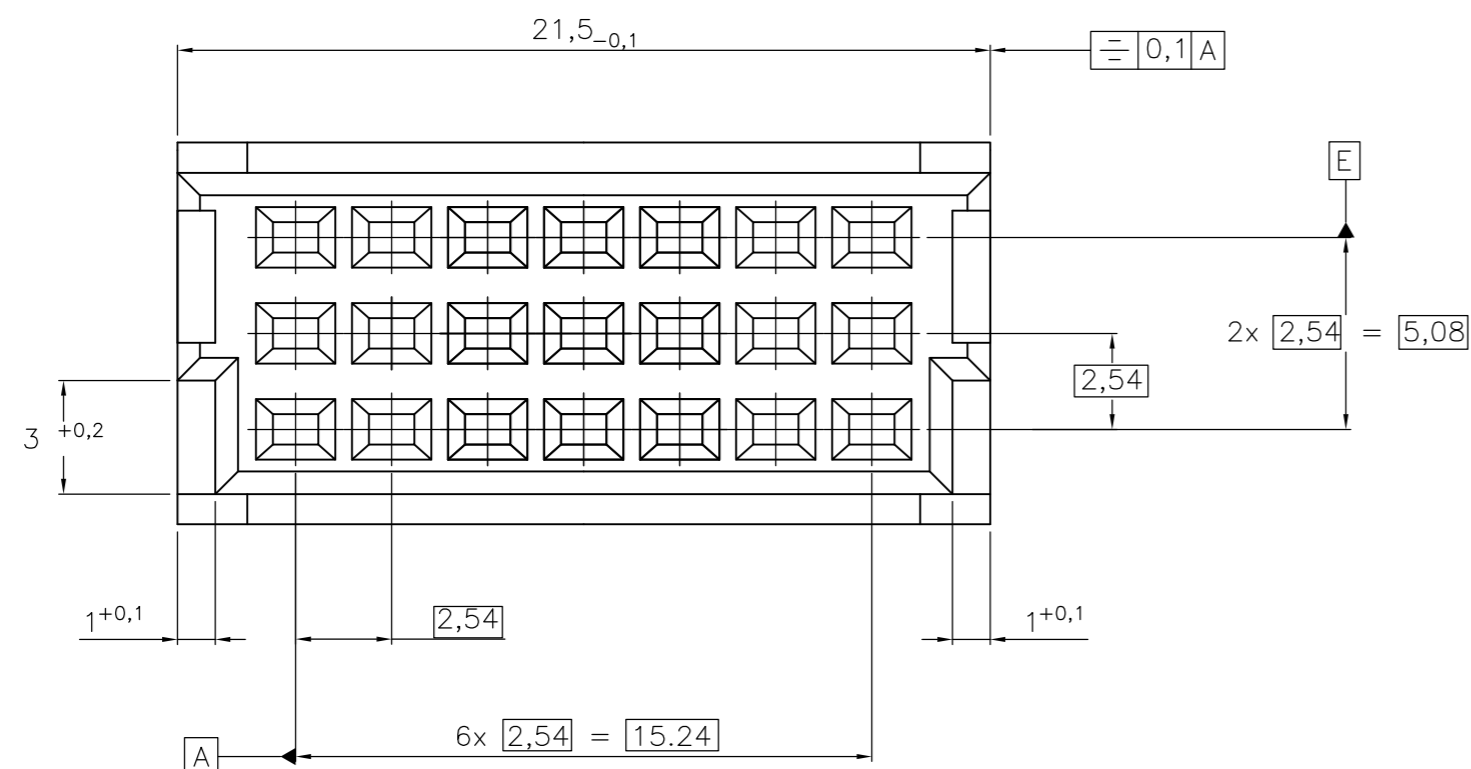

1) Center-displacement between termination- and contact-side.

Active Partnumber. Contact
 Tyco Electronics for other
 configuration availability

| Old Partnumber | TE Partnumber |
|-----------------|---------------|
| V42254-F2299-R1 | 1393657-1 |

| | | | | | |
|---|-------------|-------------------|-----------------------|--|---------------------------|
| THIS DRAWING IS A CONTROLLED DOCUMENT. | | DWN Cuvelier | 10JUN98 | Tyco Electronics Corporation s-Hertogenbosch, Nederland | |
| DIMENSIONS: mm | | CHK - | APVD PD COM | NAME Receptacle Ass'y, Type R, 21 pos. | |
| TOLERANCES UNLESS OTHERWISE SPECIFIED: 0 PLC ± - 1 PLC ± - 2 PLC ± - 3 PLC ± - 4 PLC ± - ANGLES ± - | | PRODUCT SPEC - | APPLICATION SPEC - | V42254-F2299-R1-* -26 | |
| MATERIAL - | FINISH - | WEIGHT - | SIZE A2 | CAGE CODE 00779 | DRAWING NO C=1393657-1 |
| CUSTOMER DRAWING | | | SCALE 5:1;10:1 | SHEET 1 of 1 | REV B1 |

单击下面可查看定价，库存，交付和生命周期等信息

[>>TE Connectivity\(泰科\)](#)