

THIS DRAWING IS UNPUBLISHED. RELEASED FOR PUBLICATION
 © COPYRIGHT - By - ALL RIGHTS RESERVED.

REVISIONS					
P	LTR	DESCRIPTION	DATE	DWN	APVD
AA1		REVISED PER ECO-17 007400	29NOV2017	RS	DR
AA2		REVISED PER ECO-19-007720	21MAY2020	KR	DR

AMP WIRE RANGE	 Listed FILE E13288	 LR7189 Certified
22-16 AWG SOLID OR STRANDED	22-16 AWG STRANDED	22-16 AWG SOLID OR STRANDED

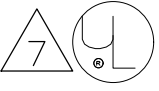
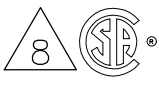
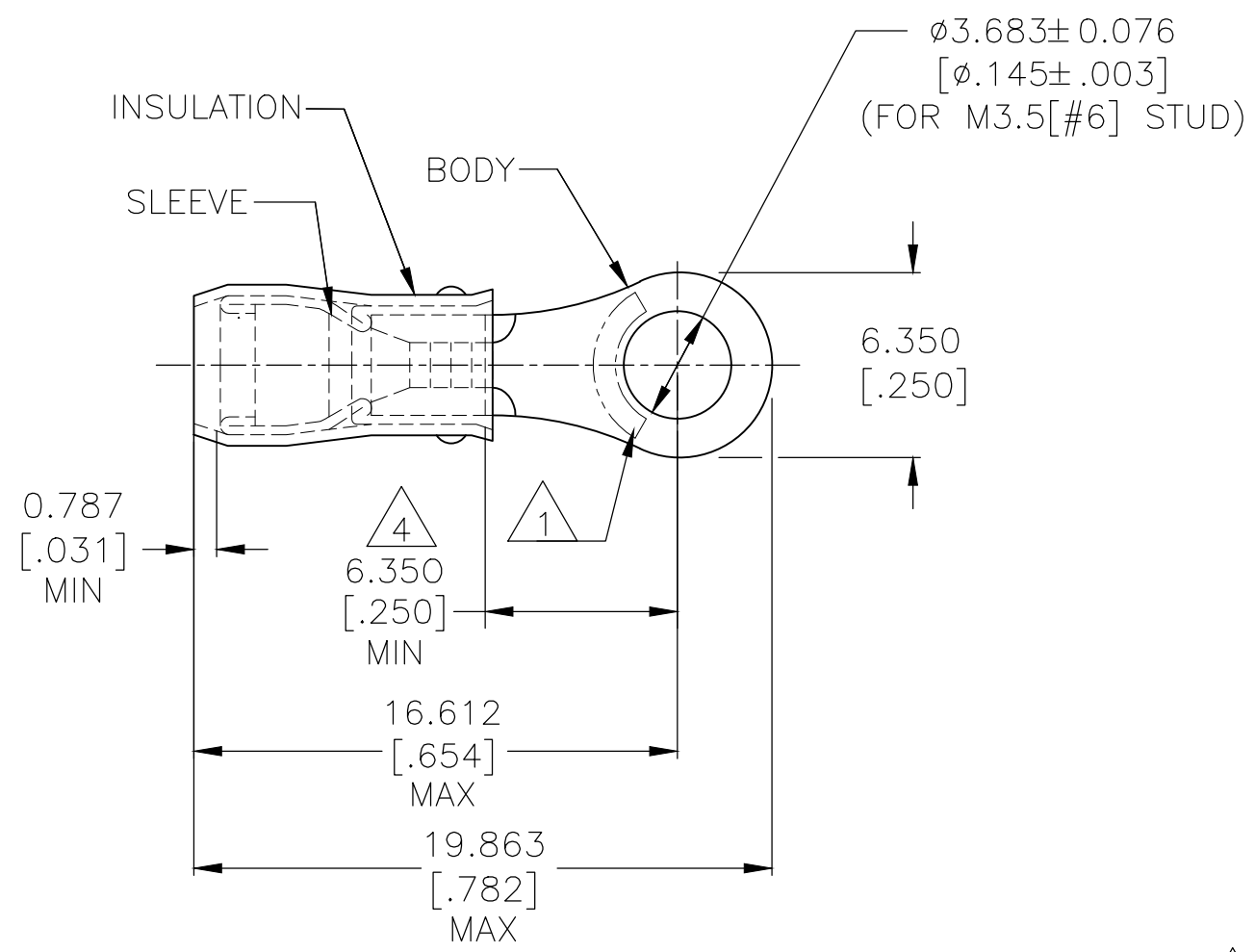

- 1 STAMP AMP 22-18* APPROX AS SHOWN
22-16 TERMINALS ARE STAMPED 22-18 IN
ACCORDANCE WITH MILITARY SPEC SAE- AS7928
COMMERCIAL WIRE RANGE IS 22-16.
- 2 WIRE INSULATION: $\phi 2.032-3.175[\phi .080-.125]$.
- 3 BODY MATERIAL THK: $0.787 \pm 0.051[.031 \pm .002]$.
- 4 DIMENSION APPLIES FROM EDGE OF METAL
WIRE BARREL TO CENTER OF STUD HOLE.
- 5 BODY & SLEEVE - COPPER PER ASTM B-152
INSULATION - NYLON.
- 6 BODY & SLEEVE - TIN PLATE PER ASTM B545,
 $0.00254[.000100]$ MIN EXT THK
INSULATION - COLOR, RED.
- 7 UL LISTED.
- 8 CSA CERTIFIED.

MILITARY P/N AND CLASS	QTY	PACKAGE TYPE	PART NUMBER
--	100	LOOSE PIECE, BOX	7-51863-1
MS25036-102 CLASS 2	5000	ON TAPE, REEL	51863-1
MS25036-102 CLASS 1 & 2	1000	LOOSE PIECE	51863

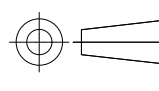
AMP INCORPORATED CUSTOMER SERVICE SYSTEMS		MAX RECOMMENDED OPERATING TEMPERATURE: 105°C[221°F] MAX	THIS DRAWING IS A CONTROLLED DOCUMENT.		DWN DK SCHRUM 9/8/93	 TE Connectivity						
FOR ADDITIONAL PRODUCT INFORMATION OR COPIES OF DRAWINGS AND TECHNICAL DOCUMENTS	PRODUCT INFORMATION CENTER 1-800-522-6752	VOLTAGE RATING: 300V MAX	DIMENSIONS: mm [INCHES]	TOLERANCES UNLESS OTHERWISE SPECIFIED: 0 PLC ± - 1 PLC ± - 2 PLC ± - 3 PLC ± 0.127[.005] 4 PLC ± - ANGLES ± -	CHK RE HERSEY 9/8/93					NAME M BARNABA 9/8/93		
FOR APPLICATION TOOLING INFORMATION	TOOLING ASSISTANCE CENTER 1-800-722-1111	CIRCULAR MIL AREA: 0.26-1.65mm²[509-3260]CIR MILS SOLID OR STRANDED		FINISH	APVD M BARNABA 9/8/93	PRODUCT SPEC UL 486 A-B						
FOR ORDER ENTRY	1-800-526-5142	THIS DRAWING IS A CONTROLLED DOCUMENT FOR AMP INCORPORATED. IT IS SUBJECT TO CHANGE AND THE CONTROLLING ENGINEERING ORGANIZATION SHOULD BE CONTACTED FOR THE LATEST REVISION.	MATERIAL	5	APPLICATION SPEC 114-2157	SIZE A3	CAGE CODE 00779	DRAWING NO C-51863	RESTRICTED TO	SCALE NTS	SHEET 1 OF 2	REV AA2



THIS DRAWING IS UNPUBLISHED. RELEASED FOR PUBLICATION
 © COPYRIGHT - By - ALL RIGHTS RESERVED.

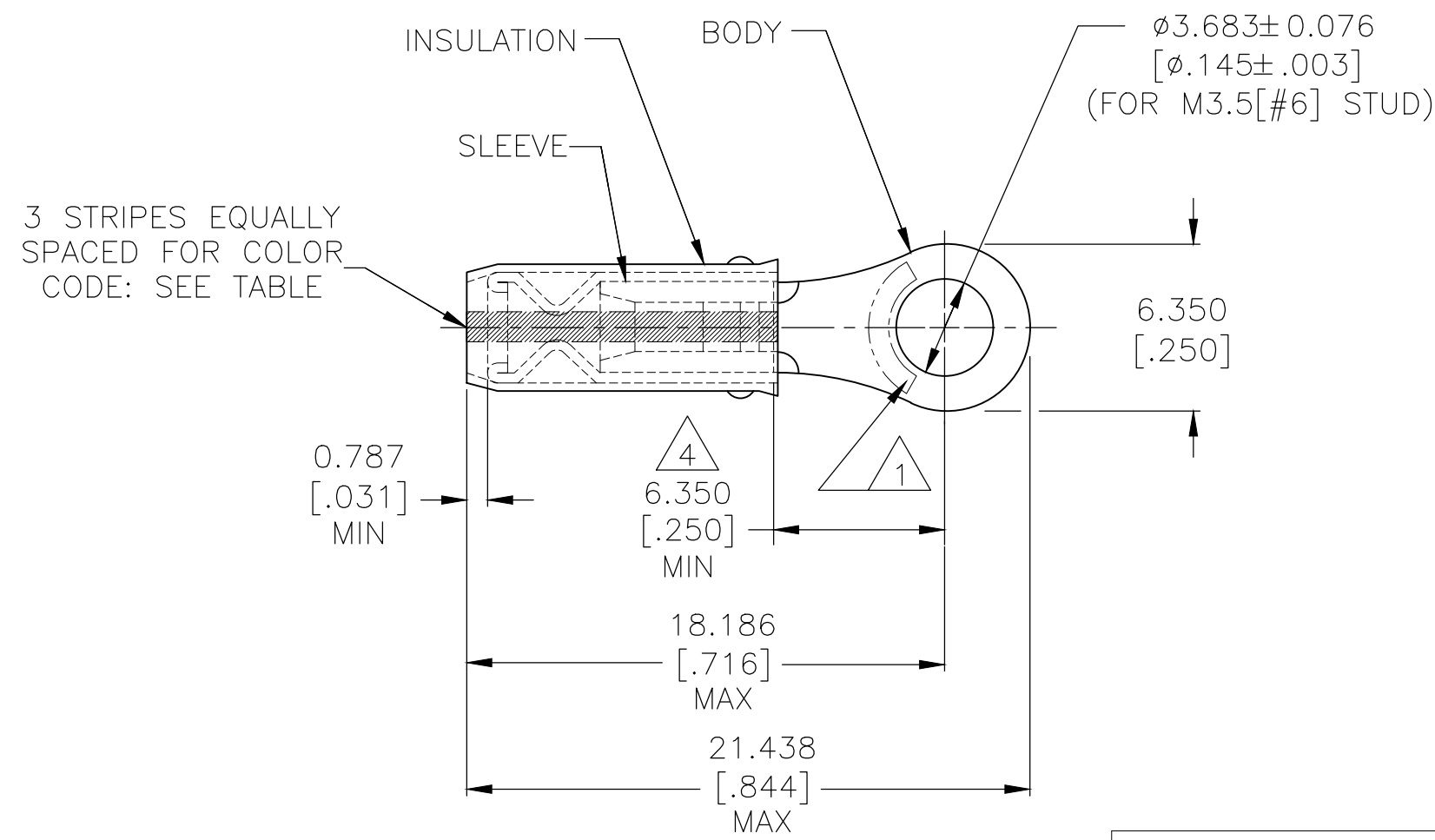

REVISIONS					
P	LTR	DESCRIPTION	DATE	DWN	APVD
-	-	SEE SHEET 1	-	-	-

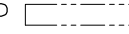
AMP WIRE RANGE	 LR 7189 Certified
SEE TABLE STRANDED	WIRE SIZE PER TABLE STRANDED

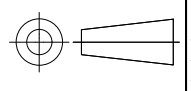

- 1 STAMP AMP  APPROX AS SHOWN SEE TABLE BELOW.
- 2 WIRE INSULATION : $\phi 0.965 - 2.794 [\phi .038 - .110]$ FOR 22 AWG
 $\phi 1.168 - 2.794 [\phi .046 - .110]$ FOR 20 AWG
 $\phi 1.422 - 2.794 [\phi .056 - .110]$ FOR 18 AWG.
- 3 BODY MATERIAL THK: $0.787 \pm 0.051 [\ .031 \pm .002]$.
- 4 DIMENSION APPLIES FROM EDGE OF METAL WIRE BARREL TO CENTER OF STUD HOLE.
- 5 BODY & SLEEVE - COPPER PER ASTM B-152 INSULATION - NYLON.
- 6 BODY & SLEEVE - TIN PLATE PER ASTM B545, $0.00254 [\ .000100]$ MIN EXT. THK INSULATION - COLOR - RED.
- 7 NOTE DELETED
- 8 CSA CERTIFIED.

	M7928/1-31 CLASS 2	WHITE	18*	18	5000	ON TAPE, REEL	51863-7
	M7928/1-13 CLASS 2	GREEN	22*	22	5000	ON TAPE, REEL	51863-5
	M7928/1-31 CLASS 1 & 2	WHITE	18*	18	1000	LOOSE PIECE	51863-4
	M7928/1-22 CLASS 1 & 2	RED	20*	20	1000	LOOSE PIECE	51863-3
	M7928/1-13 CLASS 1 & 2	GREEN	22*	22	1000	LOOSE PIECE	51863-2
	MILITARY P/N AND CLASS	STRIPE COLOR	 STAMPING	WIRE SIZE	QTY	PACKAGE TYPE	PART NO.

AMP INCORPORATED CUSTOMER SERVICE SYSTEMS		MAX RECOMMENDED OPERATING TEMPERATURE: 105°C[221°F] MAX	THIS DRAWING IS A CONTROLLED DOCUMENT.		DWN DK SCHRUM 9/8/93	 TE Connectivity				
FOR ADDITIONAL PRODUCT INFORMATION OR COPIES OF DRAWINGS AND TECHNICAL DOCUMENTS	PRODUCT INFORMATION CENTER 1-800-522-6752	VOLTAGE RATING: 300V MAX	DIMENSIONS: mm [INCHES]	TOLERANCES UNLESS OTHERWISE SPECIFIED: 0 PLC ± - 1 PLC ± - 2 PLC ± - 3 PLC ± 0.127[.005] 4 PLC ± - ANGLES ± -	CHK RE HERSEY 9/8/93				NAME M BARNABA	
FOR APPLICATION TOOLING INFORMATION	TOOLING ASSISTANCE CENTER 1-800-722-1111	CIRCULAR MIL AREA: 0.26-1.65mm²[509-3260]CIR MILS SOLID OR STRANDED		FINISH	APVD M BARNABA 9/8/93	PRODUCT SPEC -				
FOR ORDER ENTRY	1-800-526-5142	THIS DRAWING IS A CONTROLLED DOCUMENT FOR AMP INCORPORATED. IT IS SUBJECT TO CHANGE AND THE CONTROLLING ENGINEERING ORGANIZATION SHOULD BE CONTACTED FOR THE LATEST REVISION.	MATERIAL		APPLICATION SPEC 114-2157	SIZE A3	CAGE CODE 00779	DRAWING NO C-51863	RESTRICTED TO -	
					WEIGHT -	CUSTOMER DRAWING		SCALE NTS	SHEET 2 OF 2	REV AA2

单击下面可查看定价，库存，交付和生命周期等信息

[>>TE Connectivity\(泰科\)](#)