

THIS DRAWING IS UNPUBLISHED.

RELEASED FOR PUBLICATION

© COPYRIGHT - By -

ALL RIGHTS RESERVED.

LOC GE DIST 00

REVISIONS

P	LTR	DESCRIPTION	DATE	DWN	APVD
	E2	REVISED PER ECO-11-018894	20SEP2011	DLD	LLV

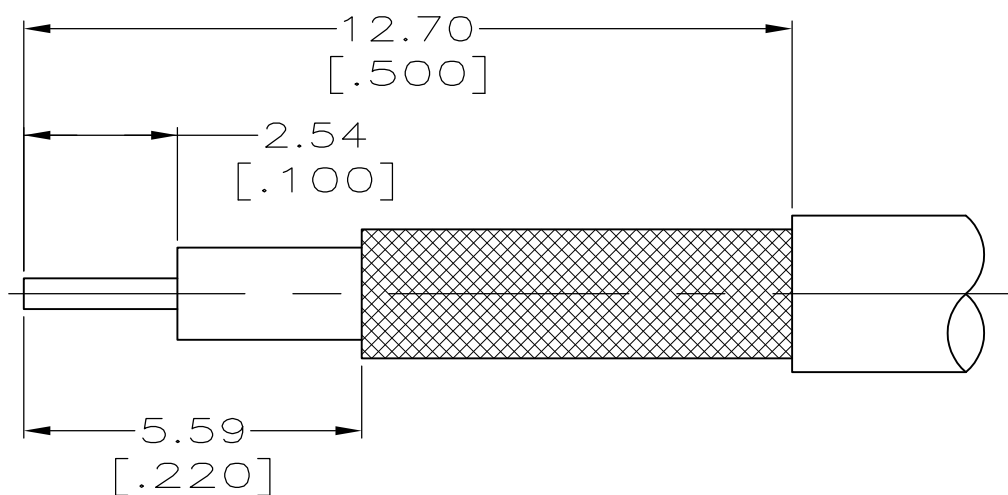

- 1 CRIMP CONTACT USING MIL HAND TOOL M22520/2-01 WITH DANIELS POSITIONER K1041, SET AT POSITION NUMBER 4.
- 2 CRIMP CABLE BRAID USING MIL HAND TOOL M22520/5-01 WITH DANIELS DIE SET Y-1637 (.128 INCH HEX) OR USE AMP PRO-CRIMPER II WITH DIE SET NUMBER 58483-1.

RECOMMENDED STRIP LENGTHS

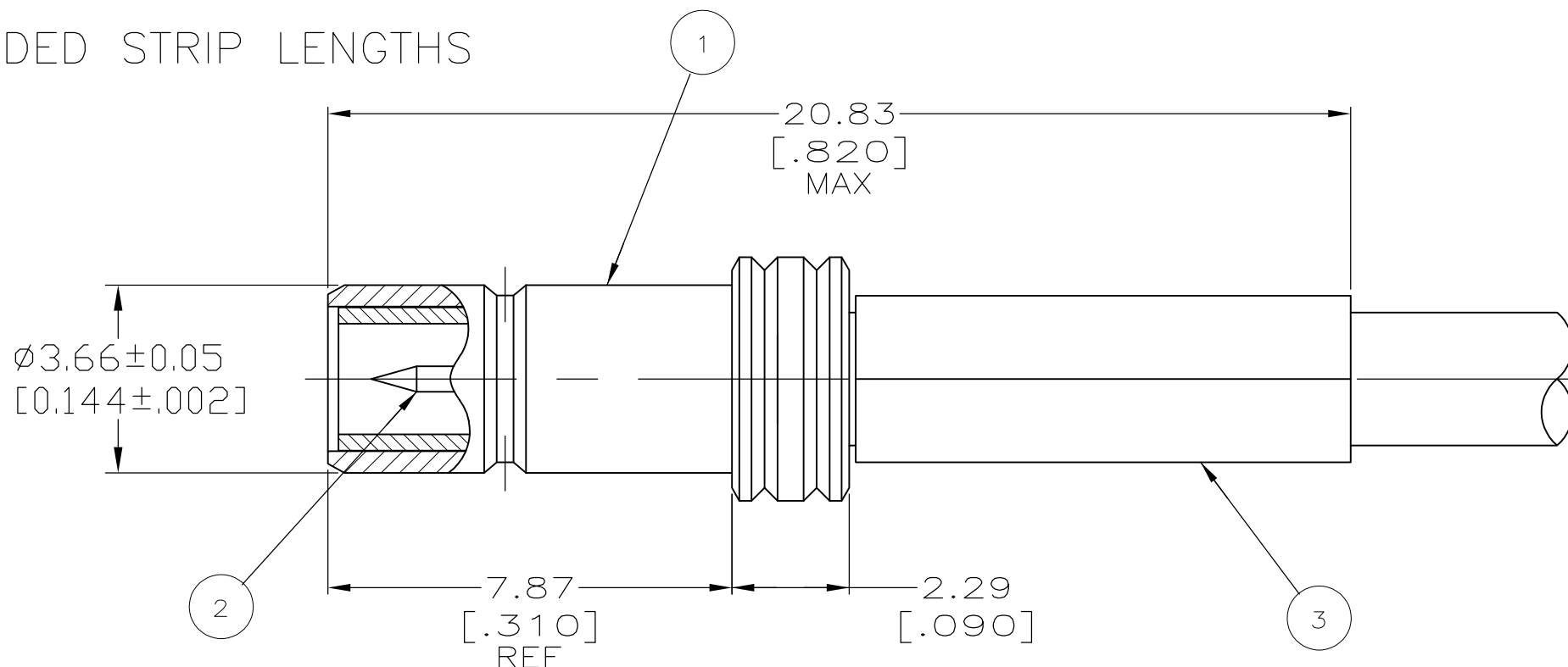

FOR PREVIOUS REV HISTORY, SEE DRAWING 414948

2	1	RG-188, -316, & 174/U	1-413889-3	414187-2	1326387-1	414948-1
BRAID CRIMP	CONTACT CRIMP	USE WITH CABLE	3 FERRULE QTY=1	2 CONTACT QTY=1	1 JACK ASSY QTY=1	PART NUMBER

THIS DRAWING IS A CONTROLLED DOCUMENT.

DIMENSIONS:
mm [INCHES]

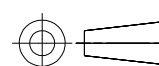

TOLERANCES UNLESS OTHERWISE SPECIFIED:	
0 PLC	± -
1 PLC	± -
2 PLC	± 0.25 [.010]
3 PLC	± -
4 PLC	± -
ANGLES	± -
FINISH	-

MATERIAL

-

DWN	P. COLLINS	22AUG00
CHK	J. CANOY	22AUG00
APVD	J. CANOY	22AUG00
PRODUCT SPEC	108-1401	
APPLICATION SPEC	114-13024	
WEIGHT	-	
CUSTOMER DRAWING		



NAME				CABLE JACK, STRAIGHT, 50 OHM, SMB	
SIZE	CAGE CODE	DRAWING NO	RESTRICTED TO		
A3	00779	C-414948-1	-		
SCALE		SHEET	REV		
8:1		1 OF 1	E2		

单击下面可查看定价，库存，交付和生命周期等信息

[>>TE Connectivity\(泰科\)](#)