

THIS DRAWING IS UNPUBLISHED. RELEASED FOR PUBLICATION  
 © COPYRIGHT - By - ALL RIGHTS RESERVED.

LOC		DIST		REVISIONS			
P	LTR	DESCRIPTION	DATE	DWN	APVD		
	J	REV PER ECO 14-014240	10-1-14	CT	CD		

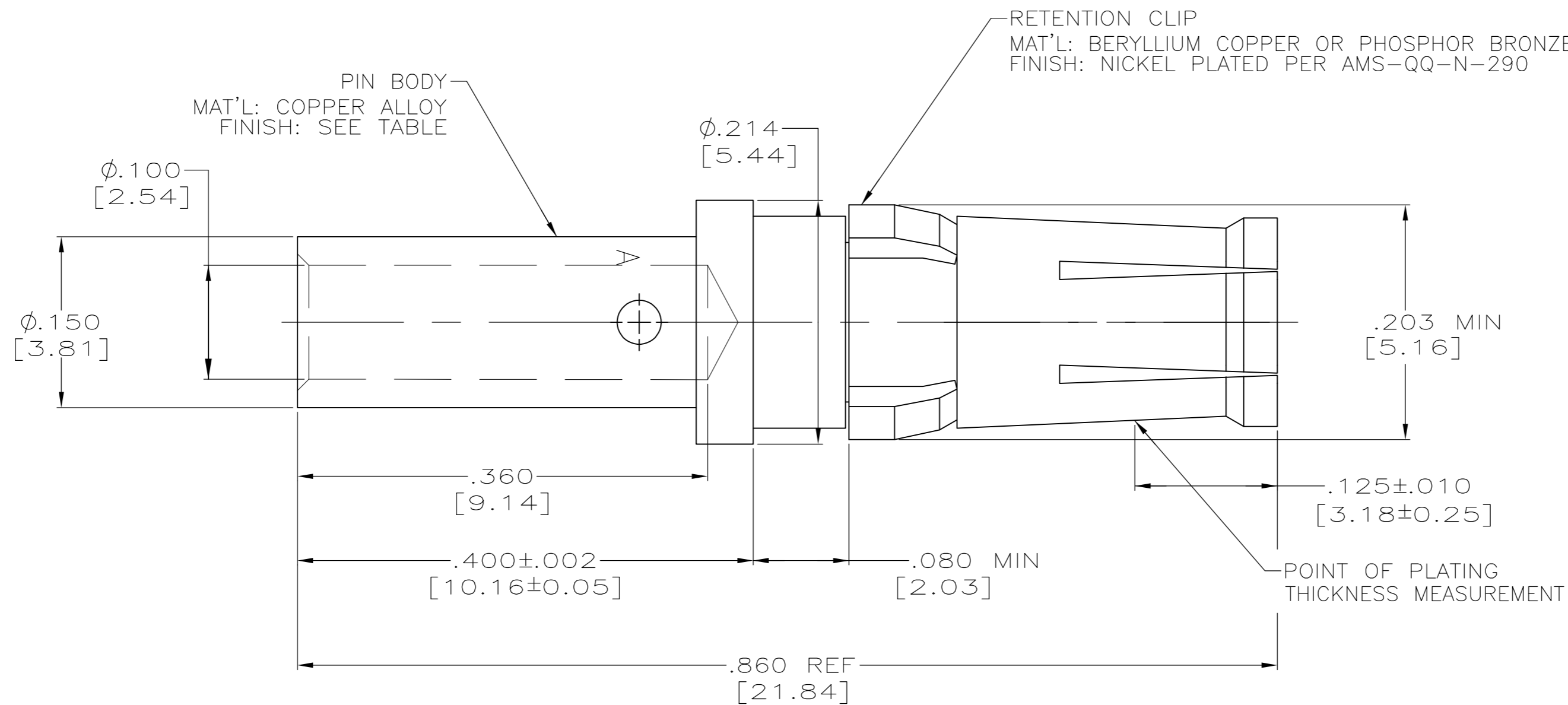

- THIS PART CONFORMS TO REQUIREMENTS FOR DANIELS CRIMP TOOL NO. M300-BT, WITH DANIELS POSITIONER PART NO. SP689, STRIP LENGTH .375, SETTING #1.
- MATES WITH 212007-1 IN AMPLIMITE CONNECTOR ASSEMBLIES ONLY.
- FINISH: PLATED GOLD .000050 [0.00127] MIN THK PER ASTM-B0488 OVER NICKEL .000050 [0.00127] MIN THK PER AMS-QQ-N-290.
- FINISH: PLATED GOLD .000030 [0.00076] MIN THK PER ASTM-B0488 OVER NICKEL .000050 [0.00127] MIN THK PER AMS-QQ-N-290.
- WIRE BARREL WILL ACCEPT #12-#14 AWG WIRE.
- RESTRICTED PART NUMBER.

PRELIMINARY NOT RELEASED FOR PRODUCTION	6	1-212008-1
	4	212008-2
	3	212008-1
	FINISH	PART NUMBER

THIS DRAWING IS A CONTROLLED DOCUMENT.		DWN	C.C.THOMAS	11/10/00	 TE Connectivity	
DIMENSIONS: INCHES[MM]		CHK	D.MILLER	11/10/00		
TOLERANCES UNLESS OTHERWISE SPECIFIED:		APVD	D.MILLER	11/10/00		
0 PLC ± - 1 PLC ± - 2 PLC ± - 3 PLC ± .005 [0.13] 4 PLC ± - ANGLES ± - FINISH SEE TABLE		PRODUCT SPEC	108-10045			
MATERIAL SEE CALLOUTS		APPLICATION SPEC	114-10014		NAME	ASSEMBLY, SOCKET CONTACT POWER VIII, 12 & 4 AWG
		WEIGHT	-		SIZE	A2
		CUSTOMER DRAWING	SCALE	10:1	CAGE CODE	00779
			SHEET	1 of 1	DRAWING NO	C-212008
			REV	J	RESTRICTED TO	-

单击下面可查看定价，库存，交付和生命周期等信息

[>>TE Connectivity\(泰科\)](#)