

THIS DRAWING IS UNPUBLISHED. RELEASED FOR PUBLICATION 20
 © COPYRIGHT 20 BY - ALL RIGHTS RESERVED.

REVISIONS				
P	LTR	DESCRIPTION	DATE	APVD
A		PRODUCTION RELEASE	13JUN2019	JW SH

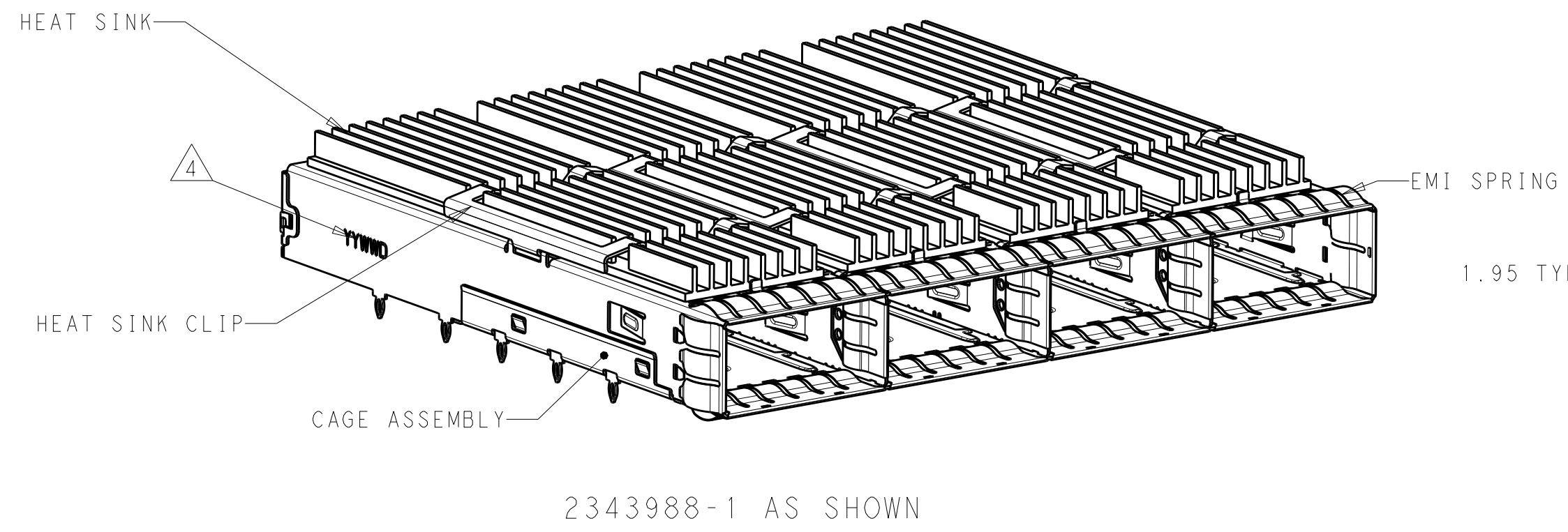

2343988-1 AS SHOWN

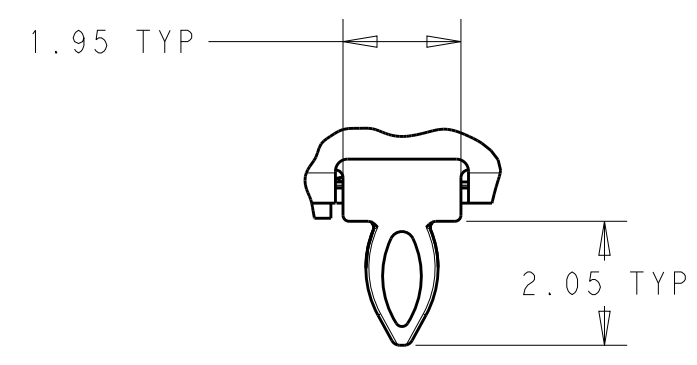

DETAIL A
SCALE 8:1

- 1 CAGE ASSEMBLY: STAINLESS STEEL.
HEAT SINK: ALUMINUM/BLACK ANODIZE.
HEAT SINK CLIP: STAINLESS STEEL.
EMI SPRING: COPPER ALLOY/NICKEL PLATE.
- 2 REFERENCE APPLICATION SPECIFICATION 114-32023 FOR RECOMMENDED DRILL HOLE DIAMETER AND PLATING THICKNESS. BOARD LAYOUT PER THIS PRINT.
- 3 DATUM AND BASIC DIMENSION ESTABLISHED BY CUSTOMER.
- 4 DATE CODE (YYWW) MARKED APPROXIMATELY AS SHOWN.
- 5. MATES WITH QSFP DD MSA COMPATIBLE TRANSCEIVER.
- 6. MINIMUM PC BOARD THICKNESS: SINGLE SIDED: 1.45 MIN
DOUBLE SIDED: 2.20 MIN
- 7 ONLY FOR VERSION WITH REAR EONS

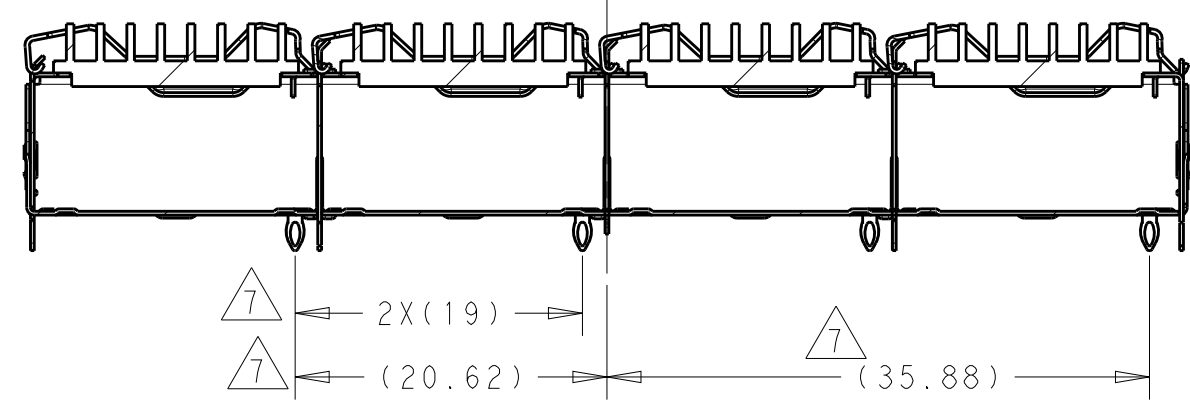
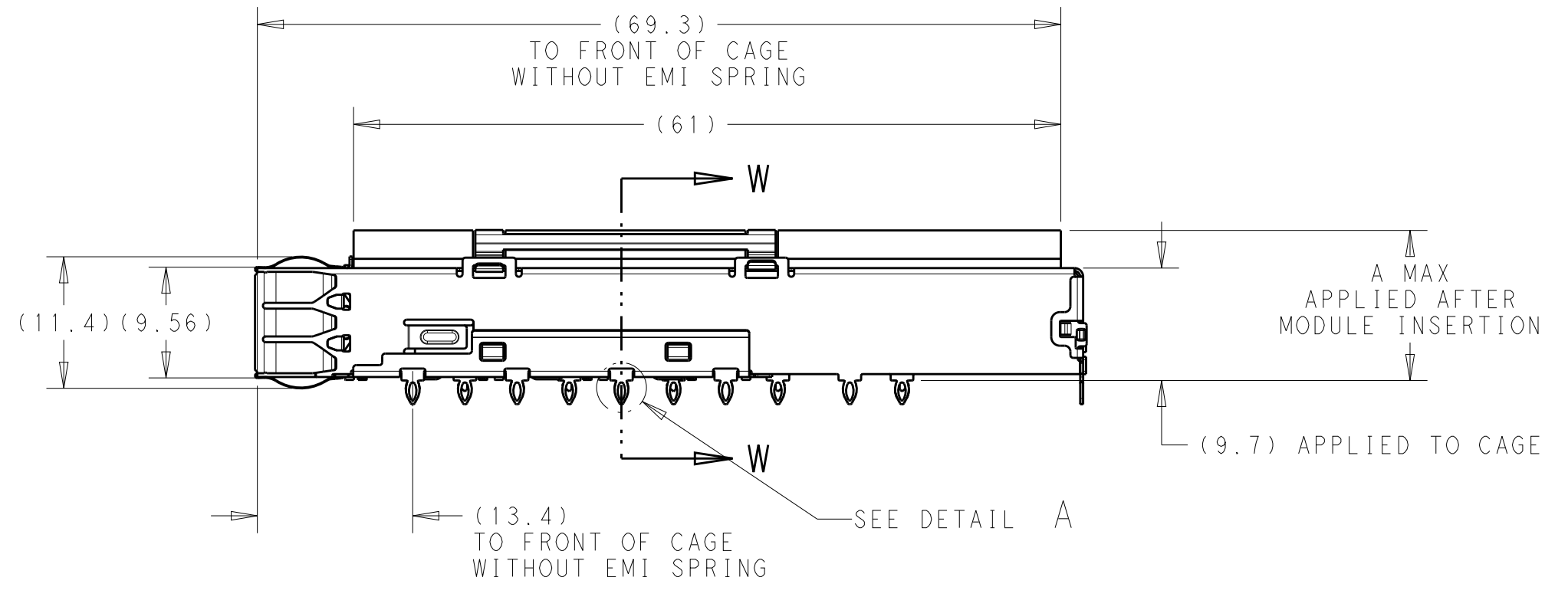
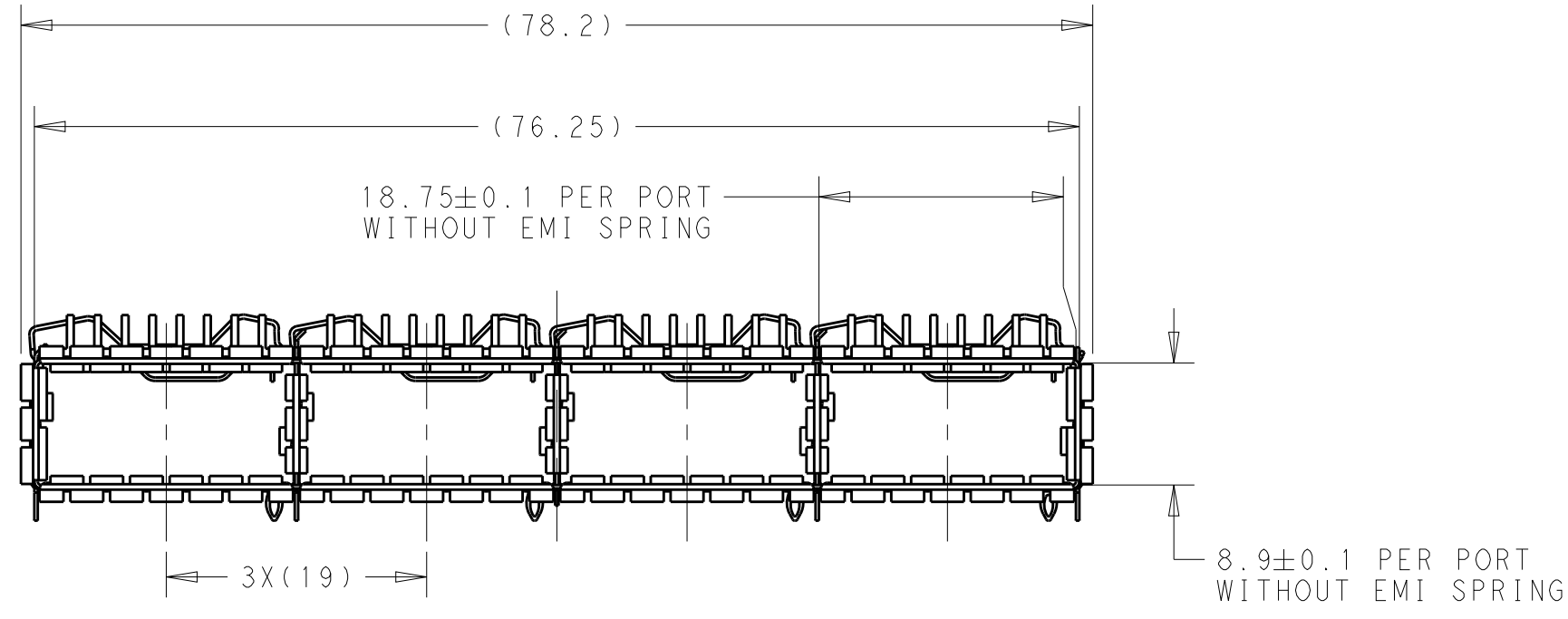

For 2343988-1/-2-3 WITH REAR EONS
SECTION W-W

VERSION	DIM A	PART NUMBER
W/O REAR EONS	23	1-2343988-3
W/O REAR EONS	16	1-2343988-2
W/O REAR EONS	13.7	1-2343988-1
W REAR EONS	23	2343988-3
W REAR EONS	16	2343988-2
W REAR EONS	13.7	2343988-1

THIS DRAWING IS A CONTROLLED DOCUMENT.		DWN J. WANG 10OCT2018	TE Connectivity	
DIMENSIONS: mm		CHK S. HAN 10OCT2018		
TOLERANCES UNLESS OTHERWISE SPECIFIED:		APVD S. HAN 10OCT2018	NAME CAGE WITH HEATSINK THRU BEZEL, 1X4, QSFP DD	
0 PLC ±0.25	1 PLC ±0.25	PRODUCT SPEC	SIZE CAGE CODE DRAWING NO RESTRICTED TO	
2 PLC ±0.25	3 PLC ±	APPLICATION SPEC	A2 - C-2343988	
4 PLC ±	ANGLES ±	WEIGHT	SCALE 1:1 SHEET 1 OF 6 REV A	
FINISH		CUSTOMER DRAWING		

THIS DRAWING IS UNPUBLISHED. RELEASED FOR PUBLICATION 20
 © COPYRIGHT 20 BY - ALL RIGHTS RESERVED.

REVISIONS					
P	LTR	DESCRIPTION	DATE	DWN	APVD
-		SEE SHEET 1	-	-	-

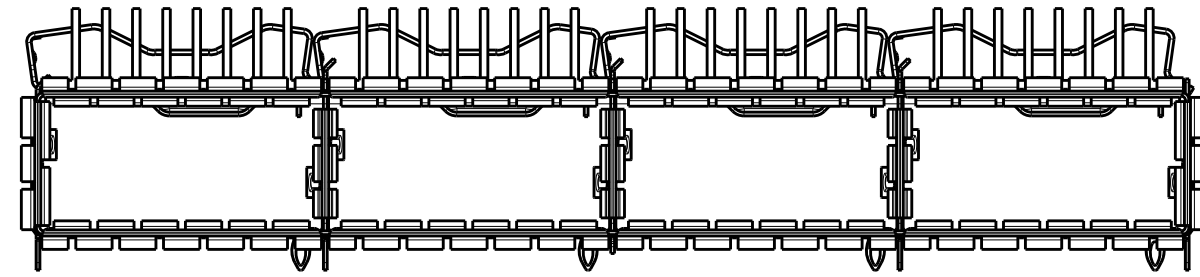

2343988-2
 UNMARKED DIMENSIONS SAME AS 2343988-1
 SCALE 2:1

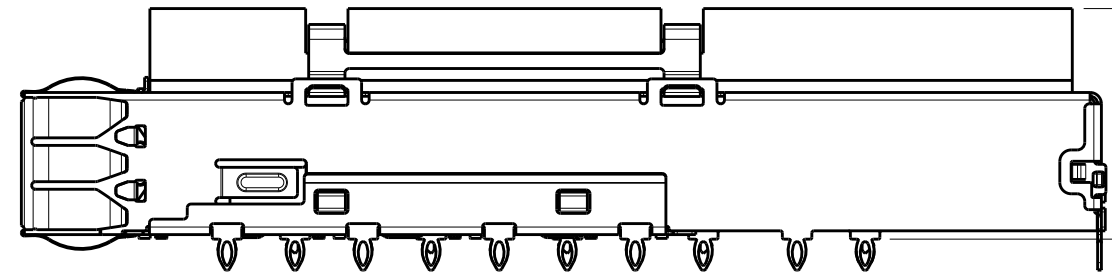

A MAX
 AFTER MODULE
 INSERTION

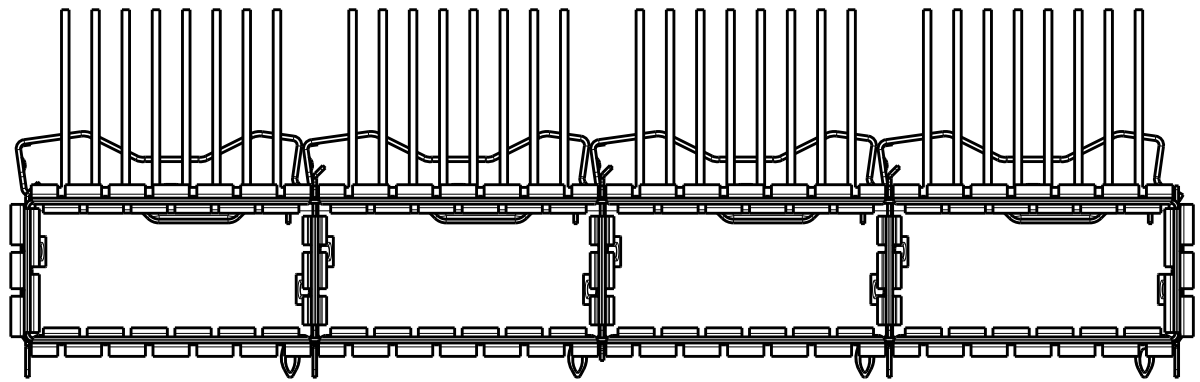
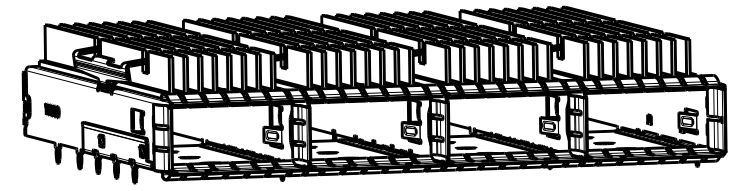

2343988-3
 UNMARKED DIMENSIONS SAME AS 2343988-1
 SCALE 2:1

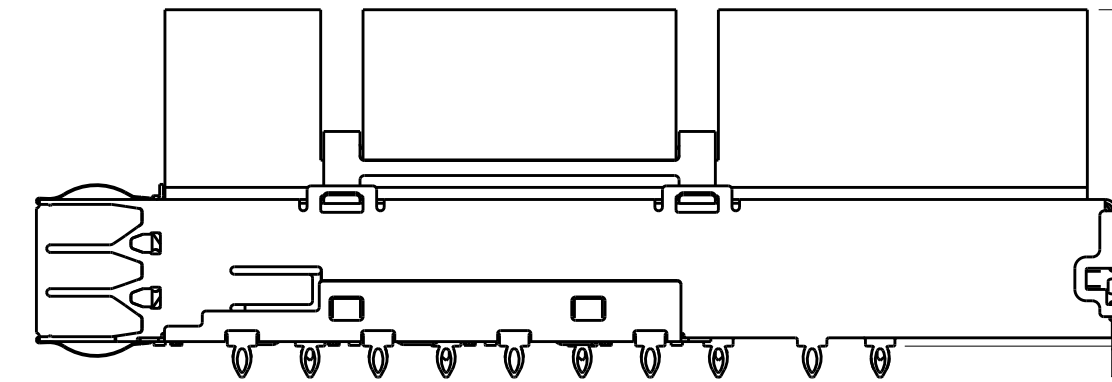

AMAX
 AFTER MODULE
 INSERTION

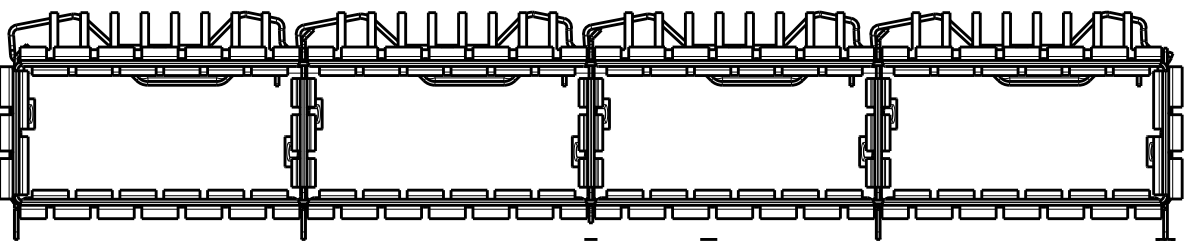
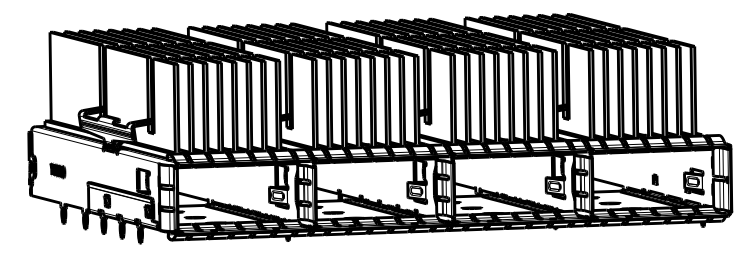

1-2343988-1
 WITHOUT REAR EONS
 UNMARKED DIMENSIONS SAME AS 2343988-1
 SCALE 2:1

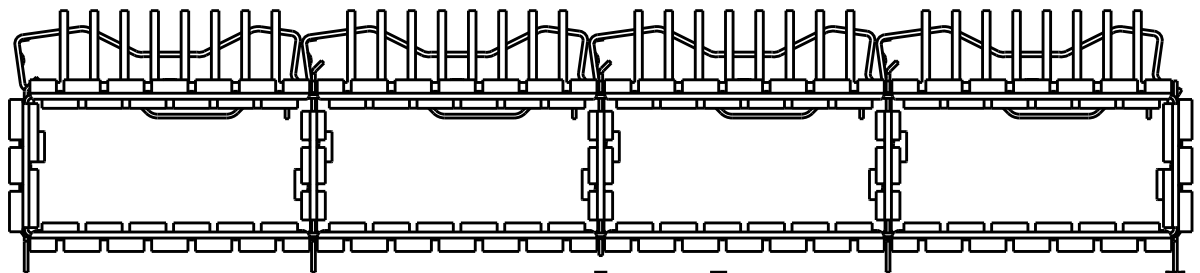
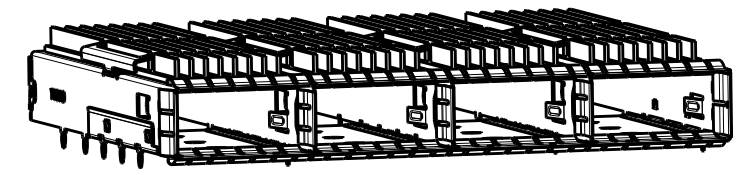
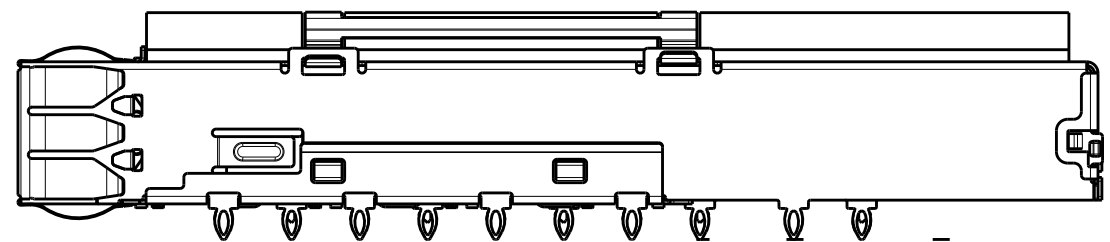

1-2343988-2
 WITHOUT REAR EONS
 UNMARKED DIMENSIONS SAME AS 2343988-2
 SCALE 2:1

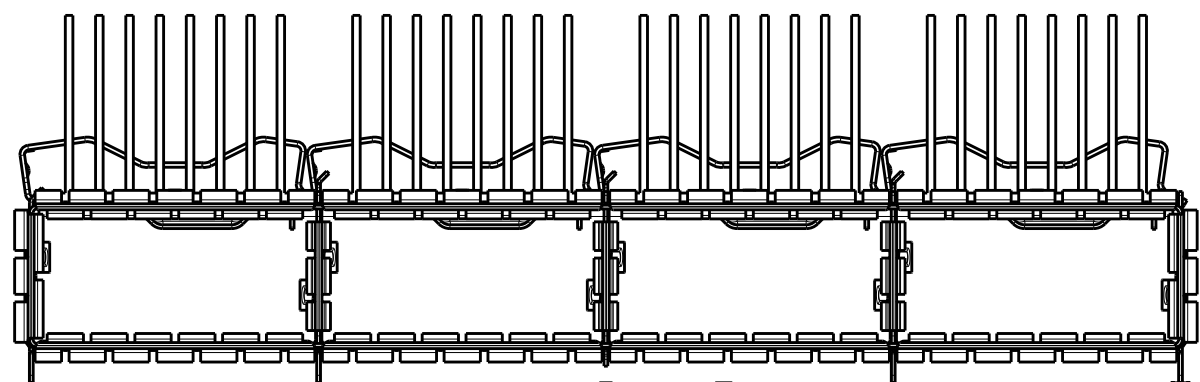
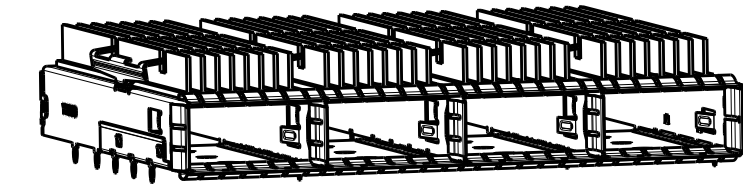
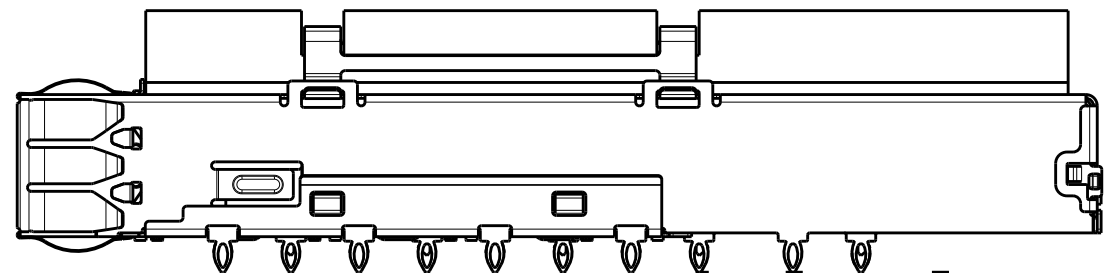

1-2343988-3
 WITHOUT REAR EONS
 UNMARKED DIMENSIONS SAME AS 2343988-3
 SCALE 2:1

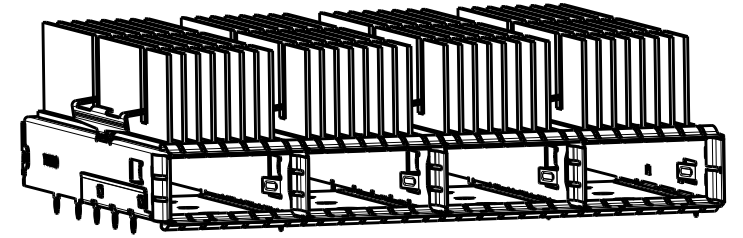
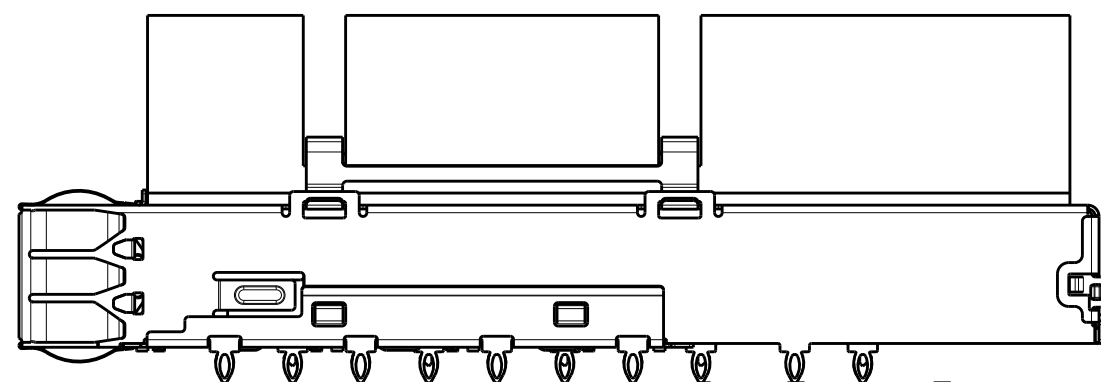

THIS DRAWING IS A CONTROLLED DOCUMENT.		DWN J. WANG 10OCT2018	TE Connectivity	
DIMENSIONS:		CHK S. HAN 10OCT2018		
mm	TOLERANCES UNLESS OTHERWISE SPECIFIED:	APVD S. HAN 10OCT2018	NAME CAGE WITH HEATSINK THRU BEZEL, 1X4, QSFP DD	
0 PLC	±0.25	PRODUCT SPEC	SIZE CAGE CODE DRAWING NO RESTRICTED TO	
1 PLC	±0.25	APPLICATION SPEC	A2	-
2 PLC	±0.25	WEIGHT	G-2343988	
3 PLC	±	CUSTOMER DRAWING	SCALE 1:1	SHEET 2 OF 6
4 PLC	±			REV A
ANGLES	±			
FINISH	-			

THIS DRAWING IS UNPUBLISHED. RELEASED FOR PUBLICATION 20
 © COPYRIGHT 20 BY - ALL RIGHTS RESERVED.

REVISIONS				
P	LTR	DESCRIPTION	DATE	APVD
-	-	SEE SHEET 1	-	-

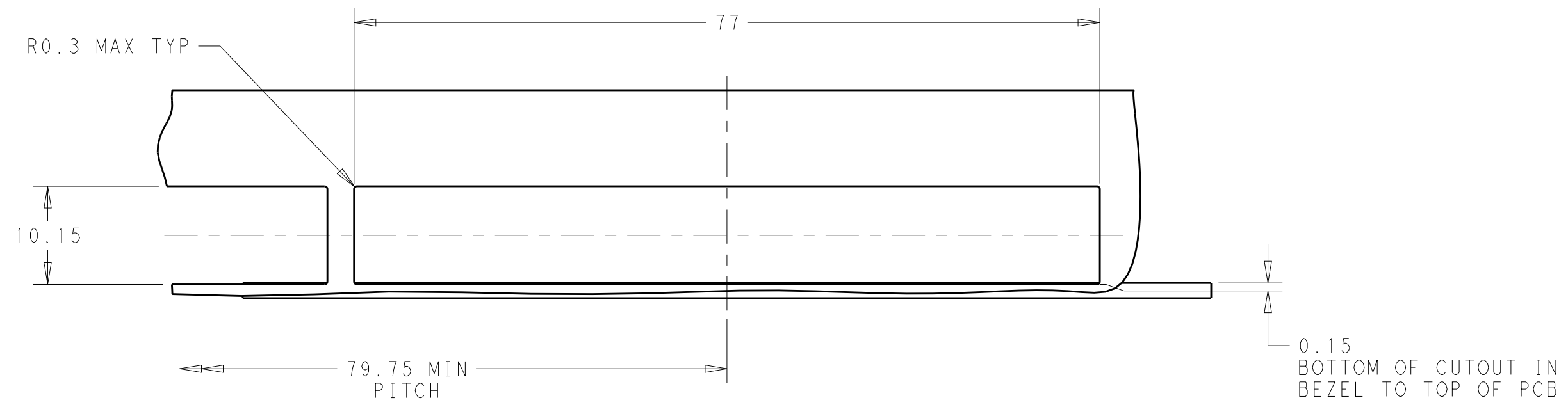

CAGE ASSEMBLY OMITTED FOR CLARITY

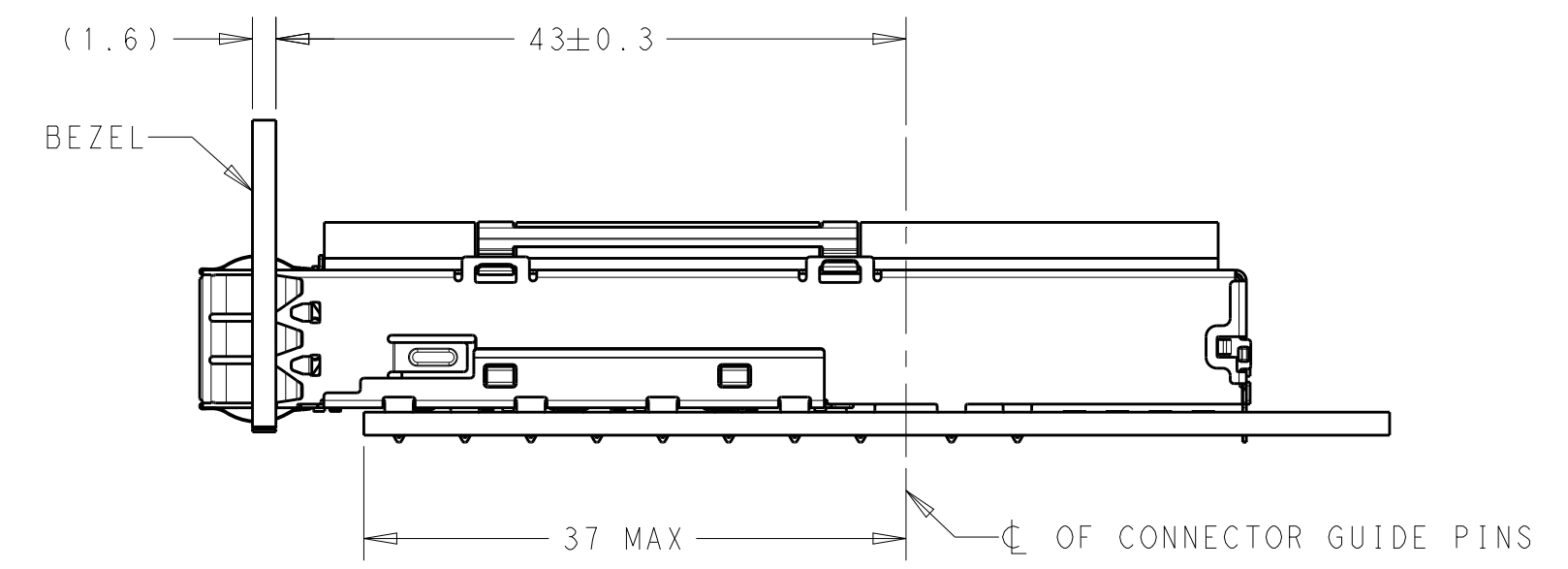

SINGLE SIDE MOUNTING

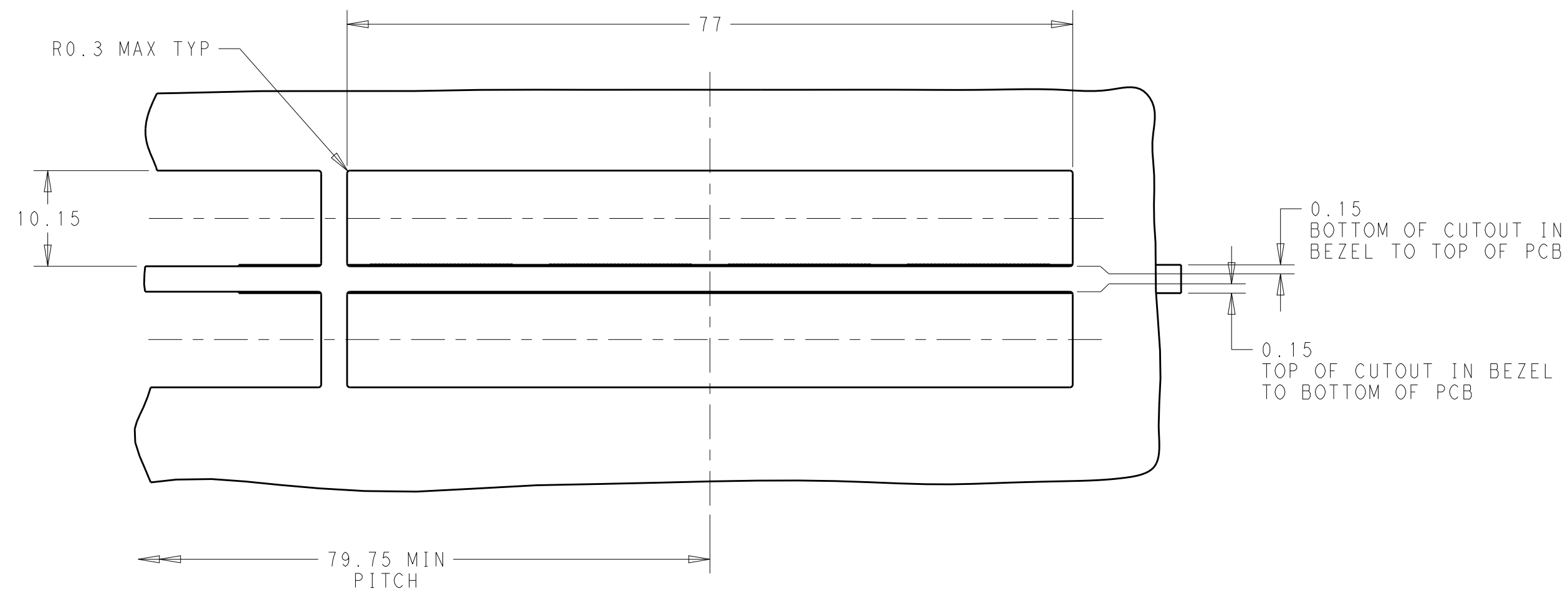

CAGE ASSEMBLY OMITTED FOR CLARITY

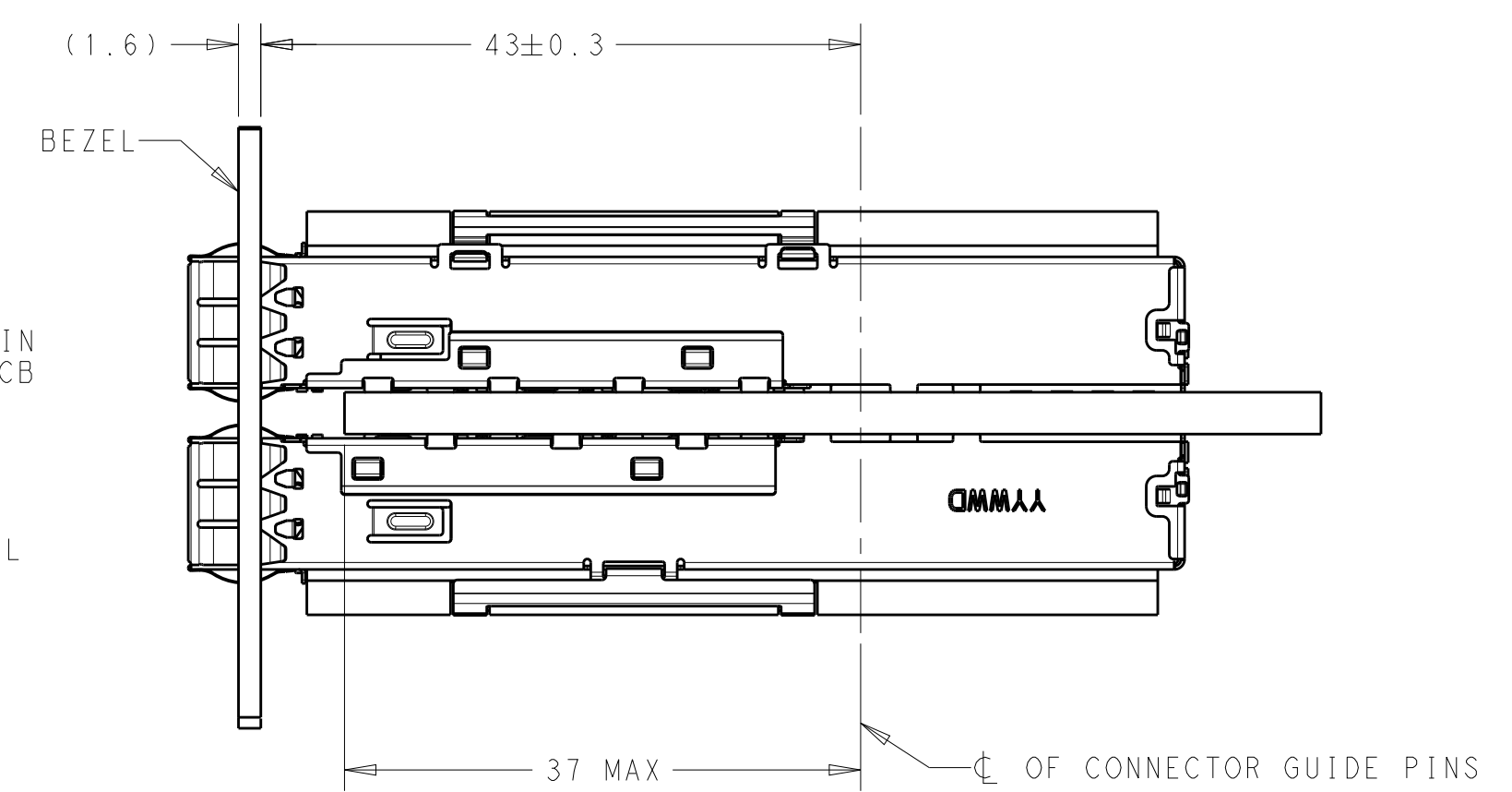

BELLY TO BELLY MOUNTING

THIS DRAWING IS A CONTROLLED DOCUMENT.		DWN J. WANG 10OCT2018	TE Connectivity	
DIMENSIONS: mm		CHK S. HAN 10OCT2018		
TOLERANCES UNLESS OTHERWISE SPECIFIED:		APVD S. HAN 10OCT2018	NAME CAGE WITH HEATSINK THRU BEZEL, 1X4, QSFP DD	
0 PLC ±0.25 1 PLC ±0.25 2 PLC ±0.25 3 PLC ± 4 PLC ± ANGLES ± FINISH ±		PRODUCT SPEC -	SIZE A2	CAGE CODE -
MATERIAL -		APPLICATION SPEC -	DRAWING NO C-2343988	RESTRICTED TO -
-		WEIGHT -	SCALE 1:1	SHEET 3 OF 6
-		CUSTOMER DRAWING	REV A	

THIS DRAWING IS UNPUBLISHED. RELEASED FOR PUBLICATION 20
 © COPYRIGHT 20 BY - ALL RIGHTS RESERVED.

REVISIONS				
P	LTR	DESCRIPTION	DATE	APVD
-	-	SEE SHEET 1	-	-

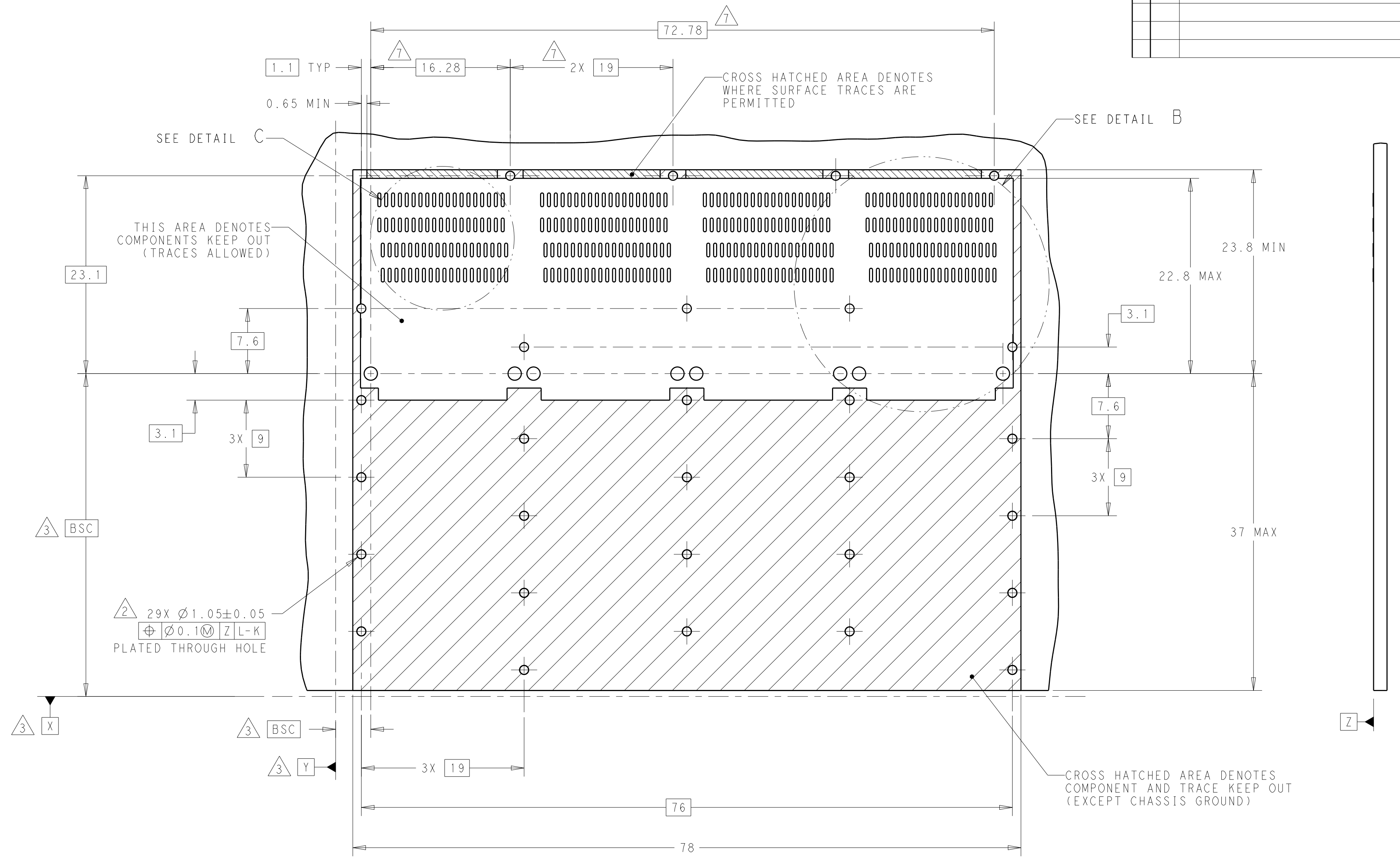

RECOMMENDED PCB LAYOUT
 SINGLE TYPE
 SCALE 3:1

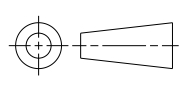
THIS DRAWING IS A CONTROLLED DOCUMENT.		DWN J. WANG 10OCT2018	 TE Connectivity
DIMENSIONS: mm		CHK S. HAN 10OCT2018	
		APVD S. HAN 10OCT2018	
TOLERANCES UNLESS OTHERWISE SPECIFIED:		PRODUCT SPEC	NAME CAGE WITH HEATSINK THRU BEZEL, 1X4, QSFP DD
0 PLC	±0.25	APPLICATION SPEC	SIZE A2
1 PLC	±0.25	WEIGHT	CAGE CODE -
2 PLC	±0.25	CUSTOMER DRAWING	DRAWING NO C-2343988
3 PLC	±	SCALE 1:1	RESTRICTED TO -
4 PLC	±	SCALE 1:1	SHEET 4 OF 6
ANGLES	±	SCALE 1:1	REV A
FINISH	-	SCALE 1:1	REV A

THIS DRAWING IS UNPUBLISHED. RELEASED FOR PUBLICATION 20
 © COPYRIGHT 20 BY - ALL RIGHTS RESERVED.

REVISIONS				
P	LTR	DESCRIPTION	DATE	APVD
-	-	SEE SHEET 1	-	-

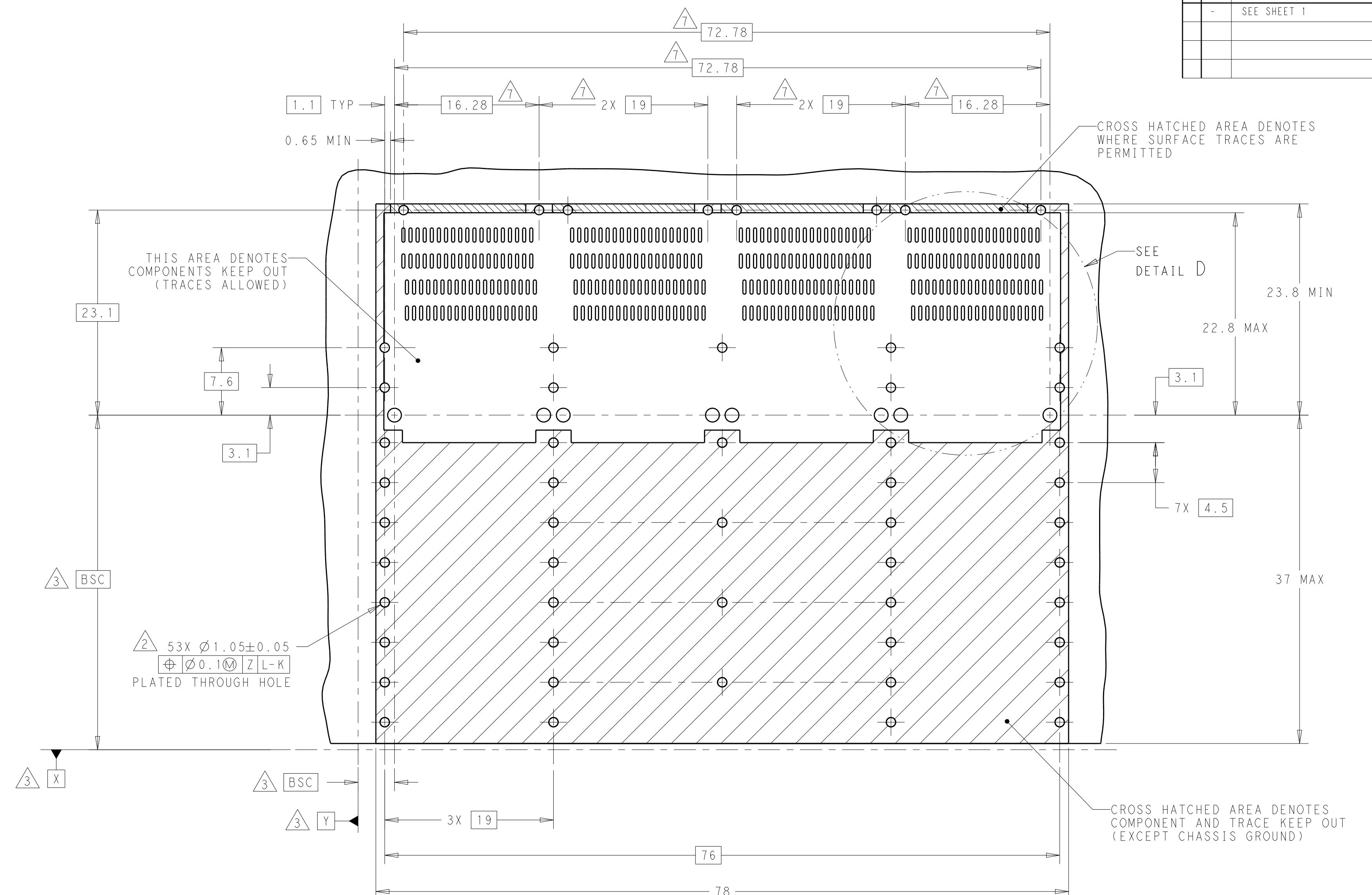

RECOMMENDED PCB LAYOUT
 BELLY TO BELLY
 SCALE 3:1

THIS DRAWING IS A CONTROLLED DOCUMENT.		DWN J. WANG 10OCT2018	TE Connectivity	
DIMENSIONS: mm		CHK S. HAN 10OCT2018		
TOLERANCES UNLESS OTHERWISE SPECIFIED:		APVD S. HAN 10OCT2018	NAME CAGE WITH HEATSINK THRU BEZEL, 1X4, QSFP DD	
0 PLC ±0.25	1 PLC ±0.25	PRODUCT SPEC	SIZE A2	
2 PLC ±0.25	3 PLC ±	APPLICATION SPEC	CAGE CODE	DRAWING NO
4 PLC ±	ANGLES ±	WEIGHT	C-2343988	RESTRICTED TO
MATERIAL	FINISH	CUSTOMER DRAWING	SCALE 2:1	SHEET 5 OF 6

THIS DRAWING IS UNPUBLISHED. RELEASED FOR PUBLICATION 20
 © COPYRIGHT 20 BY - ALL RIGHTS RESERVED.

REVISIONS				
P	LTR	DESCRIPTION	DATE	APVD
-	-	SEE SHEET 1	-	-

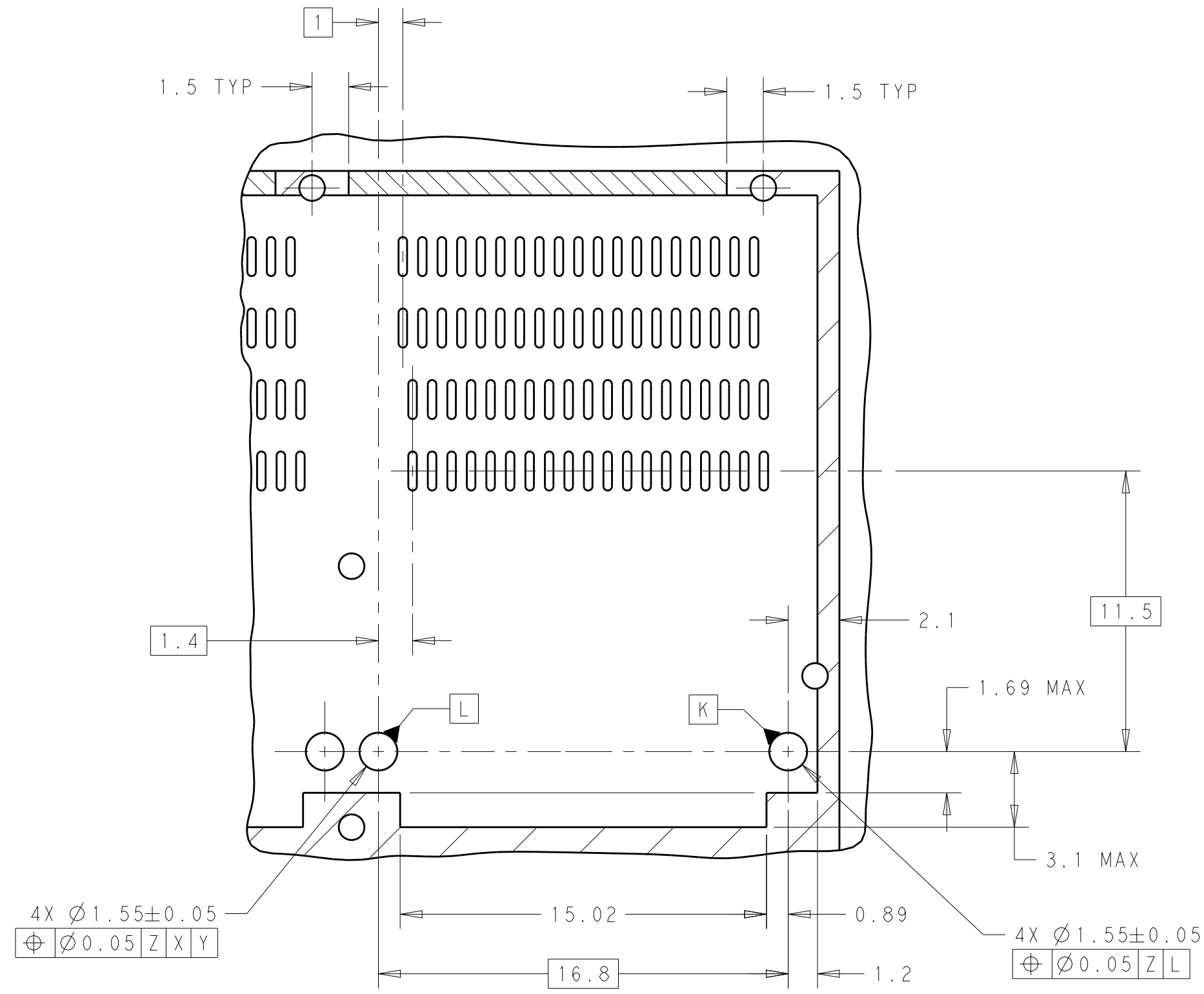

DETAIL B
 SCALE 5:1

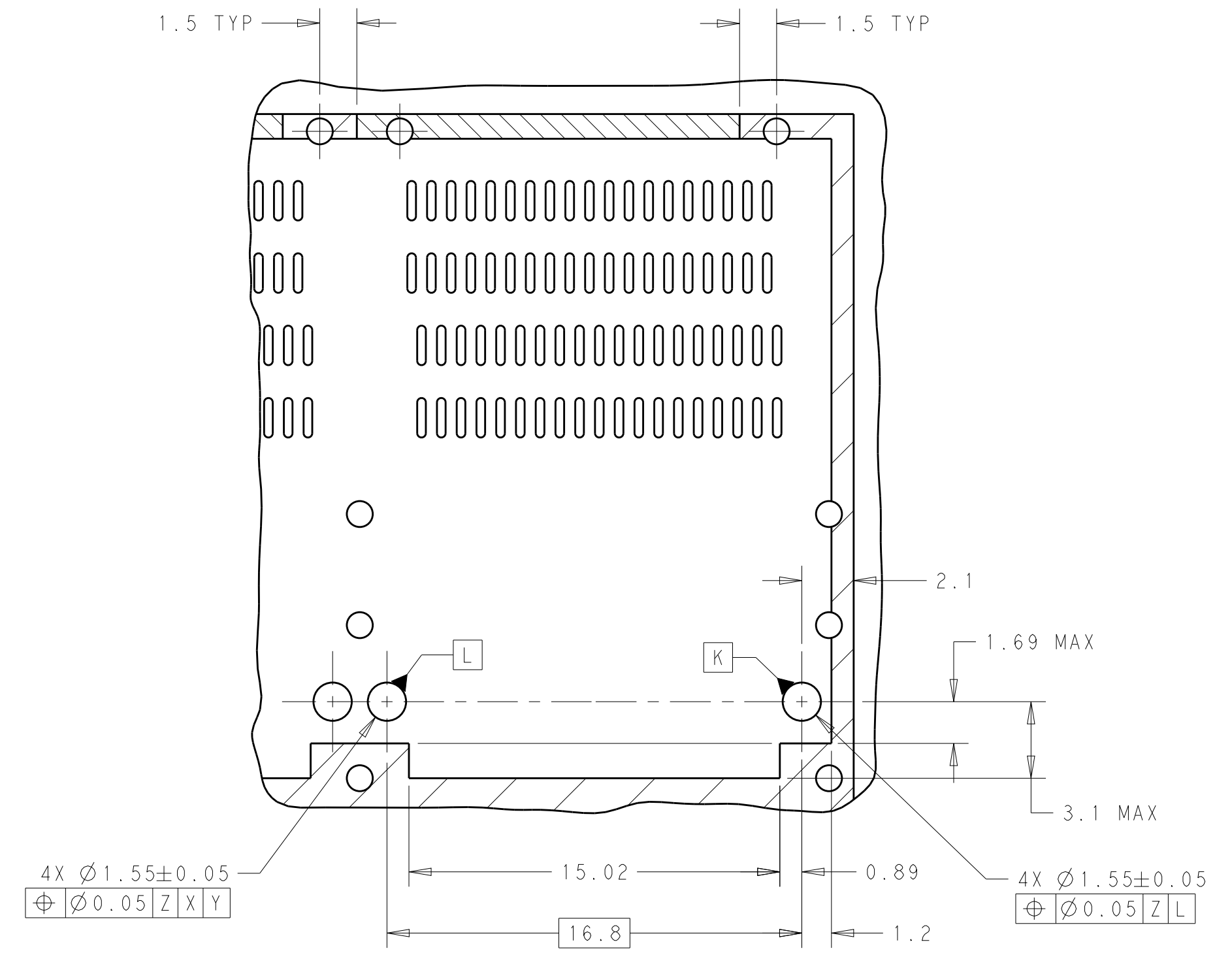

DETAIL D
 SCALE 5:1

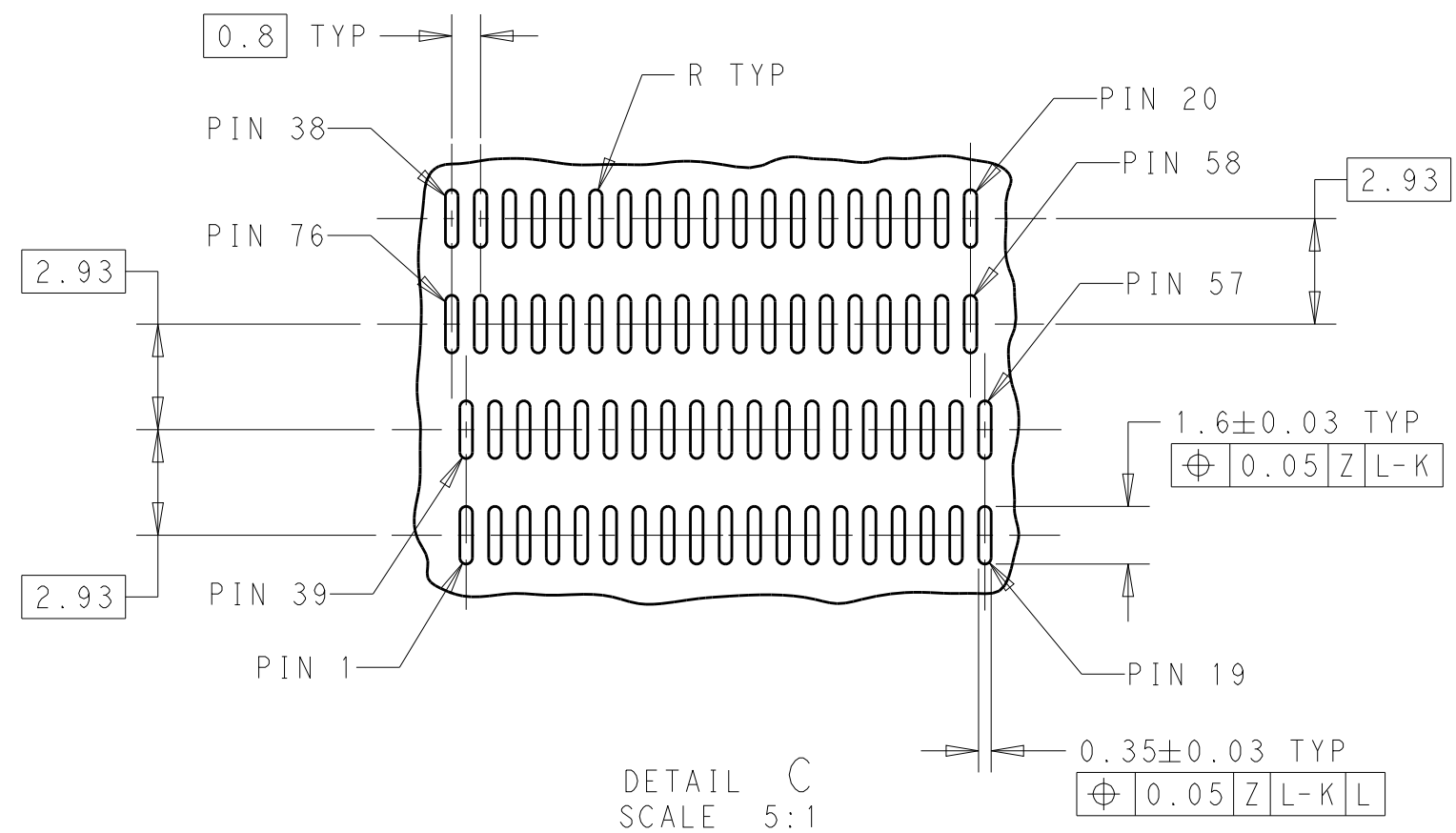

DETAIL C
 SCALE 5:1

THIS DRAWING IS A CONTROLLED DOCUMENT.		DWN J. WANG 10OCT2018	TE Connectivity	
DIMENSIONS: mm		CHK S. HAN 10OCT2018		
TOLERANCES UNLESS OTHERWISE SPECIFIED:		APVD S. HAN 10OCT2018	NAME CAGE WITH HEATSINK THRU BEZEL, 1X4, QSFP DD	
0 PLC ±0.25		PRODUCT SPEC	SIZE A2	
1 PLC ±0.25		APPLICATION SPEC	CAGE CODE -	
2 PLC ±0.25		WEIGHT	DRAWING NO C-2343988	
3 PLC ±		CUSTOMER DRAWING	RESTRICTED TO -	
4 PLC ±		SCALE 2:1	SHEET 6 OF 6	
ANGLES ±		REV A		
FINISH ±				

单击下面可查看定价，库存，交付和生命周期等信息

[>>TE Connectivity\(泰科\)](#)