

THIS DRAWING IS UNPUBLISHED. RELEASED FOR PUBLICATION  
 © COPYRIGHT - BY TYCO ELECTRONICS CORPORATION. ALL RIGHTS RESERVED.

LOC	DIST	REVISIONS					
		P	LTR	DESCRIPTION	DATE	DWN	APVD
AF	50		E1	ECR-06-023927(REDRAWN IN AUTOCAD)	17OCT06	HMR	GP

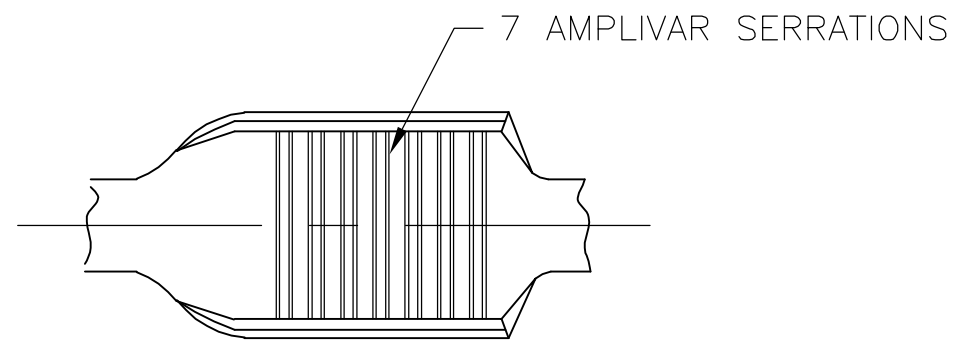

- CONTINUOUS STRIP ON REELS
- DIMENSIONS IN BRACKETS ARE IN INCHES
- FOR ADDITIONAL INFORMATION, SEE APPLICATION SPEC. 114-2002
- WIRE RANGE: 600-3000 CMA.
- CRIMP WIDTH: .110 F TYPE (AMPLIVAR PIGTAIL)  
 CRIMP HEIGHT (±.002)=(TOTAL CMA+9,400)/190,500  
 GENERAL APPLICATION GUIDELINES MUST BE FOLLOWED AS SPECIFIED IN CATALOG #82221  
 FOR APPLICATOR INFORMATION CALL:1-800-722-1111  
 FOR PRODUCT INFORMATION CALL:1-800-522-6752

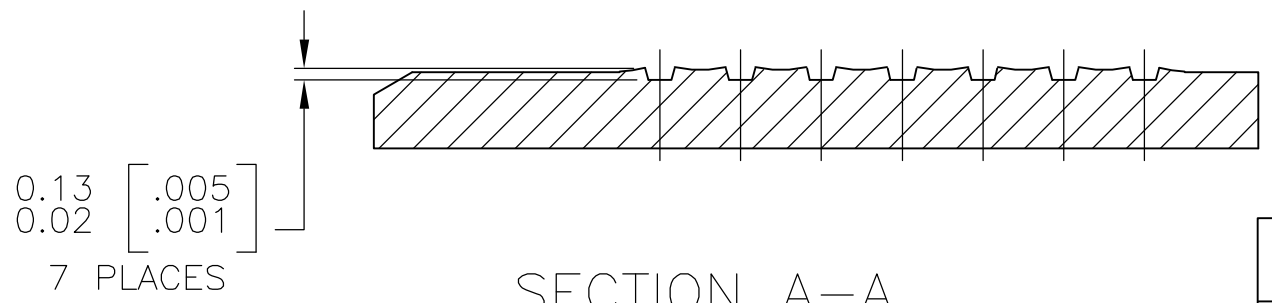
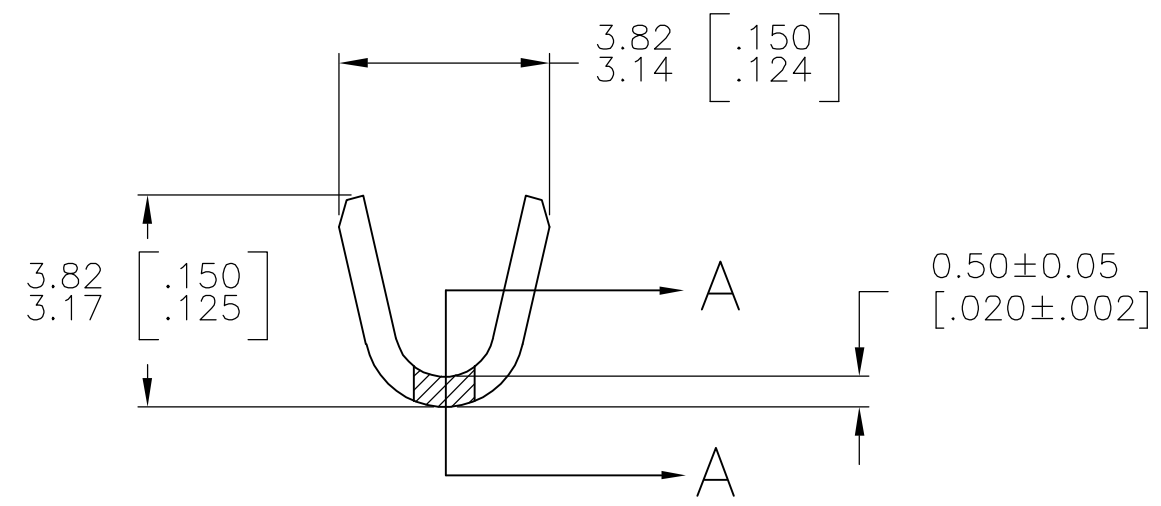
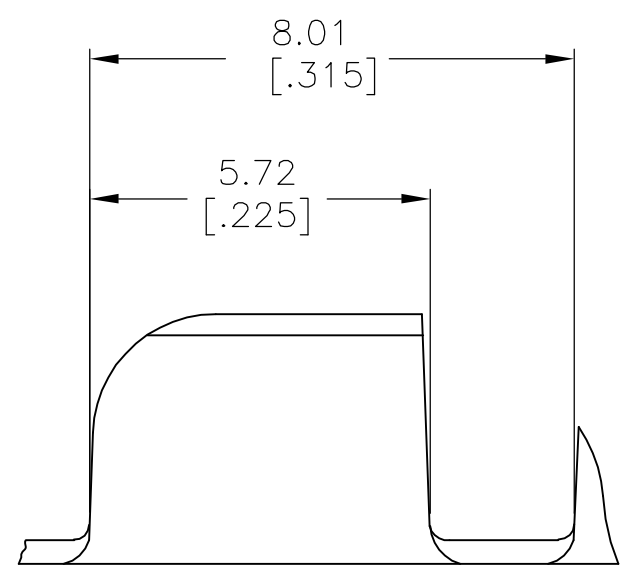

SECTION A-A  
SCALE 20:1

TIN PLATE	62157-2
-	62157-1
FINISH	PART NO

THIS DRAWING IS A CONTROLLED DOCUMENT.		DWN RAGHAVENDRA 17OCT2006	Tyco Electronics Corporation Harrisburg, PA 17105-3608	
DIMENSIONS: mm [INCHES]	TOLERANCES UNLESS OTHERWISE SPECIFIED:	CHK G.D.PORTA	NAME	
	0 PLC ± -	APVD G.D.PORTA	PRODUCT SPEC	
	1 PLC ± -	PRODUCT SPEC	APPLICATION SPEC	
	2 PLC ± -	SIZE	CAGE CODE	DRAWING NO
	3 PLC ± 0.38 [.015]	RESTRICTED TO	-	
	4 PLC ± -	WEIGHT	-	
	ANGLES ± 1' 0"	A3 00779 C-62157		
MATERIAL BRASS	FINISH SEE TABLE	CUSTOMER DRAWING		
		SCALE 8:1	SHEET 1 OF 1	REV E1

单击下面可查看定价，库存，交付和生命周期等信息

[>>TE Connectivity\(泰科\)](#)