

THIS DRAWING IS UNPUBLISHED. RELEASED FOR PUBLICATION
 © COPYRIGHT - By - ALL RIGHTS RESERVED.

REVISIONS					
P	LTR	DESCRIPTION	DATE	DWN	APVD
H		REVISED PER ECO-18-009360	15JUN2018	AP	DG

PART NUMBER	No. of Contact	A ±0.20	B ±0.20	C ±0.20	D
2301844-1	09	16.34	24.99	30.81	11.08

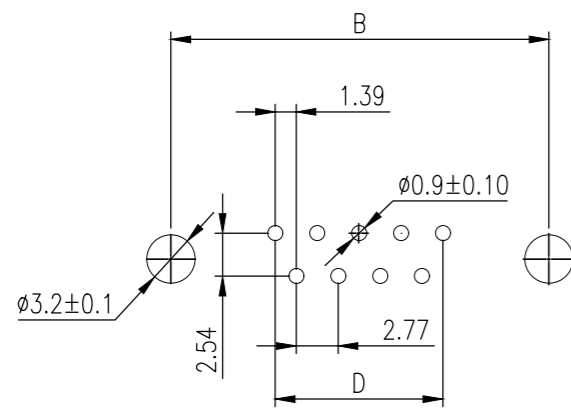
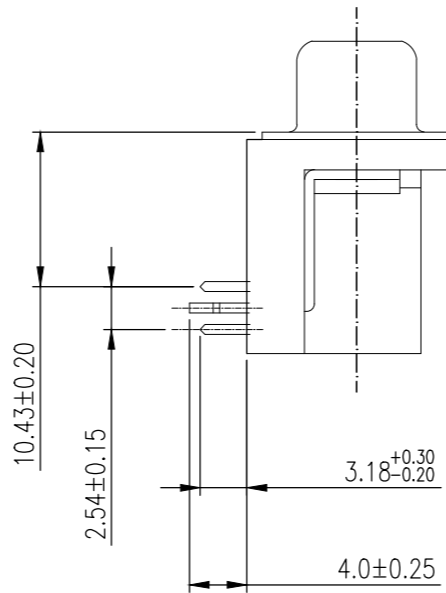
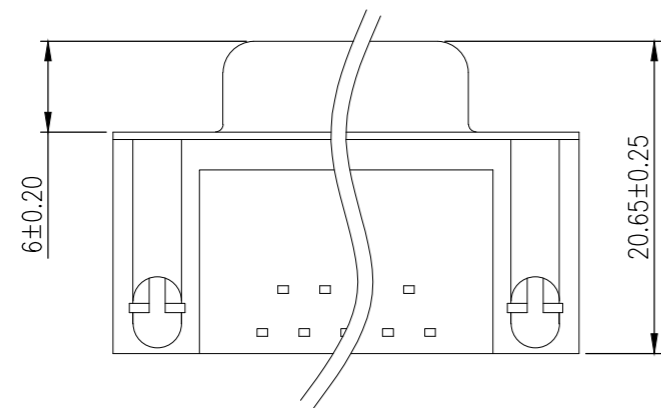
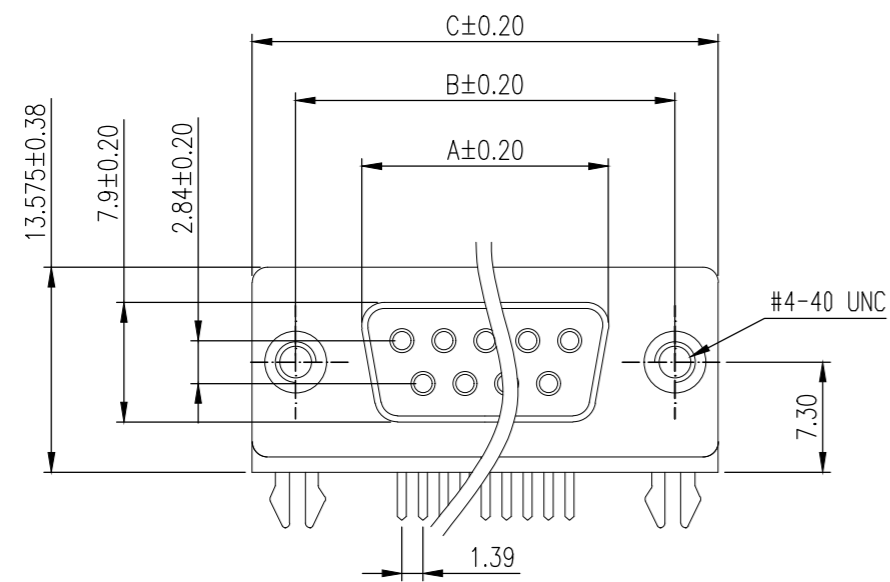

P.C.B LAYOUT

NOTE:

- MATERIAL:
 HOUSING: PBT WITH 20% GF UL 94 V-0, BLACK COLOR
 CONTACTS: PHOSPHOR BRONZE.
 SHELL: STEEL
 GROUNDING BRACKET: BRASS
 RIVETED INSERT: BRASS
 SCREWLOCK: BRASS
- FINISH:
 CONTACTS: 0.36 µm [15 µ"] GOLD IN CONTACT AREA.
 2.54 µm [100µ"] MATTE TIN ON SOLDER TAILS
 1.27 µm [50 µ"] NICKEL UNDERPLATE OVERALL
 SHELL: 2.54 µm [100µ"] NICKEL
 RIVET: 1.27 µm [50 µ"] NICKEL
 SCREWLOCK: 1.27 µm [50 µ"] NICKEL
 BOARDLOCK: 1.27µm [50µ"] MIN NICKEL UNDERPLATE.
 2.54µm [100µ"] MIN MATTE TIN PLATE
- WAVE SOLDER CAPABLE TO 265°C PER TE TEST SPEC. 109-202, CONDITION B.

2301844

THIS DRAWING IS A CONTROLLED DOCUMENT.		DWN	AJITH PAI	07FEB2017	9W D SKT W B/L & 4-40 INSERTS 15U" GOLD		2301844-1
DIMENSIONS: mm		CHK	DAN GORENC	07FEB2017	DESCRIPTION		TE PART NO
TOLERANCES UNLESS OTHERWISE SPECIFIED:		APVD		07FEB2017			
0 PLC ± -		PRODUCT SPEC	108-130013				9 WAY D-SUB SOCKET WITH BOARD LOCK
1 PLC ± 0.38		APPLICATION SPEC			SIZE	CAGE CODE	DRAWING NO
2 PLC ± 0.25		WEIGHT	0		A2	00779	C=2301844
3 PLC ± 0.10		CUSTOMER DRAWING			SCALE	SHEET	REV
4 PLC ± -					3:1	1 of 4	H
ANGLES ± 2°							
MATERIAL -							
FINISH -							

THIS DRAWING IS UNPUBLISHED. RELEASED FOR PUBLICATION
 © COPYRIGHT - By - ALL RIGHTS RESERVED.

REVISIONS					
P	LTR	DESCRIPTION	DATE	DWN	APVD
-	-	SEE SHEET 1	-	-	-

PART NUMBER	No. of Contact	A ±0.20	B ±0.20	C ±0.20	D
2301844-2	09	16.34	24.99	30.81	11.08

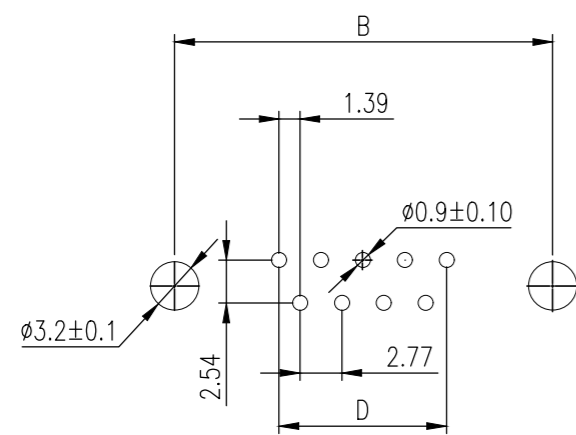
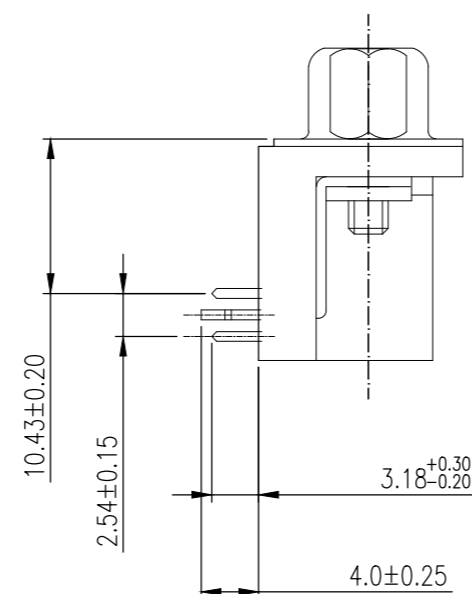
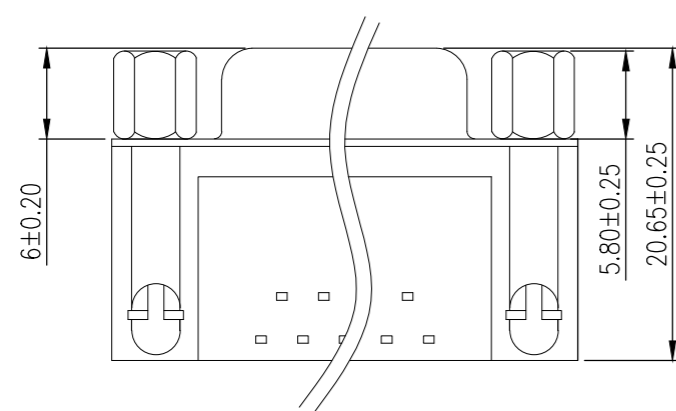
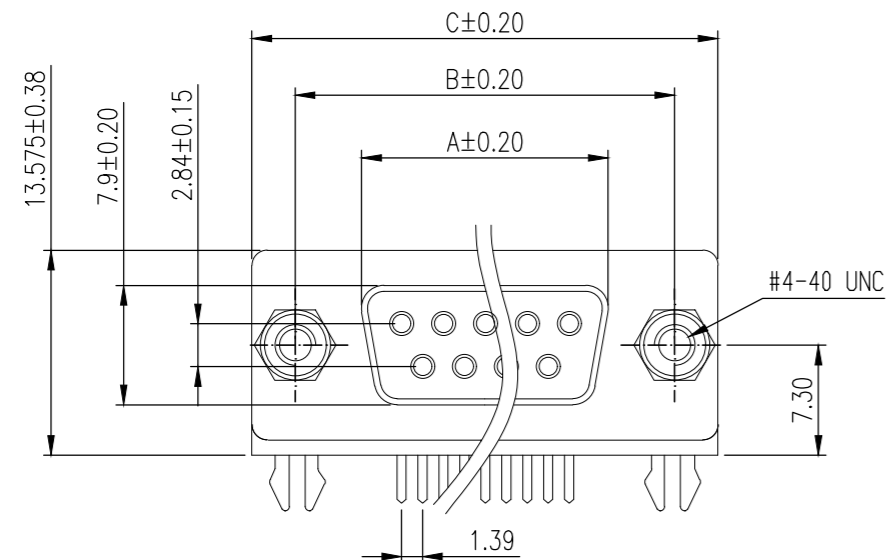

P.C.B LAYOUT

2301844

9W D SKT W B/L & 4-40 S/LOCK 15U" GOLD	2301844-2
DESCRIPTION	TE PART NO



NAME			
9 WAY D-SUB SOCKET WITH BOARD LOCK			
SIZE	CAGE CODE	DRAWING NO	RESTRICTED TO
A2	00779	C=2301844	-
SCALE		SHEET	REV
3:1		2 of 4	H

THIS DRAWING IS A CONTROLLED DOCUMENT.		DWN	07FEB2017
		CHK	07FEB2017
		APVD	07FEB2017
DIMENSIONS: mm		PRODUCT SPEC	108-130013
TOLERANCES UNLESS OTHERWISE SPECIFIED:		APPLICATION SPEC	-
0 PLC	± -	WEIGHT	0
1 PLC	± 0.38	CUSTOMER DRAWING	
2 PLC	± 0.25		
3 PLC	± 0.10		
4 PLC	± -		
ANGLES	± -		
MATERIAL	FINISH		
-	-		

THIS DRAWING IS UNPUBLISHED. RELEASED FOR PUBLICATION
 © COPYRIGHT - By - ALL RIGHTS RESERVED.

REVISIONS					
P	LTR	DESCRIPTION	DATE	DWN	APVD
-	-	SEE SHEET 1	-	-	-

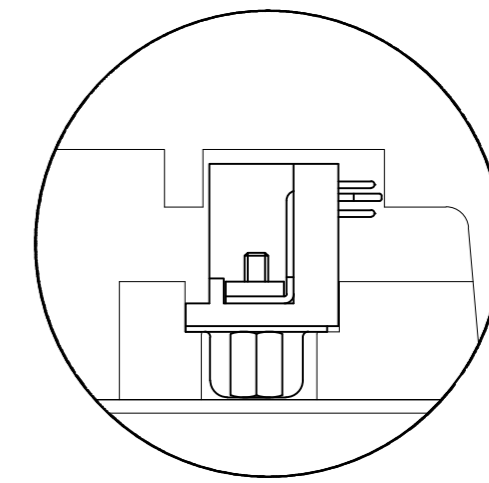
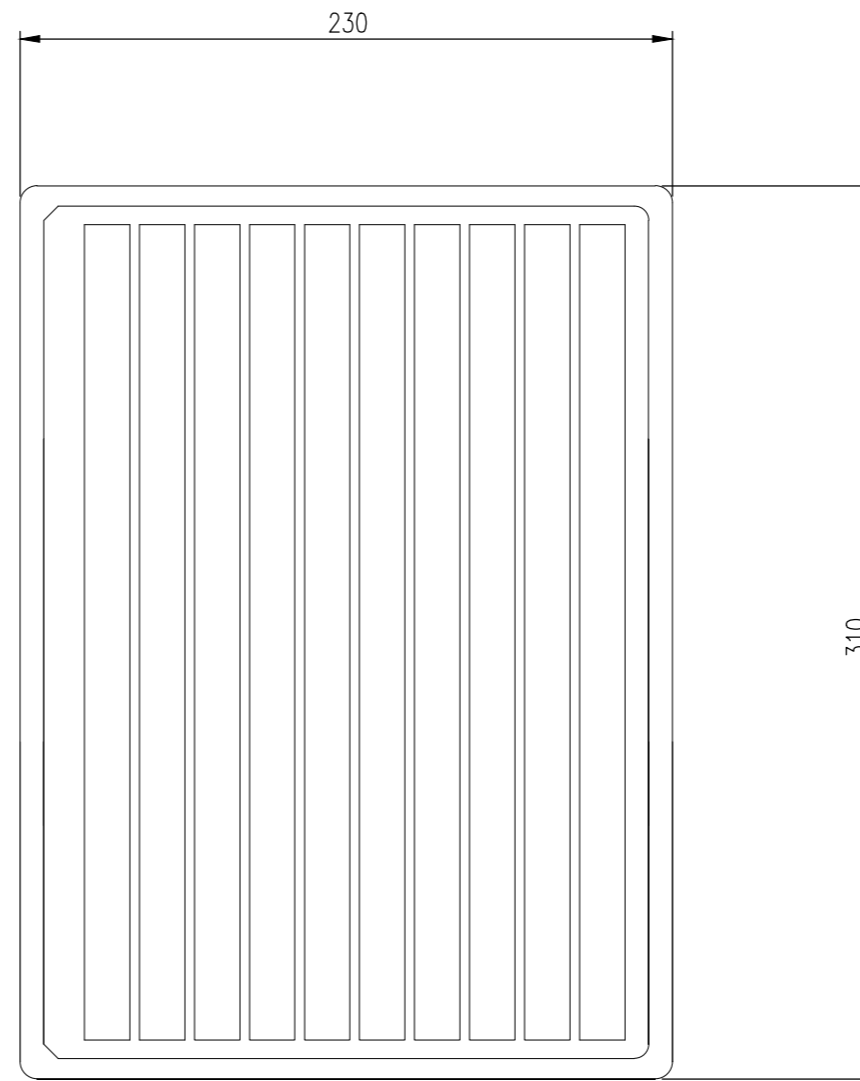
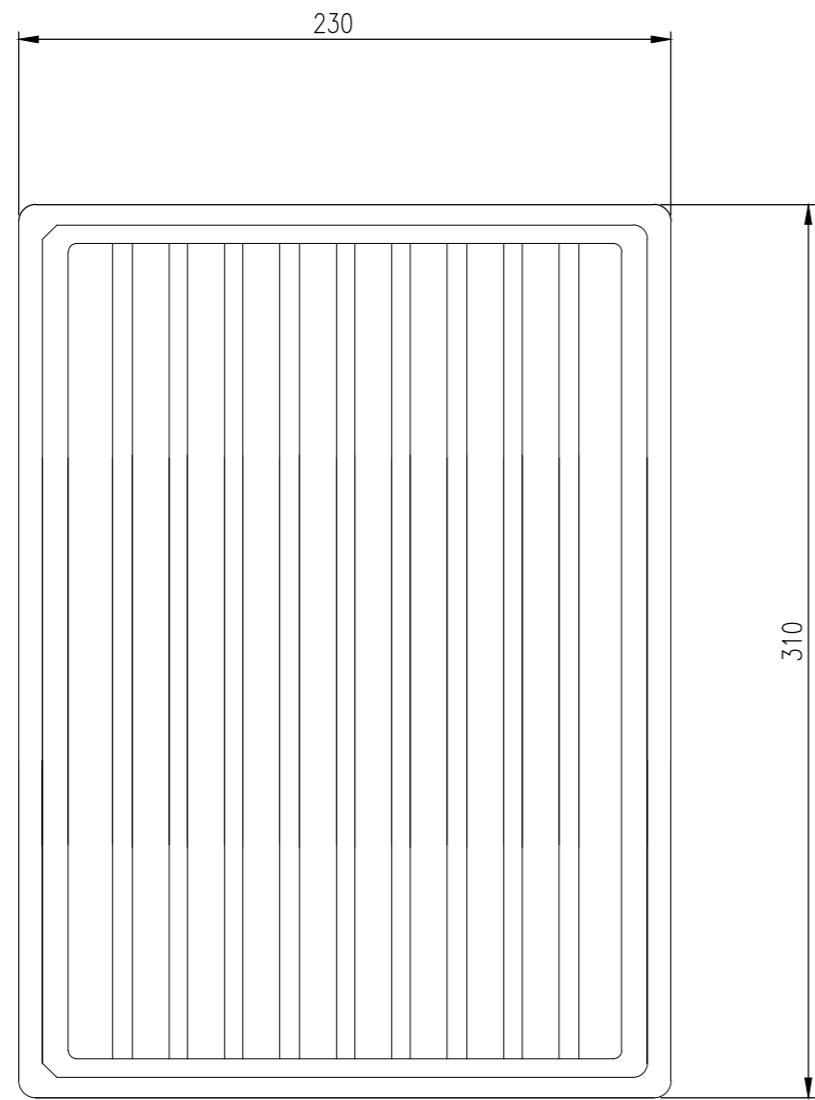
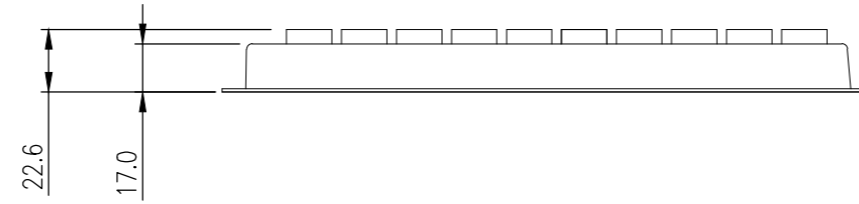
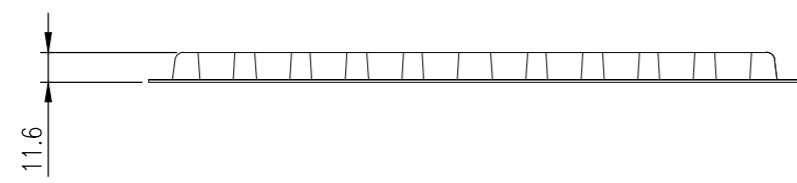

DETAIL A

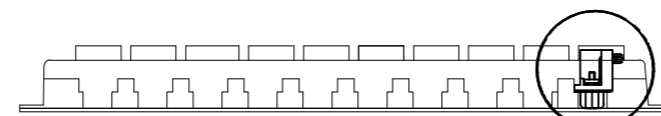

DETAIL A

THIS DRAWING IS A CONTROLLED DOCUMENT.		DWN AJITH PAI 07FEB2017					
DIMENSIONS: mm		CHK DAN GORENC 07FEB2017					
TOLERANCES UNLESS OTHERWISE SPECIFIED:		APVD - 07FEB2017	NAME 9 WAY D-SUB SOCKET WITH BOARD LOCK				
0 PLC ± - 1 PLC ± 0.38 2 PLC ± 0.25 3 PLC ± 0.10 4 PLC ± - ANGLES ± -		PRODUCT SPEC 108-130013	SIZE A2	CAGE CODE 00779	DRAWING NO C=2301844	RESTRICTED TO -	
MATERIAL -		FINISH -	WEIGHT 0	SCALE 3:1		SHEET 3 of 4	REV H
CUSTOMER DRAWING							

THIS DRAWING IS UNPUBLISHED. RELEASED FOR PUBLICATION
 © COPYRIGHT - By - ALL RIGHTS RESERVED.

REVISIONS					
P	LTR	DESCRIPTION	DATE	DWN	APVD
-	-	SEE SHEET 1	-	-	-

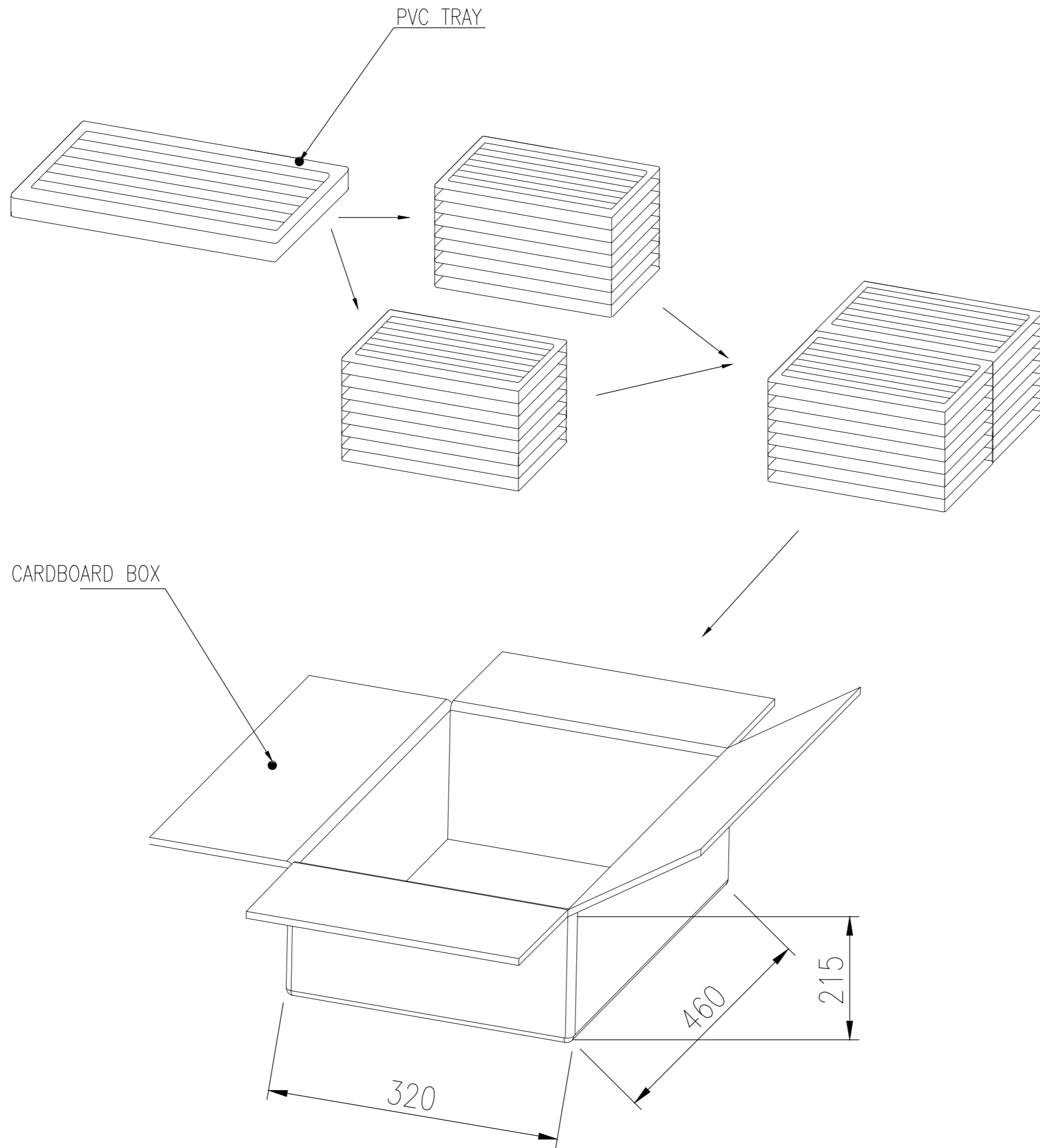

15.672	13.651	90	16	1440	2301844-2
13.080	11.059	90	16	1440	2301844-1
GROSS WEIGHT	NET WEIGHT	PCS/TRAY	TRAYS /CARTON	QUANTITY	PART NUMBER

THIS DRAWING IS A CONTROLLED DOCUMENT.		DWN AJITH PAI 07FEB2017			
DIMENSIONS: mm		CHK DAN GORENC 07FEB2017			
TOLERANCES UNLESS OTHERWISE SPECIFIED:		APVD - 07FEB2017	NAME 9 WAY D-SUB SOCKET WITH BOARD LOCK		
0 PLC ± -		PRODUCT SPEC 108-130013	SIZE A2		
1 PLC ± 0.38		APPLICATION SPEC -	CAGE CODE 00779	DRAWING NO C=2301844	RESTRICTED TO -
2 PLC ± 0.25		WEIGHT 0	SCALE 1:1		
3 PLC ± 0.10		CUSTOMER DRAWING	SHEET 4	OF 4	REV H
4 PLC ± -					
ANGLES ± -					
FINISH -					

2301844

单击下面可查看定价，库存，交付和生命周期等信息

[>>TE Connectivity\(泰科\)](#)