

REVISIONS					
P	LTR	DESCRIPTION	DATE	DWN	APVD
	F2	REVISED PER ECO-12-002084	06FEB12	KH	DR
	F3	REVISED PER ECO-17-014333	11OCT2017	RS	DR

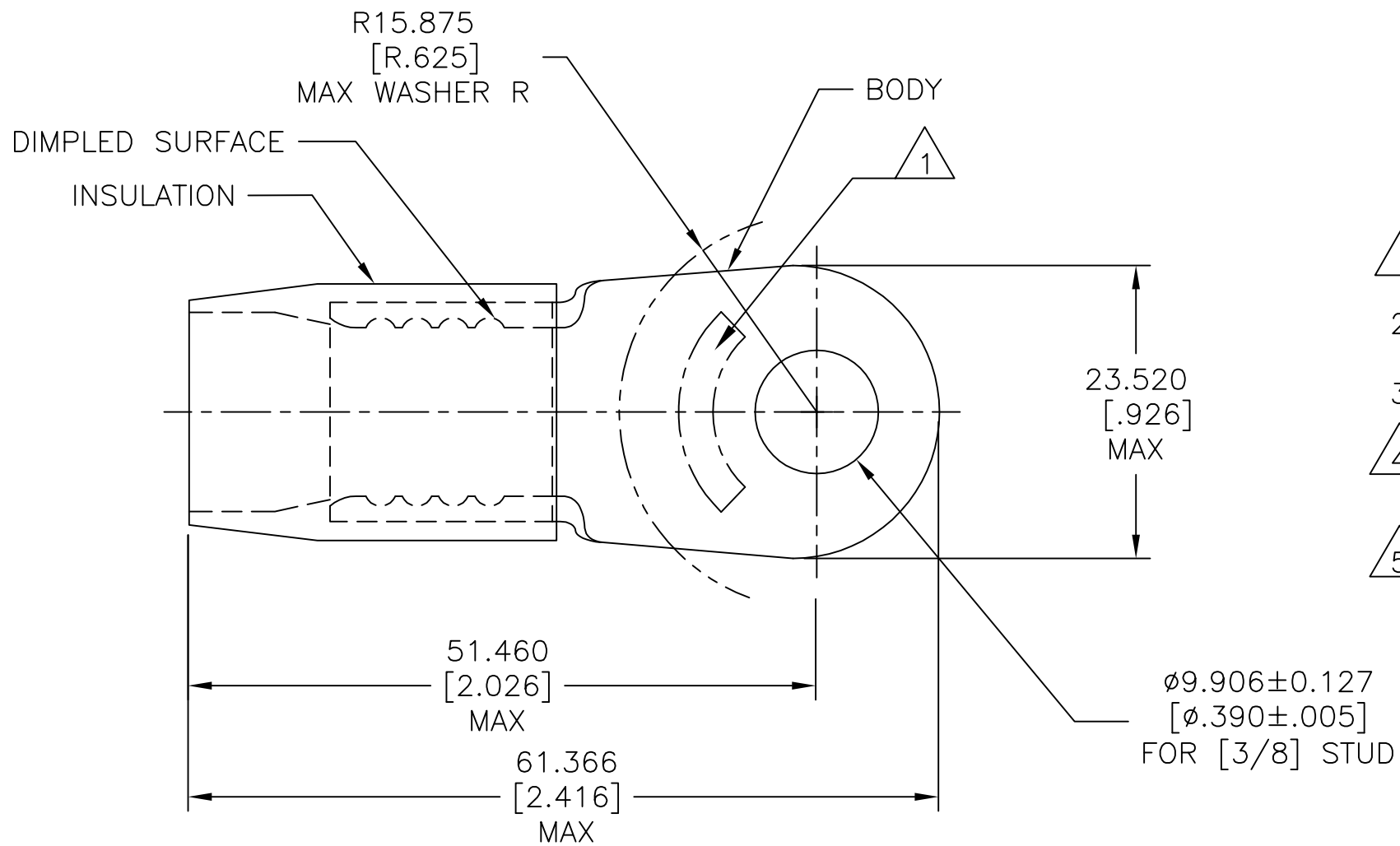

- ① STAMP AMP 2/0 W*, LOCATE APPROX AS SHOWN.
- 2 BODY MATERIAL THK 2.032±0.051 [.080±.002]
- 3 WIRE INSULATION ϕ 15.494 [ϕ .610] MAX.
- ④ BODY: COPPER PER ASTM B-152
INSULATION: NYLON ASTM D4066 TYPE I.
- ⑤ BODY: TIN PLATED PER ASTM B-545
INSULATION: COLOR-YELLOW.

MS25036-136 CLASS 2	50	LOOSE PC	324084
MILITARY P/N AND CLASS	QTY	PACKAGE TYPE	PART NO

MAX RECOMMENDED OPERATING TEMPERATURE: 105°C [221°F]	THIS DRAWING IS A CONTROLLED DOCUMENT.		DWN S.S. GOULDEN 9-28-93	TE Connectivity TERMINAL, RING TONGUE, TERMINYL, WIRE SIZE: 2/0 AWG				
	VOLTAGE RATING: -	DIMENSIONS: mm [INCHES]	TOLERANCES UNLESS OTHERWISE SPECIFIED:					CHK R. HERSEY 9-28-93
CIRCULAR MIL AREA: 60.6-76.3mm ² [119,500-150,500] STRANDED		0 PLC ± - 1 PLC ± - 2 PLC ± - 3 PLC ± 0.127[.005] 4 PLC ± - ANGLES ± -	PRODUCT SPEC SAE AS7928	APPLICATION SPEC	SIZE	CAGE CODE	DRAWING NO	RESTRICTED TO
	MATERIAL ④	FINISH ⑤	WEIGHT -	-	A3	00779	C=324084	-
			CUSTOMER DRAWING	SCALE NTS	SHEET 1 OF 1	REV F3		

单击下面可查看定价，库存，交付和生命周期等信息

[>>TE Connectivity\(泰科\)](#)